

Feel at Home

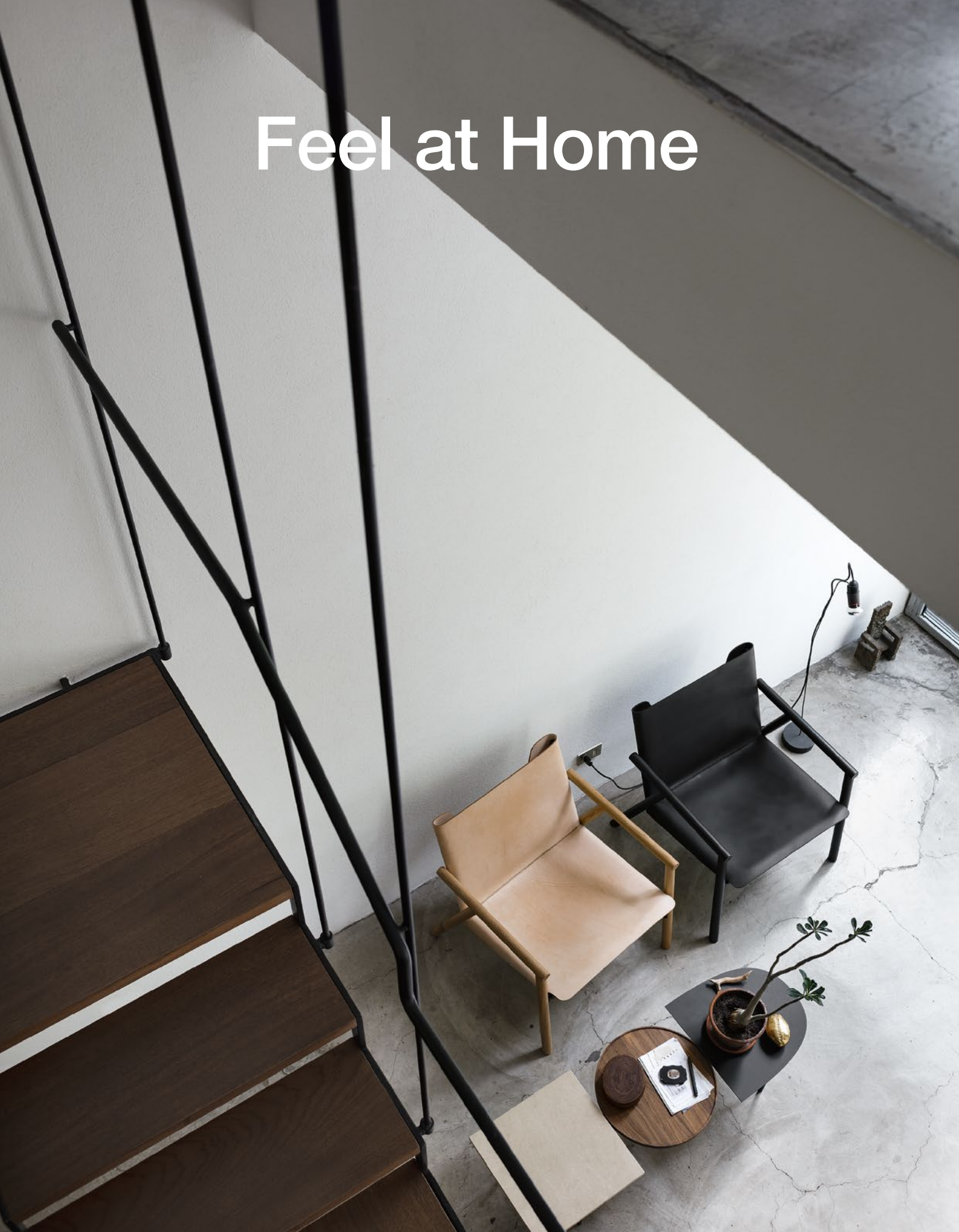

A—Z index	2	Seating	10	Made in Italy	293
Visual index	3	Tables—low tables	136	History	295
		Accessories	242	New HQ	296
Colouring pictures	A	Rugs	280	The Club	299
				Eco—friendliness	300
				Designers	304
				Compasso d’Oro Award	306
				Finishes	310

A—Z index

1085 Edition	58	Face	124	Plana	104
BCN	128	Font	226	Poule	200
BCN table	210	Hang—Up	268	Pulp	114
be—Easy	182	Holo	136	Rama	82
Blio	242	Joko	72	Rotor	236
Boiacca	170	Lips	274	Sharky	38
Brioni	22	LP	78	Sofa cushions	278
Box /BoxOne	260	Maki	164	Sushi	152
Bureau	272	Mem	110	Tenso Sofa System	10
Colander	90	Mustache—GA	284	Thin—K	144
Compas	98	Mustache—RE	288	TNP	206
Constellations	216	Mustache—SA	290	Tuile	30
CU	232	Neat	178		
Degree	222	Nori	158		
Dot Shelving System	250	Oops /Oops IDIA	186		
Dua	66	Pikaia	118		
Elephant	46				
Elephant table	194				
Extra Large	266				

Sofas



Brioni
22



Tenso Sofa System
10



Tuile
30



Sofa cushions (optional)
278

Seating



1085 Edition
58



Colander
90

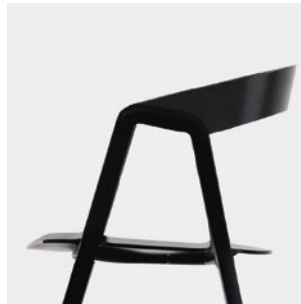

Compas
98



Dua
66

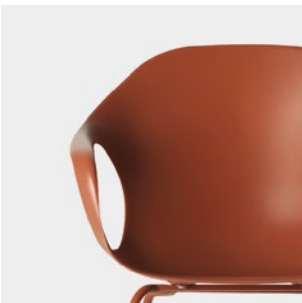

Elephant
46



Face
124



Joko
72



LP
78



Mem
110



Pikaia
118



Plana
104



Pulp
114



Rama
82



Sharky
38



Lips (optional)
274

Stools



BCN
128



Colander
90



Joko
72



Rama
82

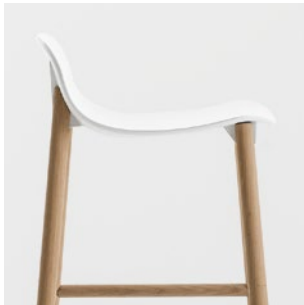

Sharky
38



Lips (optional)
274

Tables



BCN table
210



be-Easy
182



Boiaccia
170



Elephant table
194



Holo
136



Maki
164



Neat
178

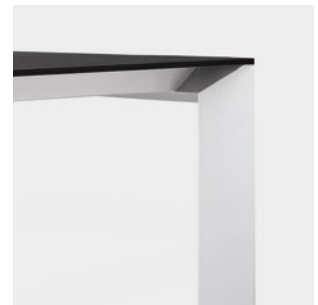

Nori
158



Oops/Oops IDIA
186



Poule
200



Sushi
152



Thin-K
144



TNP
206

Low tables



BCN table
210



Constellations
216



CU
232



Degree
222



Elephant table
194



Font
226



Holo
136



Rotor
236

Accessories



Blio
242



Box /BoxOne
260



Bureau
272



Dot Shelving System
250



Extra Large
266



Hang-Up
268



Lips
274

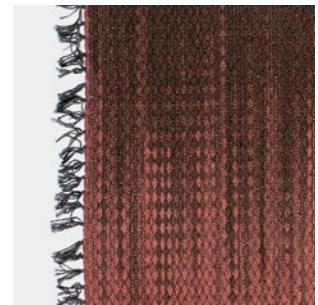

Mustache-GA
284



Mustache-RE
288

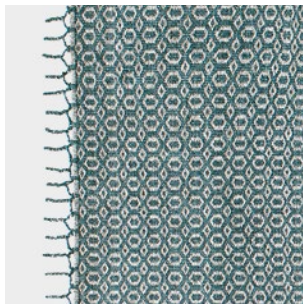

Mustache-SA
290



Sofa cushions
278

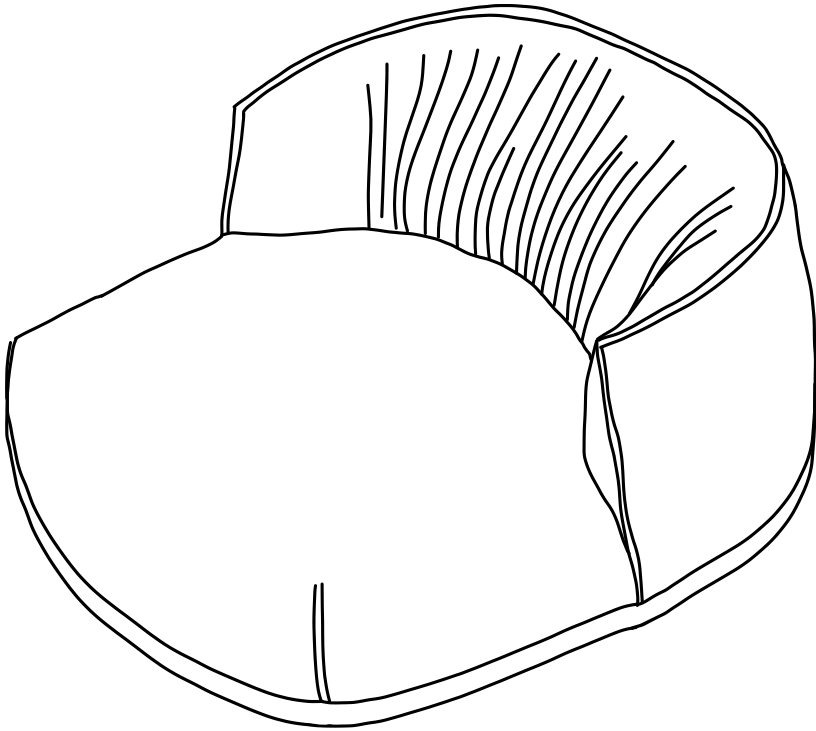

A



Font

In typography and computer science, fonts are a set of specific signs that share a certain graphic style or are intended to perform a given function. The Font coffee table is all this: a mobile table designed for both indoor and outdoor use, featuring a unique graphic style.

Font was created thanks to a new partnership with the Swedish design studio Claesson Koivisto Rune. For Kristalia, three architects developed a coffee table with an organic shape, designed and developed in many different materials, thus experimenting with them to achieve a unique shape.

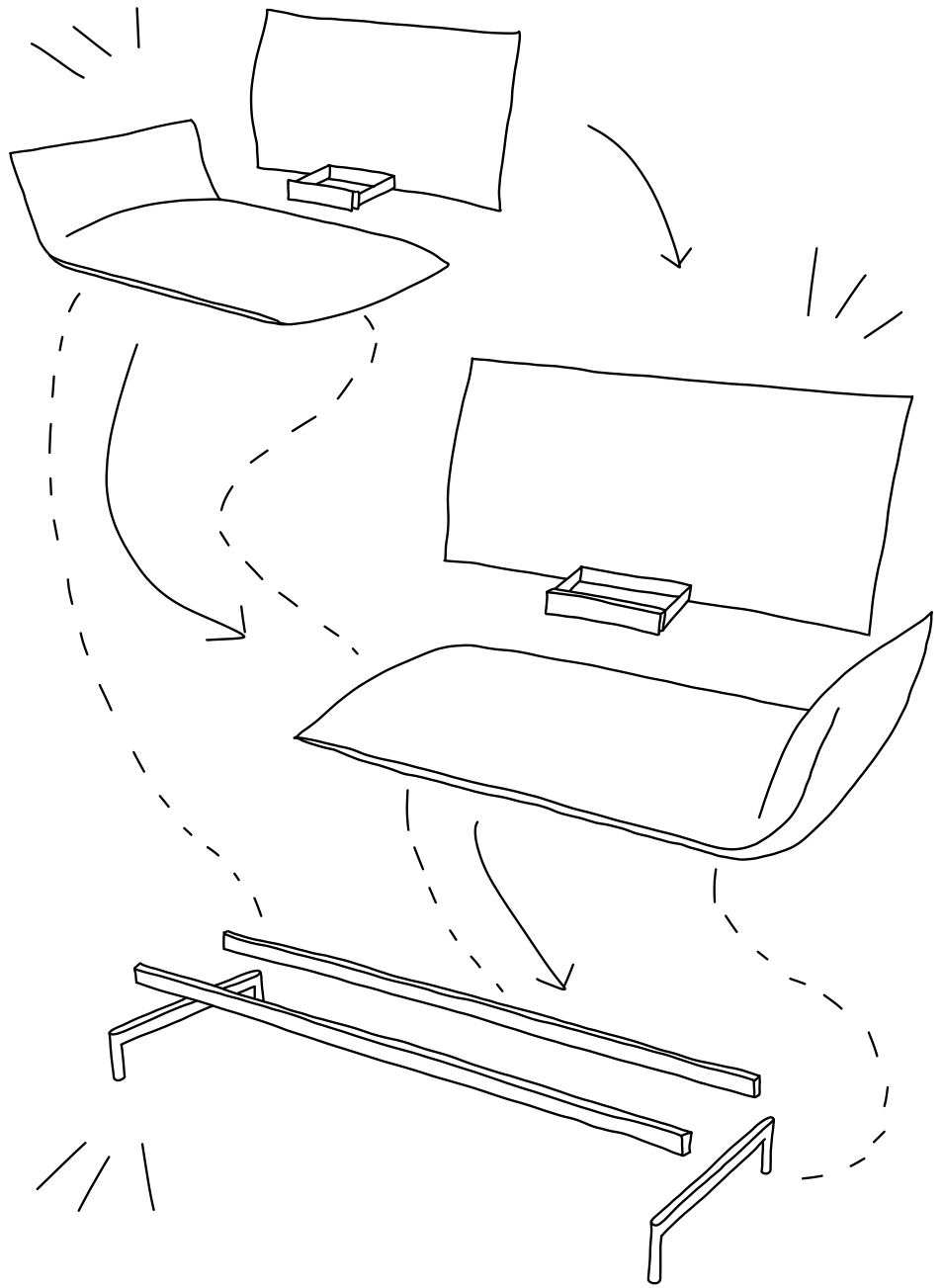

D

LUCA NICHETTO

In 2005, Luca Nichetto designed his very first chair, Face, which is still in Kristalia's collection. Now in 2018, Luca has designed the first real sofa for Kristalia called Tenso. It gets its name from tensile structures, which have inspired the dynamic, light and "tensioned" shapes of the sofa.

Its special feature is the inner tension between its components, which keeps them firmly suspended and open, just like a welcoming embrace. Its sleek lines and tailored details highlight the softness of its fabric or leather upholstery. Its modular tubular frame adapts to various seat dimensions, whereas the backrest provides extra comfort with the addition of a headrest with adjustable tilting. Optional soft cushions and a variety of support surfaces, which can be combined with the frame, allow Tenso to easily adapt to residential or contract furniture environments.

TENSO SOFA SYSTEM p. 10

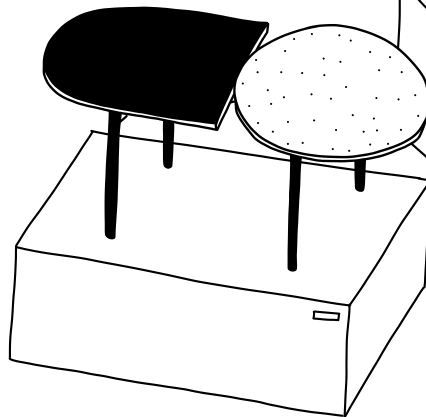
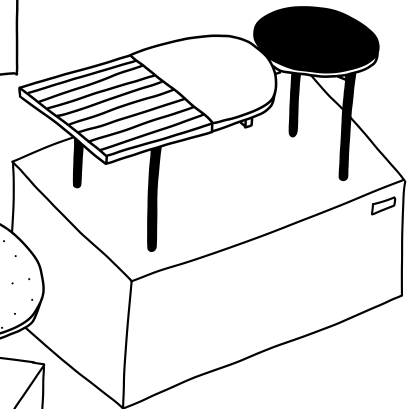
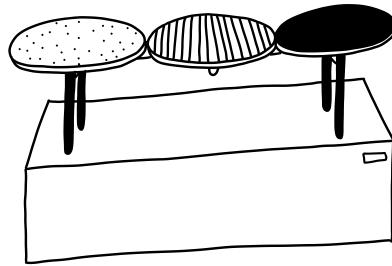
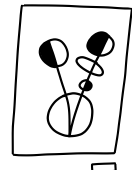
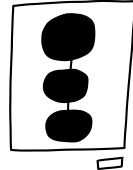
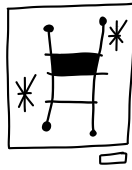

LUCA NICHETTO

Joan Mirò and Alexander Calder, who met in Paris in 1928, belonged to the Montparnasse art scene.

The design of the Constellations coffee table by Luca Nichetto is a tribute to that professional and intimate meeting.

The coffee table features the juxtaposition of shapes and materials; squares, semi-ellipses and circles can be freely combined to create compositions of surfaces in various thicknesses and textures.

Available in a variety of colours and materials, tops are supported by a metal frame in different sizes, which is so discreet that it seems to be invisible, providing the effect of levitating objects, like a constellation.

CONSTELLATIONS p. 216

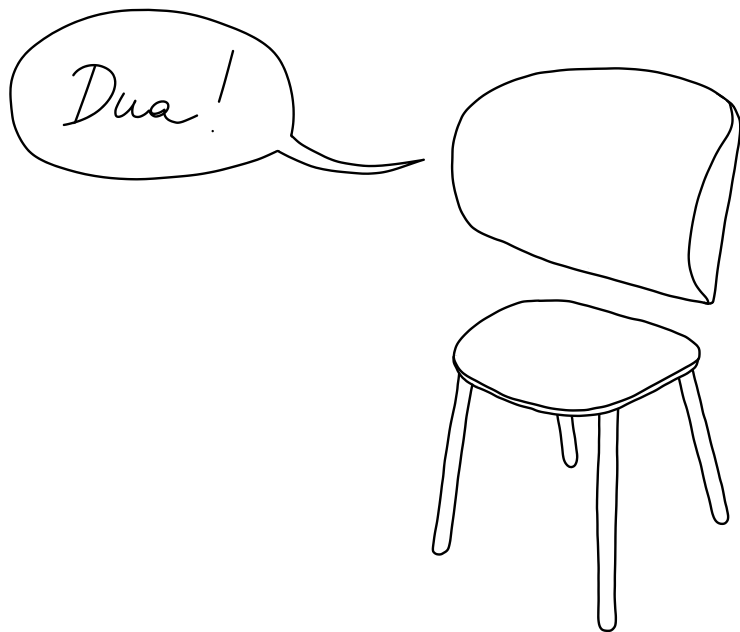
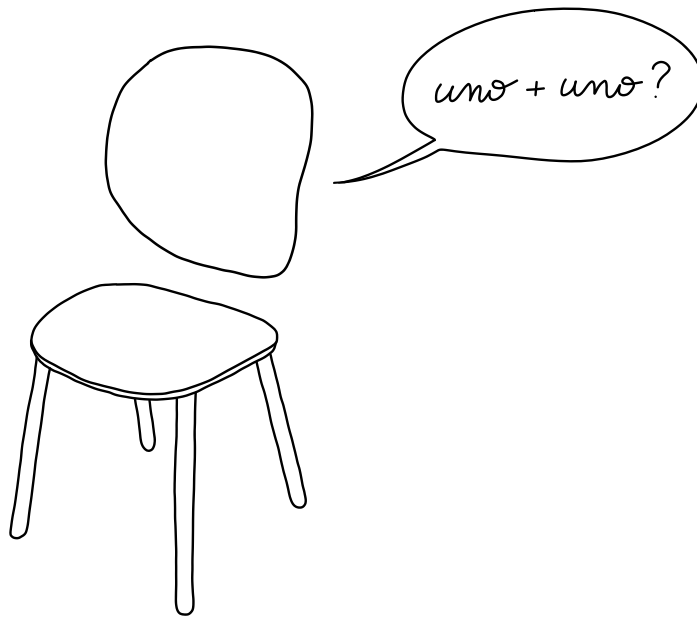

Läufer & Keichel have become part of the Kristalia team of designers.

Let's return to the theme of Reductionism, where simplicity, functionality and emotional connection are ideally expressed in the Dua project. "Dua" is the Indonesian name for number two. Two chairs developed with or without armrests. Two designers immediately tuned in with Kristalia's development methods, where the combination of technological research and attention to detail are at the forefront.

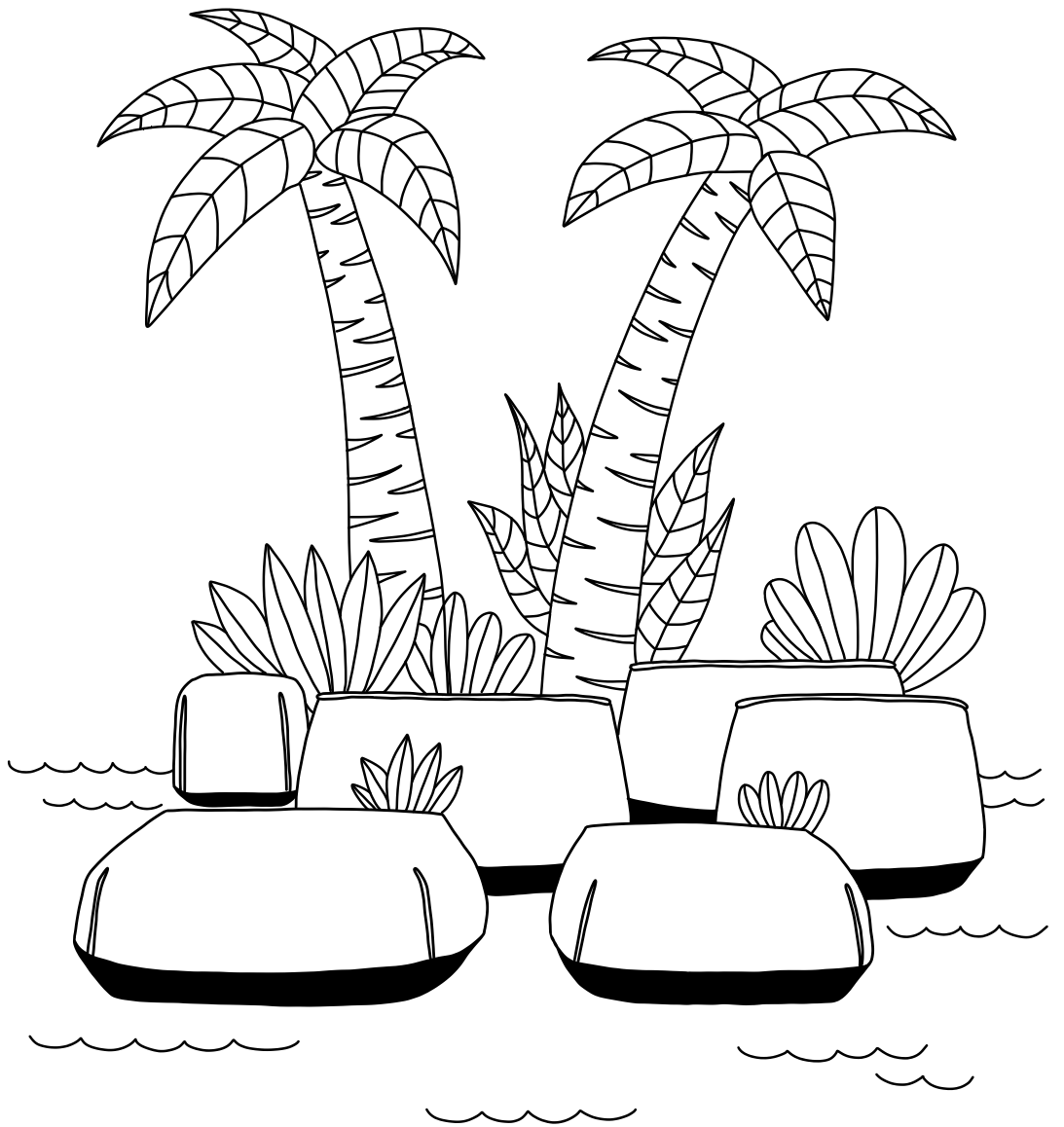

LUCIDIPEVERE

The Brioni islands form a small archipelago in the Adriatic Sea. LucidiPevere have created a collection of poufs, lounge chairs and daybeds based on this concept.

Light and easy to move, they can be used to create a multitude of outdoor compositions, experimenting with different shapes, colours and sizes.

The frame is made of stiff polyurethane with differentiated-density polyurethane padding and plastic straps.

After the success of the outdoor versions, the designers have developed an indoor version with the characteristic dark band on the lower part covered with the same fabric as the seat.

Today the poolside pouf has become a "sofa-side" pouf.

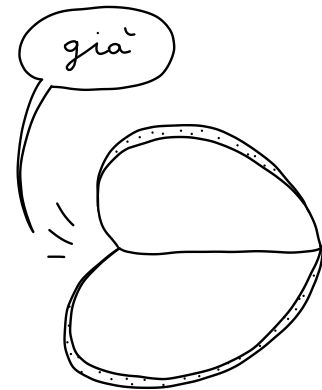
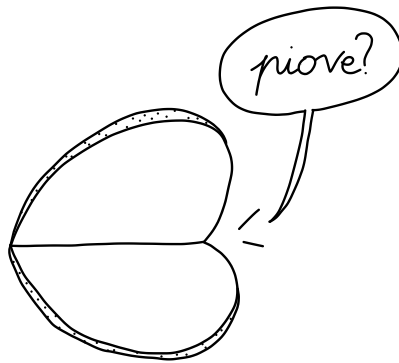
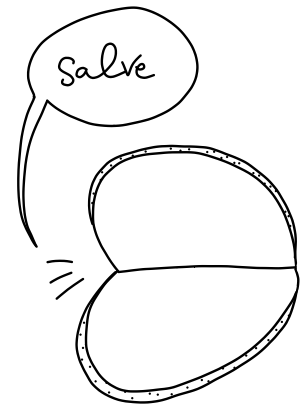

LUCIDIPEVERE

Lips cushions have been designed to make our chairs even more comfortable. Designed by LucidiPevere, they come in three different shapes – round, shaped and rectangular, the latter specifically designed for the Mem chair – to adapt to all chairs, from the smallest to the largest. Countless options are available for upholstery, whereas a wide variety of colours allows you to match the colours with chairs as you please. Lips cushions feature a black trim and a central seam, which makes the round version look like a mouth. The lower surface is covered with non-slip material, a technical detail that makes them even more comfortable.

LIPS p. 274

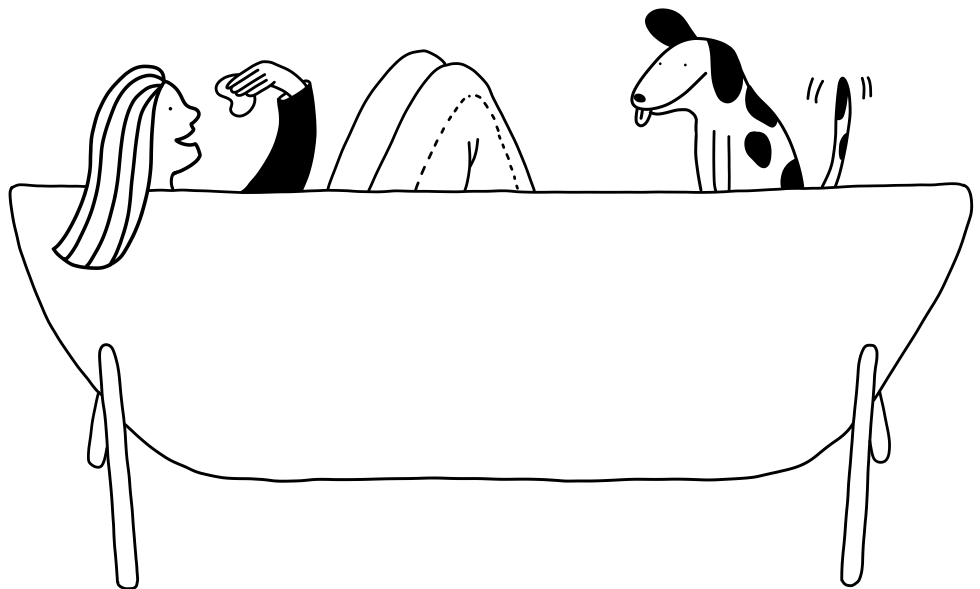
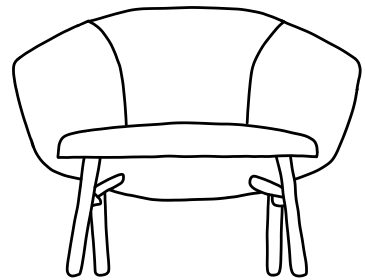

PATRICK NORGUET

A "tuile" is a thin biscuit of French origin that gets its name from the typical French roof tile.

We like to imagine that the designer Patrick Norguet, also French, got his inspiration for Tuile at breakfast time or when gazing at the rooftops from the window of his studio.

The shape of the backrest and armrests of Tuile padded items is embracing, just like the biscuit of the same name.

The frame is made of sturdy metal with anti-corrosion treatment and a powder coating. Thanks to its special fabric it can be used both indoors and outdoors. It has also been designed for contract furniture projects in offices, waiting rooms and hotels.

TUILE p. 30

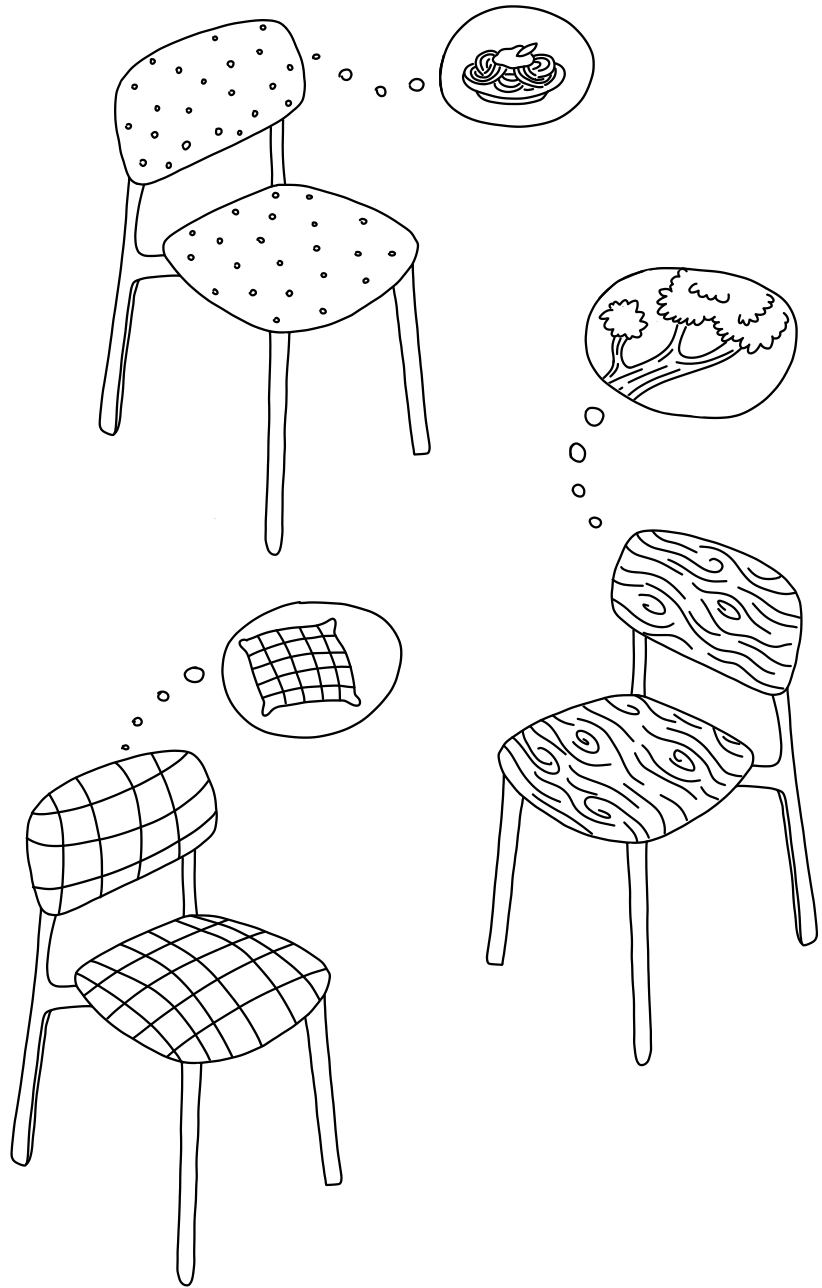

PATRICK NORGUET

One of Kristalia's hallmarks is to give successful products new life. The Colander chair and stool, designed by Patrick Norguet, were made for outdoor use. They have a seat and backrest made of injection-moulded polypropylene featuring a perforated texture reminiscent of a colander (as the name suggests).

Last year, it was presented with a wood seat and backrest, whereas this year it is being presented with fabric upholstery. The frame, which remains the same, is light and unalterable and made of painted aluminium. Now the three different versions can be perfectly matched to create versatile and coordinated spaces.

COLANDER PADDED p. 90

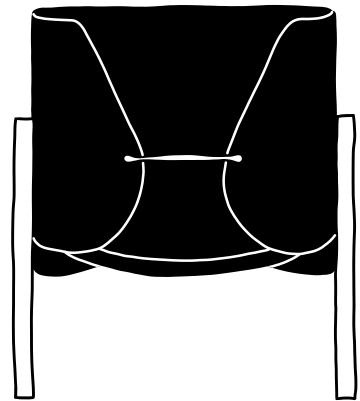
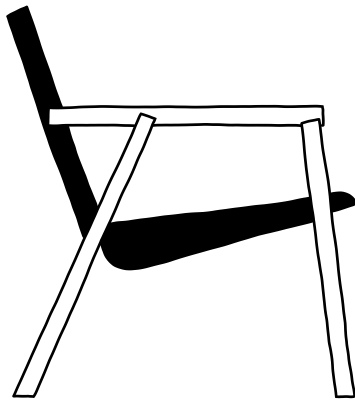
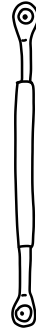
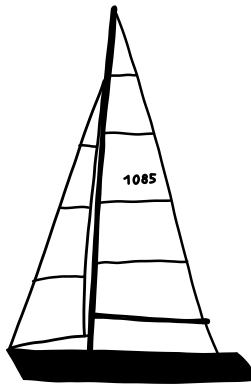
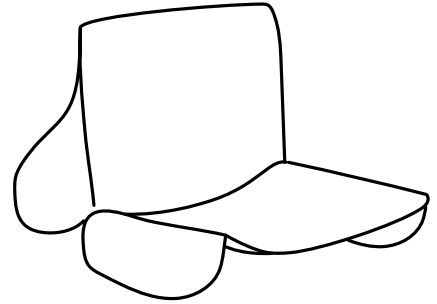
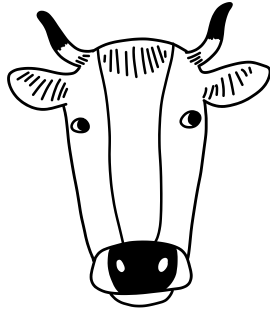

Kristalia believes in the culture of transforming objects over time (such as hide or cement) to improve their quality and also believes in the value of industrial items, which thanks to wear, the seasons and hands (of those who made them but also of those who used them), can become unique pieces.

The 1085 Edition chair, designed by Bartoli Design, was created to develop an original and unparalleled project in terms of quality and aesthetic appeal.

This year, presented in a lounge version, the chair has a larger and lower seat, with the same characteristics as its forerunner. Its designers wanted to face the challenge of developing it to the next level.

Moreover, a total black version will be available to offer additional elegance.

3

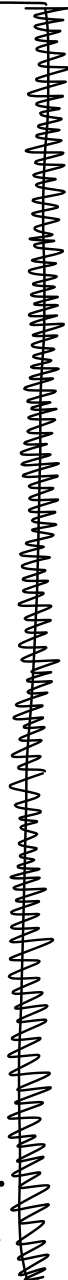
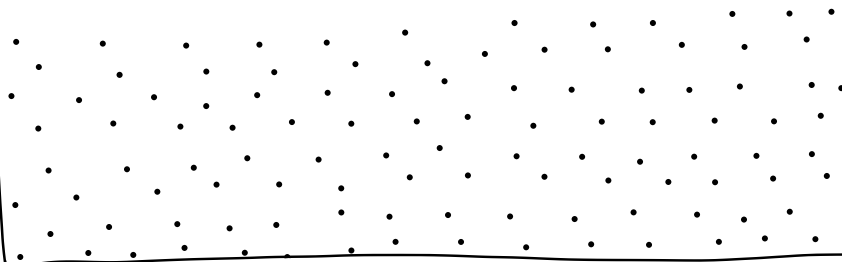
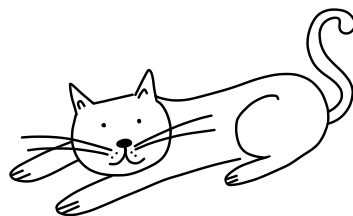

1085 Edition	58	Rama	82
BCN	128	Sharky	38
Brioni	22	Tenso Sofa System	10
Colander	90	Tuile	30
Compas	98		
Dua	66		
Elephant	46		
Face	124		
Joko	72		
LP	78		
Mem	110		
Pikaia	118		
Plana	104		
Pulp	114		



Tenso Sofa System







Tenso sofa
Upholstered Curmi fabric



Tenso sofa
Upholstered Steelcut Trio 3 and Hero fabrics

Constellations occasional table
H. 31 cm

Mustache – GA rug
GA-02 terracotta brown



Font occasional table
Cement



Tenso sofa
Upholstered Steelcut Trio 3 and Hero fabrics

Font occasional table
Cement



Tenso sofa
Upholstered Curmi fabric

Constellations occasional table
H. 41 cm



Tenso sofa
Upholstered Curmi fabric

Brioni small lounge chair
Upholstered Hero fabric

Constellations occasional table
H. 31-41 cm



Brioni medium pouf
Upholstered Cummi fabric

Mustache—GA rug
GA-03 green



1



2



3



4



5

Elements

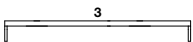
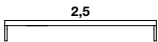
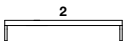

Frame
L 85-121-158-194 P 68 H 21 cm
W 33¹/₈"-47⁵/₈"-62²/₈"-76³/₈" D 26⁶/₈" H 8²/₈"

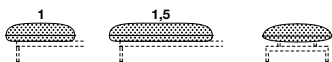

Seat
L 73-110 P 73 H 39 cm
W 28⁶/₈"-43²/₈" D 28⁶/₈" H 15³/₈"

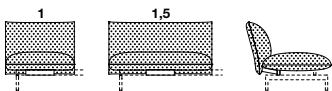

Seat + backrest
L 73-110 P 85 H 73 cm
W 28⁶/₈"-43²/₈" D 33⁴/₈" H 28⁶/₈"

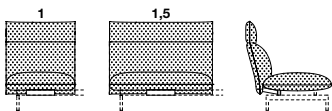

Seat + backrest with headrest
L 73-110 P 89 H 99 cm
W 28⁶/₈"-43²/₈" D 35" H 39"

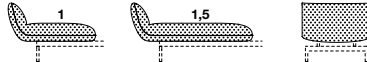

Seat with armrest (Rh/Lh)
L 92-129 P 73 H 65 cm
W 36²/₈"-50⁰/₈" D 28⁶/₈" H 25⁵/₈"

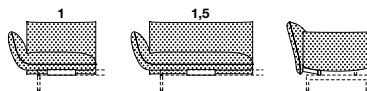

Seat with armrest + backrest (Rh/Lh)
L 92-129 P 85 H 73 cm
W 36²/₈"-50⁰/₈" D 33⁴/₈" H 28⁶/₈"

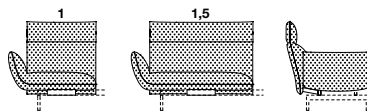

Seat with armrest + backrest with headrest (Rh/Lh)
L 92-129 P 89 H 99 cm
W 36²/₈"-50⁰/₈" D 35" H 39"

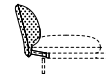

Side backrest
L +12 P 73 H 73 cm
W +4⁶/₈" D 28⁶/₈" H 28⁶/₈"

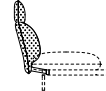

Side backrest with headrest
L +16 P 73 H 99 cm
W +6²/₈" D 28⁶/₈" H 39"



Occasional tabletop
L 36,5-73 P 73 H 30 cm
W 14³/₈"-28⁶/₈" D 28⁶/₈" H 11⁶/₈"

Tenso Sofa System

DESIGN BY LUCA NICHETTO, 2018

▣ Disegnato da Luca Nichetto, Tenso è un sistema composto di elementi imbottiti ispirato alle tensostrutture. Il fulcro del sistema è il telaio, una struttura tubolare leggera e solida su cui vengono fissati i vari elementi – sedili, schienali, cuscini e piani tavolo tra cui si viene creare una tensione che mantiene le varie parti sospese e aperte, come un abbraccio accogliente. Gli elementi imbottiti, da combinare a piacere per creare divani, divani con penisola o pouf, anche con piani tavolo incorporati, sono morbidi e confortevoli, mentre il rivestimento in tessuto o pelle è caratterizzato da dettagli sartoriali. L'elemento con poggiatesta reclinabile offre ancora più comfort a chi ama leggere o guardare la tv.

EN **Designed by Luca Nichetto, Tenso is a system comprising padded items inspired by tensile structures. The core of the system is its frame, a light and sturdy tubular structure to which the various elements are fixed – seats, backrests, cushions and tabletops, between which a tension is created that keeps the various parts suspended and open, like a welcoming embrace. The padded items, which can be combined as required to create sofas, sofas with a peninsula element or a pouf, also with built-in tabletops, are soft and comfortable, whereas the upholstery in fabric or leather features tailored details. The element with a reclining headrest offers extra comfort to those who love reading or watching TV.**

DE Tenso ist ein von Luca Nichetto entworfenes System von Polster-elementen, die sich von Flächentragwerken inspirieren ließen. Das Kernstück des Systems ist der Rahmen, eine leichte und starke Rohrstruktur, an der die verschiedenen Elemente - Sitzflächen, Rückenlehnen, Kissen und Tischplatten - befestigt sind. Unter diesen Elementen entsteht eine Spannung, die die einzelnen Teile wie eine einladende Umarmung schwebend und offen hält. Die weichen und komfortablen Polster-elemente lassen sich ganz nach Belieben kombinieren, um Sofas, Sofas mit Chaiselongue oder Poufs, auch mit eingefügten Tischplatten, zusammenzustellen, die Bezüge aus Stoff oder Leder zeichnen sich durch Details der besten Schneiderkunst aus. Das Element mit neigbarer Kopfstütze bietet noch mehr Komfort beim Lesen oder Fernsehen.

ES Diseñado por Luca Nichetto, Tenso es un sistema de asientos que se inspira en las tensoestructuras. El eje central del sistema es el bastidor, una estructura tubular ligera y sólida en la que se fijan los distintos elementos: asientos, respaldos, cojines y sobres de mesa entre los que se crea una tensión que mantiene las distintas partes suspendidas y abiertas, como en un cálido abrazo. Suaves y confortables, los asientos pueden combinarse a voluntad para crear sofás, sofás con península o pufs, incluso con sobres de mesa incorporados, mientras que el revestimiento de tejido o de piel se caracteriza por sus detalles sartoriales. El elemento con

reposacabezas reclinable ofrece un confort adicional para los amantes de la lectura y la televisión.

FR Dessiné par Luca Nichetto, Tenso est un système d'éléments garnis s'inspirant des structures à câbles. Le cœur du système, c'est une structure tubulaire, légère et solide, à laquelle sont fixés les assises, les dossiers, les coussins et les plateaux de table entre lesquels se crée une tension qui maintient les différentes parties suspendues et ouvertes. Les éléments garnis, moelleux et confortables, se composent selon les besoins pour créer des canapés simples, avec chaise longue, avec pouf et avec plateaux de table incorporés alors que le revêtement en tissu ou en cuir se distingue par des détails artisanaux. L'élément avec repose-tête inclinable est parfait pour lire ou regarder confortablement la TV.

Steel legs



Steel beams



Fenix-NTM® black edge top



Fenix-NTM® coloured edge top



Stone top



Divina Melange 2 (Kvadrat®) fabric



Divina MD (Kvadrat®) fabric



Hero (Kvadrat®) fabric

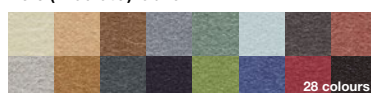

Steelcut Trio 3 (Kvadrat®) fabric



Curmi (Torri Lana®) fabric

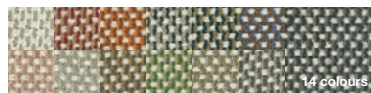

Regal (Erimiti®) velvet fabric

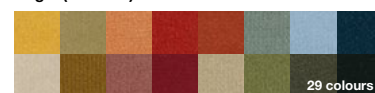

Extrema AU (Flukso®) synthetic leather



Coast (Elmo®) pigmented & printed leather

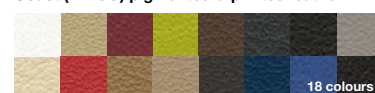

Elmosoft (Elmo®) semi-aniline leather

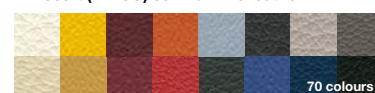

Elmotique (Elmo®) aniline leather

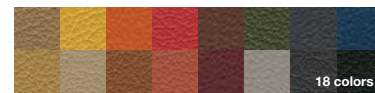



Brioni small lounge chair
Upholstered Hero fabric

Brioni medium pouf
Upholstered Cummi fabric

Font occasional table
Cristalplant®

Mustache—SA rug
SA-01 green

Brioni







Brioni small lounge chair
Upholstered Elmosoft leather



Brioni large lounge chair
Upholstered Regal velvet fabric

Brioni medium pouf
Upholstered Curmi fabric



Brioni small pouf
Upholstered Steelcut Trio 3 fabric



Type

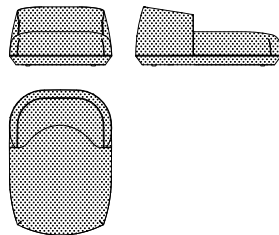
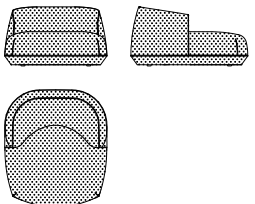
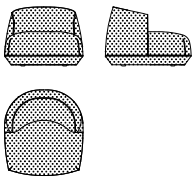

Lounge armchair small
L 84 P 92 H 62 cm
W 33 1/8" D 36 2/8" H 24 3/8"

Lounge armchair large
L 109 P 124 H 62 cm
W 42 7/8" D 48 7/8" H 24 3/8"

Daybed
L 109 P 154 H 62 cm
W 42 7/8" D 60 5/8" H 24 3/8"

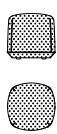
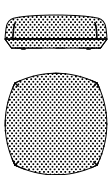
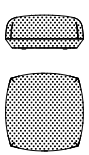

Pouf medium
L 83 P 83 H 36 cm
W 32 5/8" D 32 5/8" H 14 1/8"

Pouf large
L 108 P 108 H 36 cm
W 42 4/8" D 42 4/8" H 14 1/8"

Pouf small
L 51 P 51 H 46 cm
W 20 1/8" D 20 1/8" H 18 1/8"

Brioni

DESIGN BY LUCIDIPEVERE, 2018

▣ Ispirata all'omonimo arcipelago del mare Adriatico, Brioni è una collezione di sedute composta da poltrone lounge, daybed e pouf dall'aspetto morbido e pieno. Pensati inizialmente per l'outdoor, i sei elementi di Brioni sono stati ridisegnati da LucidiPevere per l'uso domestico: l'intera superficie della seduta è ora rivestita in tessuto o pelle, senza la fascia inferiore scura che evitava il contatto con il terreno. Della versione precedente rimane la cerniera, dettaglio estetico e funzionale, così come l'imbottitura soffice in poliester con doghe in plastica. Leggeri e facili da spostare, i pouf sono ideali accanto al divano, mentre poltrone e daybed sono sedute comode e versatili che invitano al relax.

EN **Inspired by the archipelago in the Adriatic Sea of the same name, Brioni is a collection of seats comprising lounge armchairs, daybeds and poufs with a soft and full appearance. Initially designed for outdoor use, the six items in the Brioni collection have been redesigned by LucidiPevere for use in homes: the entire surface of the seat is now covered in fabric or leather, without the dark lower band that prevented contact with the ground. It has a zip, an aesthetic and functional detail, like the previous version, as well as soft polyester padding with plastic slats. Light and easy to move, the poufs are perfect when positioned next to the sofa, whereas the armchairs and daybeds are comfortable and versatile seats that invite you to relax.**

Divina Melange 2 (Kvadrat®) fabric



Divina MD (Kvadrat®) fabric

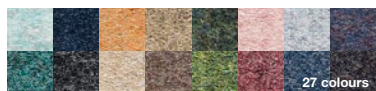

Hero (Kvadrat®) fabric

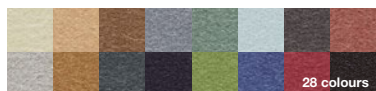

Steelcut Trio 3 (Kvadrat®) fabric

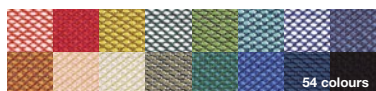

Field 2 (Kvadrat®) fabric



DE **Inspiriert vom gleichnamigen Archipel im adriatischen Meer präsentiert sich die Sitzmöbelkollektion Brioni mit Lounge-Stühlen, Daybeds und Poufs mit weicher und voller Optik. Die ursprünglich für den Außenbereich konzipierten sechs Elemente von Brioni wurden von LucidiPevere für den häuslichen Bereich neu überarbeitet: Die gesamte Oberfläche des Sitzmöbels ist jetzt mit Stoff oder Leder bezogen und hat keinen unteren dunklen Streifen mehr, der den Kontakt des helleren Materials mit dem Boden verhinderte. Von der einstigen Version bleiben der Zippverschluss, ein ästhetisches und funktionelles Detail, und die weiche Polsterung aus Polyester mit Leisten aus Kunststoff. Die leichten und mühelos zu verschiebenden Poufs passen perfekt neben das Sofa, die Sessel und Daybeds sind hingegen bequeme und vielseitige Sitzmöbel, die zum Entspannen einladen.**

ES **Inspirada en el archipiélago homónimo del mar Adriático, Brioni es una colección de asientos compuesta por butacas lounge, divanes y pufs de aspecto suave y compacto. Pensados inicialmente para ambientes exteriores, los seis elementos de Brioni han sido rediseñados por LucidiPevere para el uso doméstico: toda la superficie del asiento está ahora revestida con tejido o piel, sin la banda inferior oscura que evitaba el contacto con el suelo. De la versión anterior se conserva la cremallera, un detalle estético y funcional, así como el suave relleno de poliéster con listones de plástico. Ligeros y fáciles de desplazar, los pufs son ideales junto al**

sofá, mientras que las butacas y los divanes son asientos cómodos y versátiles que invitan al relax.

FR **S'inspirant de l'archipel de l'Adriatique du même nom, Brioni est une collection de poufs et de fauteuils relaxation et Daybed compacts et moelleux. Pensés au départ pour l'extérieur, les six éléments Brioni ont été redessinés par LucidiPevere pour l'intérieur: ils sont désormais entièrement revêtus en tissu ou en cuir, sans la bande foncée dans le bas qui évitait le contact avec le sol. De la version précédente, il ne reste que la fermeture éclair à la fois esthétique et fonctionnelle et le garnissage en polyester avec lattes en plastique. Légers et simples à déplacer, les poufs sont idéaux près du canapé alors que les fauteuils et les Daybeds sont parfaits pour se relaxer.**



Archiproducts Design Awards 2018—Winner

Coast (Elmo®) pigmented & printed leather

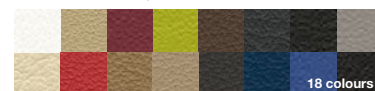

Elmosoft (Elmo®) semi-aniline leather



Elmotique (Elmo®) aniline leather

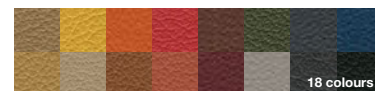

Curmi (Torri Lana®) fabric

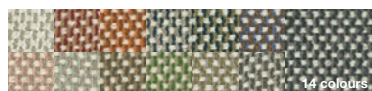

Regal (Erimiti®) velvet fabric



Scuba (Kvadrat®) fabric



Extrema AU (Flukso®) synthetic leather





Tuile 3-seat sofa
Upholstered Regal velvet fabric

CU occasional table
L. 45 cm

Mustache—SA rug
SA-03 terracotta brown

Tuile



Tuile armchair
Upholstered Steelcut Trio 3/Hero fabrics



Tuile 3-seat sofa
Upholstered Steelcut Trio 3 fabric



Tuile 2-seat sofa
Upholstered Steelcut Trio 3 fabric



Tuile 2-seat sofa
Upholstered Steelcut Trio 3 fabric



Tuile armchair
Upholstered Steelcut Trio 3 fabric

Degree occasional table
Polypropylene



1



2



3

Type

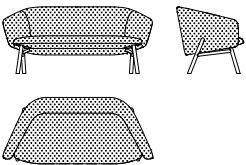

2-seater sofa
L 160 P 70 H 71 cm
W 63" D 27 1/8" H 28"

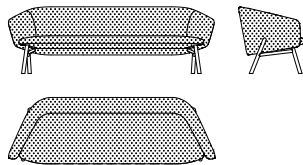

3-seater sofa
L 220 P 70 H 71 cm
W 86 5/8" D 27 1/8" H 28"

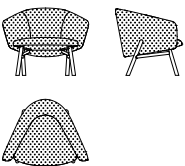

Armchair
L 90 P 70 H 71 cm
W 35 3/8" D 27 1/8" H 28"



4

Tuile

DESIGN BY PATRICK NORGUET, 2017

I Disegnata da Patrick Norguet, la collezione Tuile prende il nome da un biscotto della tradizione francese, sottile e di forma arcuata come lo schienale di questi imbottiti. Tuile comprende una poltrona, un divano due posti e un divano tre posti con una struttura leggera in metallo verniciato e una seduta curva e accogliente, imbottita in schiumato di poliuretano. Il rivestimento in tessuto o pelle – anche con possibilità di combinare due finiture diverse per frontale e schienale – si abbina liberamente ai colori della struttura. Per la manifattura sartoriale e le infinite tonalità disponibili, Tuile è ideale in salotto e in tutti gli ambienti della casa dedicati al relax.

EN Designed by Patrick Norguet, the Tuile collection gets its name from a traditional French biscuit, as it is narrow with an arched shape like the backrest of these upholstered items. The Tuile collection includes an armchair, a 2-seater sofa and a 3-seater sofa with a light painted metal frame and a curved comfortable seat with polyurethane foam padding. The upholstery is made of fabric or leather, including the option of combining two different finishes for the front and back, and can be freely matched with the colours of the frame. With its tailored workmanship and a multitude of colours available, Tuile is ideal in the living room and in all rooms in the home dedicated to relaxation.

DE Die Kollektion Tuile nach einem Entwurf von Patrick Norguet verdankt ihren Namen einem traditionellen französischen Plätzchen, das dieselbe dünne und geschwungene Form wie die Rückenlehne dieser Polstermöbel besitzt. Tuile umfasst einen Sessel, ein Zweisitzer-Sofa und ein Dreisitzer-Sofa mit einer leichten Struktur aus lackiertem Metall und einer gerundeten, einladenden Sitzfläche mit Polsterung aus PUR-Schaumstoff. Der Bezug aus Stoff oder Leder mit der Möglichkeit, zwei unterschiedliche Ausführungen für die Vorder- und Rückseite zu wählen, lässt sich beliebig mit den Farben der Struktur kombinieren. Aufgrund der Fertigung nach bester Schneiderkunst und den unzähligen erhältlichen Farbtönen ist Tuile ideal im Wohnzimmer und in allen Räumen des Hauses, die der Entspannung dienen.

ES Diseñada por Patrick Norguet, la colección Tuile toma su nombre de una galleta de la tradición francesa fina y de forma arqueada como el respaldo de estos asientos. Tuile incluye una butaca, un sofá de dos plazas y un sofá de tres plazas con una ligera estructura de metal barnizado y un asiento curvo y acogedor, con relleno de espuma de poliuretano. El revestimiento de tejido o piel – con posibilidad de utilizar dos acabados distintos para el frente y el respaldo – puede combinarse libremente con los colores de la estructura. Por su manufactura sartorial y las infinitas tonalidades disponibles, Tuile es ideal en el salón y en todos los ambientes de la casa dedicados al relax.

FR Dessinée par Patrick Norguet, la collection Tuile prend le nom d'un petit gâteau de la tradition française, fin et de forme courbe comme le dossier de ces sièges. Elle comprend un fauteuil, un canapé deux places et un canapé trois places, dotés d'une structure légère en métal laqué et une assise courbe et accueillante garnie en mousse de polyuréthane. Le revêtement en tissu ou en cuir – avec possibilité de combiner les deux finitions sur la face avant et arrière du siège – s'associe en toute liberté aux coloris de la structure. De par sa réalisation artisanale et l'infinité de coloris proposés, Tuile est idéal pour le salon et pour tous les espaces intérieurs dédiés à la détente.

Metal base



Hero (Kvadrat®) fabric

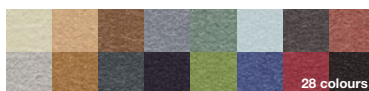

Steelcut Trio 3 (Kvadrat®) fabric

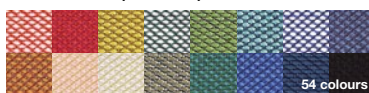

Field 2 (Kvadrat®) fabric



Divina Melange 2 (Kvadrat®) fabric

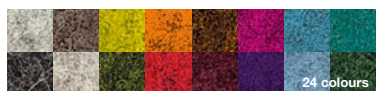

Divina MD (Kvadrat®) fabric

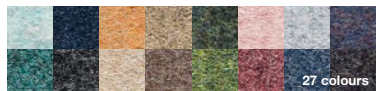

Curmi (Torri Lana®) fabric

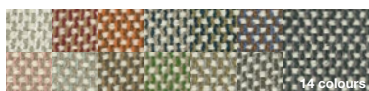

Regal (Erimiti®) velvet fabric



Scuba (Kvadrat®) fabric



Extrema AU (Flukso®) synthetic leather

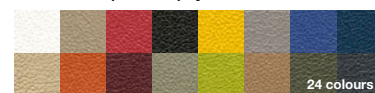

Coast (Elmo®) pigmented & printed leather

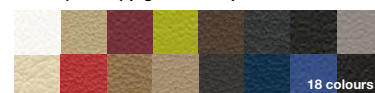

Elmosoft (Elmo®) semi-aniline leather



Elmotique (Elmo®) aniline leather

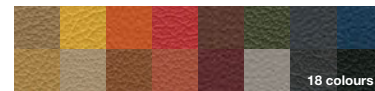



Sharky chair - wooden base
Frontal upholstered Hero fabric

Maki table
Pure-white laminate top

Sharky





Sharky chair - wooden base
Polyurethane body / Frontal upholstered Divina MD fabric

BNC table
Laminate top



Sharky stool - wooden base
High back polyurethane



Sharky stool - aluminium base
Low back frontal upholstered Hero fabric



Sharky stool - wooden base
Low back frontal upholstered Hero fabric



Wood and painted aluminium legs

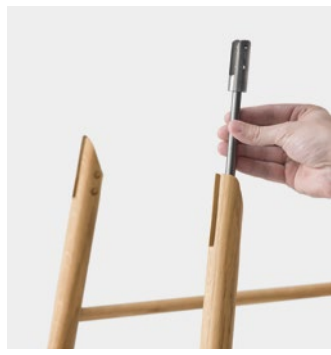

Wood legs



Cycling technology

Type



Wooden base
L 45 P 54 H 81 cm
W 17⁵/₈" D 21²/₈" H 31⁷/₈"



Stool with low back - wooden base
L 45 P 53 H 82-92 cm
W 17⁵/₈" D 20⁷/₈" H 32²/₈-36²/₈"



Aluminium base
L 45 P 54 H 81 cm
W 17⁵/₈" D 21²/₈" H 31⁷/₈"



Stool with low back - aluminium base
L 44 P 51 H 82-92 cm
W 17³/₈" D 20¹/₈" H 32²/₈-36²/₈"



Stool with high back - wooden base
L 48 P 57 H 101-111 cm
W 18⁷/₈" D 22⁴/₈" H 39⁶/₈-43⁶/₈"



Sharky cushion, Lips-R
Removable cushions



Stool with high back - aluminium base
L 48 P 57 H 101-111 cm
W 18⁷/₈" D 22⁴/₈" H 39⁶/₈-43⁶/₈"

Soft options



Sharky removable cushion



Lips-R removable cushion



Frontal upholstered version



Sharky removable cushion



Lips-R removable cushion



Frontal upholstered version

Sharky

DESIGN BY NEULAND, 2014

▣ L'osservazione della natura, unita a una profonda conoscenza degli stili di vita contemporanei, è alla base della filosofia di Eva Paster e Michael Geldmacher. Per realizzare le giunture tra la scocca e la base della sedia Sharky, premiata nel 2015 con l'Interior Innovation Award, i designer si sono ispirati alla leggerezza e alla forza delle pinne degli squali. Il risultato è una seduta sinuosa, sottile ma resistentissima. Sharky – nelle versioni sedia, sgabello con schienale alto e sgabello con schienale basso – è disponibile con gambe in legno o in alluminio verniciato con saldature a vista. La scocca in poliuretano è resa ancora più comoda dalla seduta imbottita o dai cuscini, in tantissimi colori.

EN The philosophy of Eva Paster and Michael Geldmacher is based on observing nature and on a profound knowledge of contemporary lifestyles. To create the coupling elements between the structure and base of the Sharky chair, which won the Interior Innovation Award in 2015, the designers were inspired by the lightness and strength of shark fins. The result is a slimline, sinuous yet very hardwearing seat.

The Sharky chair, stool with a high backrest and stool with a low backrest are available with wood legs or with painted aluminium legs with visible welded details. The polyurethane structure is made even more comfortable with a padded seat or cushions, available in a wide variety of colours.

Wood base



Aluminium base

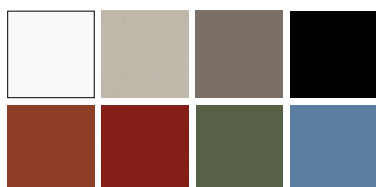

DE Die Beobachtung der Natur, kombiniert mit einem tiefen Wissen über den zeitgenössischen Lebensstil, bildet die Grundlage der Philosophie von Eva Paster und Michael Geldmacher. Für die Realisierung der Verbindungselemente zwischen dem Aufbau und dem Untergestell des im Jahr 2015 mit dem Interior Innovation Award ausgezeichneten Stuhls Sharky ließen sich die Designer von der Leichtigkeit und der Stärke der Haifischflossen inspirieren. Das Ergebnis ist ein kurvig, schlankes, aber dennoch äußerst widerstandsfähiges Sitzmöbel. Sharky wird in den Versionen als Stuhl, Hocker mit hoher Lehne und Hocker mit niedriger Lehne angeboten und ist mit Beinen aus Holz oder aus Aluminium mit sichtbaren Schweißstellen erhältlich. Der Aufbau aus Polyurethan wird durch die gepolsterte Sitzfläche oder durch Kissen in vielen Farben noch bequemer.

ES La observación de la naturaleza, unida a un profundo conocimiento de los estilos de vida contemporáneos, constituye la base de la filosofía de Eva Paster y Michael Geldmacher. Para realizar las uniones entre el bastidor y la base de la silla Sharky, premiada en el año 2015 con el Interior Innovation Award, los diseñadores se han inspirado en la fuerza y la ligereza de las aletas de los tiburones. El resultado es una silla sinuosa, fina pero superresistente. Sharky – en las versiones silla, taburete con respaldo alto y taburete con respaldo bajo – está disponible con patas de madera o de aluminio barnizado con soldaduras a la vista. El bastidor de poliuretano

resulta todavía más cómodo con el asiento con relleno o los cojines, disponibles en muchísimos colores.

FR L'observation de la nature ainsi qu'une profonde connaissance des styles de vie contemporains sont à l'origine de la philosophie d'Eva Paster et de Michael Geldmacher. Pour réaliser l'union entre la coque et les pieds de la chaise Sharky, récompensée en 2015 par l'Interior Innovation Award, les designers se sont inspirés de la légèreté et de la force des nageoires du requin. Le résultat est un siège sinueux, fin, mais très résistant. Sharky – en version chaise ou tabouret avec dossier haut ou bas – existe avec pieds en bois ou en aluminium laqué avec soudures apparentes. La coque en polyuréthane est encore plus confortable grâce à une assise garnie ou à des coussins en divers coloris.

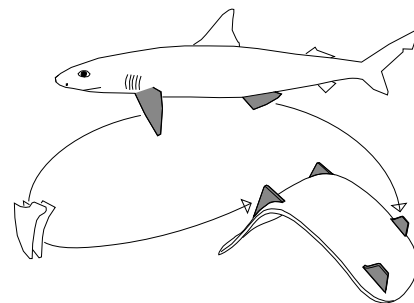

Polyurethane body



Frontal upholstery



Frontal upholstery



Interior Innovation Award 2015—Winner



Elephant wooden base armchair
Polyurethane body

Lips—R removable cushion
Upholstered Field 2 fabric

Mustache—GA rug
GA-02 terracotta brown

Elephant



Elephant armchair
Polyurethane body

Elephant removable cushion
Upholstered Steelcut Trio 3 fabric



Elephant swivel trestle armchair
Upholstered "full-grain" hide





Elephant rocking armchair
Upholstered Divina MD fabric

Degree occasional table
Polypropylene/Cork



Elephant 5—spoke with castors armchair
Upholstered Divina MD fabric



Elephant lounge armchair
Upholstered Regal velvet fabric



Elephant armchair
Upholstered Hero fabric



Swivel trestle



Swivel trestle detail



Slide frame



Upholstered Steelcut Trio 3 fabric



Hand-stitched



Upholstered Regal velvet fabric



1

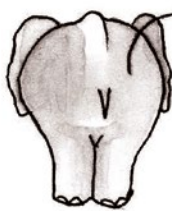

2

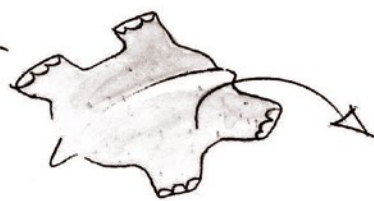

Hide upholstery

Type



Four legs
L 62 P 60 H 84 cm
W 24 3/8" D 23 5/8" H 33 1/8"



Lounge
L 62 P 63 H 75 cm
W 24 3/8" D 24 6/8" H 29 4/8"

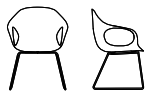

Slide frame
L 62 P 60 H 84 cm
W 24 3/8" D 23 5/8" H 33 1/8"



Rocking
L 62 P 84 H 81 cm
W 24 3/8" D 33 1/8" H 31 7/8"



Wooden base
L 62 P 58 H 85 cm
W 24 3/8" D 22 7/8" H 33 4/8"

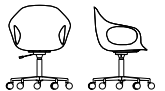

5-spoke base with castors
L 71 P 71 H 81/90 cm
W 28" D 28" H 31 7/8/35 3/8"



Swivel trestle
L 71 P 71 H 83 cm
W 28" D 28" H 32 5/8"



Elephant cushion, Lips—R/S
Removable cushions

Soft options



Elephant removable cushion



Lips—R removable cushion



Lips—S removable cushion



Fabric upholstery

Elephant

DESIGN BY NEULAND, 2010

IT A partire da una struttura molto semplice, Eva Paster e Michael Geldmacher di Neuland danno vita a un progetto estremamente innovativo, premiato nel 2012 con l'Interior Innovation Award. La chiave del successo di questa poltroncina best seller è la sua versatilità, che ne consente una pressoché continua evoluzione, oltre alla qualità delle lavorazioni sartoriali dei rivestimenti. La scocca è disponibile in poliuretano, anche con cuscini; imbottita e rivestita in cuoio, con la caratteristica nervatura di rinforzo che ricorda la spina dorsale di un elefante; imbottita e rivestita in tessuto, con cuciture fatte a mano. Oltre alle gambe in legno o metallo, la sedia può avere la base a slitta, a dondolo, girevole o con ruote.

EN Starting from a very simple frame, Eva Paster and Michael Geldmacher of Neuland created an extremely innovative project that received an Interior Innovation Award in 2012. The key to the success of this best-selling armchair is its versatility, which allows it to evolve almost continuously, not to mention the high-quality tailored workmanship of the upholstery. The structure is available in polyurethane, with cushions; padded and covered in hide, with the characteristic reinforced ribbing reminiscent of the backbone of an elephant; padded and upholstered in fabric, with hand-stitched seams. In addition to wood or metal legs, the chair is available with a slide-frame base, rocking base, swivel base or castors.

DE Ausgehend von einer sehr einfachen Struktur haben Eva Paster und Michael Geldmacher vom Studio Neuland ein absolut innovatives Projekt gestartet, das 2012 mit dem Interior Innovation Award ausgezeichnet wurde. Der Schlüssel des Erfolgs dieses Bestseller-Sessels liegt in seiner Vielseitigkeit, die es ihm erlaubt, sich beinahe fortlaufend weiterzuentwickeln. Ein weiterer Vorzug ist die Qualität der mit Maßarbeit erzeugten Bezüge. Der Aufbau aus Polyurethan ist auch mit Kissen erhältlich und wird außerdem mit Polsterung und Lederbezug mit der charakteristischen Rippenverstärkung, die an das Rückgrat eines Elefanten erinnert, oder mit Polsterung und Stoffbezug mit von Hand angebrachten Nähten angeboten. Neben den Beinen aus Holz oder Metall lässt sich der Sessel Elephant auch mit Kufen, einem Drehgestell, mit Rollen oder mit einem Schaukelstuhlgestell ausrüsten.

ES Partiendo de una estructura muy simple, Eva Paster y Michael Geldmacher de Neuland dan vida a un proyecto extraordinariamente innovador, premiado en el año 2012 con el Interior Innovation Award. La clave del éxito de esta butaca superventas es su gran versatilidad, que permite una evolución prácticamente continua, así como la alta calidad de la confección sartorial de sus revestimientos. El bastidor está disponible en poliuretano, también con cojines; con relleno y revestido en cuero, con la típica nervadura de refuerzo que recuerda la espina dorsal de un elefante; y con relleno y

revestido en tejido, con costuras realizadas a mano. Además de las patas de madera o metal, la silla puede tener base de trineo, mecedora, giratoria o con ruedas.

FR En partant d'un piètement très simple, Eva Paster et Michael Geldmacher de Neuland ont créé un projet extrêmement innovant, récompensé en 2012 par l'Interior Innovation Award. Outre la qualité de la confection artisanale des revêtements, la clé du succès de ce fauteuil best-seller est sa flexibilité qui permet de l'innover continuellement. La coque existe en polyuréthane et peut avoir des coussins. Elle peut également être garnie et revêtue soit en cuir, avec la caractéristique nervure de renfort rappelant l'épine dorsale d'un éléphant soit en tissu avec surpiqures cousues main. Outre les pieds en bois ou en métal, il existe le piètement luge, à bascule, pivotant ou avec roulettes.



Interior Innovation Award 2012—Best of Best

Metal base



Wood base



Polyurethane body



Cuoietto hide body

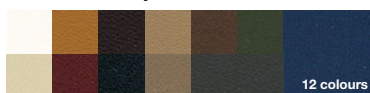

Full-grain hide body



Upholstered body





1085 Edition chair
Natural full-grain hide body

1085 Edition



1085 Edition lounge armchair
Natural full-grain hide body

1085 Edition chair
Black full-grain hide body



1085 Edition chair
Natural full-grain hide body



1085 Edition chair
Black full-grain hide body





1085 Edition lounge armchair
Natural/black full-grain hide body

Constellations occasional table
H. 31 cm



Maquette



Leather processing phase

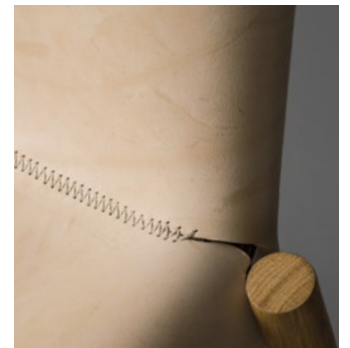

Hand-stitched



1085 Edition

DESIGN BY BARTOLI DESIGN, 2015

Il saperi artigianali, il tempo che passa, la bellezza di un progetto ineguagliabile. La sedia 1085 Edition di Bartoli Design si ispira all'esperienza quasi centenaria di Presot®, unica conceria in Italia a lavorare ancora il cuoio con metodi tradizionali, non a caso legata ad alcuni dei nomi più importanti dell'alta moda italiana. Ma attinge anche al sapere nautico, perché riprende il meccanismo dei tiranti per mantenere la tensione che naturalmente si perderebbe con gli anni e l'ammorbidirsi del cuoio. Infine riflette il tempo che passa, conservando i segni di chi l'ha fatta e di chi, giorno dopo giorno, la usa. Un oggetto prezioso, che ha il fascino del pezzo unico. 1085 Edition è disponibile in versione sedia o lounge, in cuoio naturale o nero.

Artisan skills, the passage of time and the beauty of an unparalleled project. The 1085 Edition chair by Bartoli Design is inspired by the almost hundred-year-old experience of Presot®, the only tannery in Italy that still works leather using traditional methods. Not by chance is it linked to some of the most important names in Italian haute couture. However, it also draws on nautical know-how, as it adopts the tie rod mechanism to retain the tension that would naturally be lost over the years and with the softening of the leather. It also reflects time that passes, preserving the work of those who made it and those who use it day after day. This fine object has the charm of a unique furnishing item. 1085 Edition is available in a chair or lounge version, in natural or black hide.

Type

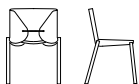

Chair

L 52 P 52 H 78 cm
W 20^{1/8}" D 20^{1/8}" H 30^{5/8}"



Lounge

L 66 P 68 H 76 cm
W 26" D 26^{5/8}" H 29^{7/8}"

Das handwerkliche Können, das Vergehen der Zeit, die Schönheit eines unvergleichlichen Entwurfs. Der Stuhl 1085 Edition von Bartoli Design inspiriert sich an der beinahe hundertjährigen Erfahrung von Presot®, die einzige Gerberei Italiens, die das Leder noch mit traditionellen Methoden bearbeitet und nicht aus Zufall mit einigen der bedeutendsten Namen der italienischen Haute Couture verbunden ist. Der Entwurf greift aber auch auf nautisches Wissen zurück, denn es setzt den Mechanismus von Zugankern ein, um die Spannung aufrechtzuerhalten, die natürlich im Laufe der Jahre und durch das Weicherwerden des Leders nachlassen kann. Und zum Schluss spiegelt er das Vergehen der Zeit wider und bewahrt die Zeichen derer, die ihn Tag für Tag benutzen. Ein kostbarer Gegenstand, der den Charme eines Einzelstücks besitzt. 1085 Edition ist in der Version als Stuhl oder Loungesessel in Naturleder oder in schwarzem Leder erhältlich.

La pericia artesanal, el tiempo que pasa, la belleza de un proyecto inigualable. La silla 1085 Edition de Bartoli Design se inspira en la experiencia casi centenaria de Presot®, la única curtiduría italiana que sigue trabajando el cuero con métodos tradicionales, unida forzosamente a algunos de los nombres más importantes de la alta moda italiana. Pero también se inspira en el saber náutico, porque retoma el mecanismo de los tirantes para mantener la tensión que con los años y con el ablandamiento del cuero llegaría a

perdersse naturalmente. Por último, refleja el tiempo que pasa, conservando las huellas de quien la ha realizado y de quien, día a día, la utiliza. Un objeto precioso, con el encanto de una pieza única. 1085 Edition está disponible en versión silla o lounge, en cuero natural o negro.

Le savoir artisanal, le temps qui passe, la beauté d'un projet sans égal. La chaise 1085 Edition de Bartoli Design s'inspire de l'expérience quasi centenaire de Presot®, unique tannerie italienne travaillant encore le cuir avec des méthodes traditionnelles et liée à certains grands noms de la haute couture italienne. Elle s'inspire aussi du monde nautique en reprenant le mécanisme des haubans pour garder la tension qui se perd lorsque le cuir s'assouplit. Elle reflète enfin le temps qui passe, en conservant les traces de celui qui l'a réalisée et de ceux qui l'utilisent au quotidien. Un objet précieux et unique. 1085 Edition existe en version chaise ou fauteuil, en cuir naturel ou noir.

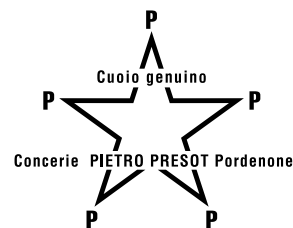

Wood base



Full-grain hide body (Presot®)





Dua wooden legs armchair
Upholstered Regal velvet fabric

Dua wooden legs chair
Upholstered Steelcut Trio 3 fabric

Holo table
Wooden top

Dua





Dua wooden legs chair
Upholstered Steelcut Trio 3 fabric

Dua wooden legs armchair
Upholstered Regal velvet fabric



Dua on slide frame armchair
Upholstered Regal velvet fabric/Elmosoft leather



1



2



3

Type



Chair on wooden legs
L 47 P 53 H 81 cm
W 18⁴/₈" D 20⁷/₈" H 31⁷/₈"

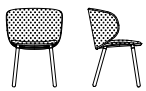

Armchair on wooden legs
L 58 P 53 H 81 cm
W 22⁷/₈" D 20⁷/₈" H 31⁷/₈"



Chair on slide frame
L 47 P 53 H 81 cm
W 18⁴/₈" D 20⁷/₈" H 31⁷/₈"



Armchair on slide frame
L 58 P 53 H 81 cm
W 22⁷/₈" D 20⁷/₈" H 31⁷/₈"



4

Dua

DESIGN BY LÄUFER & KEICHEL, 2018

DE Lo studio berlinese Läufer & Keichel crea per Kristalia una sedia e una poltroncina dalle linee morbide e accoglienti. Il nome richiama il numero due, che ricorre in tutto il progetto a partire dalle due superfici ellittiche del sedile e dello schienale, che ruota sensualmente attorno alla seduta. Disponibili con base a slitta o con quattro gambe in legno massello, sedia e poltroncina possono essere rivestite con i tessuti e le pelli a catalogo, con possibilità di differenziare il rivestimento di seduta e schienale per creare abbinamenti a contrasto o in tinta.

EN **The Berlin-based studio Läufer & Keichel has created a chair and an armchair for Kristalia with soft, embracing lines. The name recalls the number two, which recurs throughout the design project starting with the two elliptical surfaces of the seat and backrest, which sensually revolves around the seat. Available with a slide-frame base or with four solid wood legs, the chair and armchair can be upholstered with the fabrics and leather in the catalogue, with the option of different upholstery for the seat and backrest to create contrasting or matching combinations.**

ES Das Designerstudio Läufer & Keichel in Berlin hat für Kristalia einen Stuhl und einen Sessel mit weichen und einladenden Linien geschaffen. Der Name bezieht sich auf die Zahl zwei, die überall im Entwurf auftaucht, beginnend bei den beiden ellipsenförmigen Flächen des Sitzes und der

Rückenlehne, die sich sinnlich um das Sitzmöbel schmiegt. Stuhl und Sessel sind mit Kufengestell oder vier Beinen aus Massivholz erhältlich und können mit den im Katalog enthaltenen Stoff- und Ledervarianten bezogen werden. Für die Sitzfläche und Rückenlehne stehen außerdem unterschiedliche Bezüge zur Auswahl, um Kombinationen in gleichem Ton oder in Kontrastfarbe zu erzeugen.

ES El estudio berlinés Läufer & Keichel crea para Kristalia una silla y una butaca de líneas suaves y acogedoras. Su nombre evoca el número dos que se repite en todo el proyecto, empezando por las dos superficies elípticas del asiento y del respaldo, que se encurva sensualmente en torno a la silla. Disponibles con base de trineo o con cuatro patas de madera maciza, la silla y la butaca pueden revestirse con los tejidos y las pieles del catálogo y ofrecen la posibilidad de diferenciar el revestimiento del asiento y el respaldo para crear combinaciones en contraste o a juego.

FR L'agence berlinoise Läufer & Keichel a créé, pour Kristalia, une chaise et un fauteuil aux lignes douces et accueillantes. Le nom rappelle le numéro deux que l'on retrouve dans tout le projet, à partir des deux surfaces elliptiques de l'assise et du dossier qui s'enroule sensuellement autour de l'assise. Déclinés avec pieds lège ou avec quatre pieds en bois massif, la chaise et le fauteuil peuvent être revêtus avec les tissus et les cuirs du catalogue, avec

possibilité de différencier l'assise et le dossier pour créer des associations contrastantes ou assorties.

Wood legs



Metal base



Underseat frame



Upholstery body

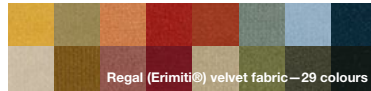
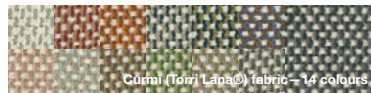
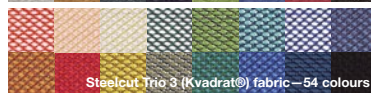
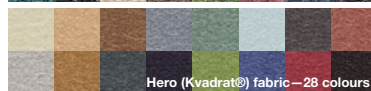
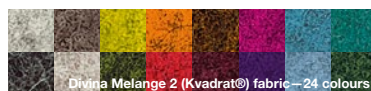

Upholstery body

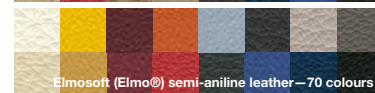



Joko chair
Upholstered Steelcut Trio 3 fabric

Joko



Joko chair
Upholstered Divina Melange 2 / Scuba fabrics



Joko armchair
Upholstered Divina MD fabric

Boiaccia table
Cement version



Joko stool
Upholstered Steelcut Trio 3/Scuba fabrics



1



2



3



4

Joko

DESIGN BY BARTOLI DESIGN, 2010

▣ Progettata da Bartoli Design, uno dei nomi storici di Kristalia, la collezione Joko si è sviluppata a partire da una sedia, poetica ed essenziale. Un'espressione di massima riduzione formale, eppure morbida e amichevole, cui nel tempo hanno fatto seguito la poltroncina con braccioli e gli sgabelli in due altezze; un'evoluzione in continuo divenire, che non può ancora dirsi finita. Completamente rivestita in tessuto o pelle, Joko è realizzata con cura sartoriale. Pressoché infinite le possibilità di personalizzazione, grazie alle tante finiture disponibili in costante aggiornamento.

EN **Designed by Bartoli Design, one of Kristalia's long-standing partners, the Joko collection has evolved from a poetic minimalist chair. Although it expresses the utmost formal minimalism, it is soft and user-friendly. Over time, it has been succeeded by the chair with armrests and stools in two different heights, a continuously developing evolution, which cannot be said to be over yet. Entirely upholstered in fabric or leather, Joko is made with tailored craftsmanship. It offers almost countless options for customisation, thanks to the many finishes available that are constantly updated.**

DE Die Kollektion Joko nach einem Entwurf von Bartoli Design, langjährige Mitarbeiter von Kristalia, nahm mit einem poetischen und essenziellen Stuhl ihren Anfang. Ein Ausdruck maximaler formaler Reduzierung, aber trotzdem

weich und freundlich, dem im Laufe der Zeit ein Sessel mit Armlehnen und die Hocker in zwei Höhen folgten: eine fortlaufende Evolution, die noch lange nicht zu Ende ist. Joko ist vollständig mit Stoff oder Leder bezogen und wird nach bestem Schneiderhandwerk hergestellt. Dank der vielen erhältlichen und ständig aktualisierten Ausführungen sind die individuellen Gestaltungsmöglichkeiten nahezu unendlich.

ES Diseñada por Bartoli Design, uno de los nombres históricos de Kristalia, la colección Joko se ha desarrollado a partir de una silla poética y esencial. Una expresión de máxima reducción formal pero suave y acogedora a la vez, seguida luego en el tiempo por la butaca con brazos y los taburetes en dos alturas: una evolución en continuo devenir, que todavía no puede darse por acabada. Completamente revestida en tejido o piel, Joko está realizada con atención artesanal. Sus posibilidades de personalización son prácticamente infinitas, gracias a los múltiples acabados disponibles y en continua actualización.

FR Conçue par Bartoli Design, l'un des noms historiques de Kristalia, la collection Joko s'est développée à partir d'une chaise, poétique et épurée. Une expression de réduction de la forme maximale, et pourtant douce et conviviale, qui a continué son chemin avec le fauteuil avec accoudoirs et les tabourets en deux hauteurs. Une transformation continuelle de la forme, qui n'est pas encore épuisée. Entièrement revêtue en

tissu ou en cuir, Joko est réalisée avec un soin artisanal. Les possibilités de personnalisation sont pratiquement infinies grâce aux nombreuses finitions proposées et constamment mises à jour.

Type

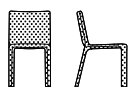

Chair
L 44 P 54 H 80 cm
W 17^{3/8}" D 21^{3/8}" H 31^{4/8}"



Armchair
L 59 P 54 H 80 cm
W 23^{2/8}" D 21^{3/8}" H 31^{4/8}"

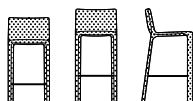

Stool
L 45 P 52 H 89-99 cm
W 17^{5/8}" D 20^{1/8}" H 35-39"

Divina Melange 2 (Kvadrat®) fabric



Divina MD (Kvadrat®) fabric



Hero (Kvadrat®) fabric

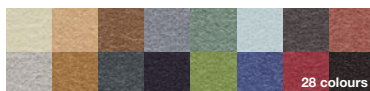

Steelcut Trio 3 (Kvadrat®) fabric

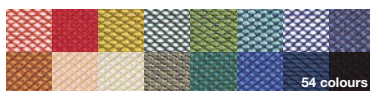

Field 2 (Kvadrat®) fabric



Scuba (Kvadrat®) fabric



Extrema AU (Flukso®) synthetic leather

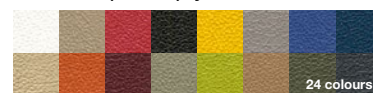

Coast (Elmo®) pigmented & printed leather

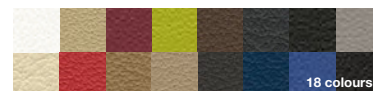

Elmosoft (Elmo®) semi-aniline leather



Elmotique (Elmo®) aniline leather

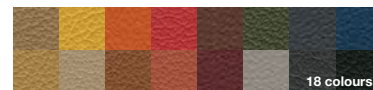



LP chair
Polypropylene w/ frontal removable upholstery Hero fabric

be—Easy table
Fenix-NTM® top



LP chair
Polypropylene



1



2



3

Soft options



Removable frontal upholstery



Lips—R removable cushion



Lips—S removable cushion

LP

DESIGN BY LUCIDIPEVERE, 2016

▣ Ideata dal duo di designer LucidiPevere, LP è una sedia essenziale ed eclettica. È realizzata in polipropilene rinforzato in fibra di vetro e stampato a iniezione, un materiale che dona alla superficie un aspetto opaco e piacevole al tatto. Nella nuova versione, LP può essere accompagnata dai cuscini rimovibili Lips in due varianti oppure abbinata al rivestimento rimovibile di seduta e schienale: accessori che la rendono ancora più confortevole, oltre a permettere interessanti combinazioni cromatiche tra i tessuti e la sedia, in cinque colori. Resistente e impilabile, LP è adatta alle più diverse situazioni, dagli spazi di casa a quelli collettivi, sia indoor che outdoor.

EN Created by the designer duo LucidiPevere, LP is a versatile minimalist chair. It is made of injection-moulded and fibre glass-reinforced polypropylene, a material that gives the surface a matt aspect that is pleasant to the touch. The new version of LP can be accompanied by removable Lips cushions in two versions or combined with removable seat and backrest upholstery: accessories make it even more comfortable while providing interesting colour contrasts between the fabrics and the chair in five different colours. Hard-wearing and stackable, LP is ideal for the most varied indoor and outdoor contexts, including the home and community spaces.

DE Der vom Designerduo LucidiPevere entworfene Stuhl LP ist ein essenzielles und

vielseitiges Modell. Er besteht aus glasfaserverstärktem und spritzgegossenem Polypropylen, ein Material, das der Oberfläche ein mattes und berührungsfreundliches Aussehen schenkt. In der neuen Version kann LP mit den abnehmbaren Kissen Lips in zwei Varianten kombiniert oder mit dem abnehmbaren Bezug für Sitzfläche und Rückenlehne ergänzt werden. Accessoires, die das Sitzmöbel noch einladender machen und interessante Farbkombinationen zwischen den Stoffen und dem in fünf Farben erhältlichen Stuhl ermöglichen. LP ist widerstandsfähig und stapelbar und eignet sich für die unterschiedlichsten Einrichtungssituationen, von Wohn- bis zu Gemeinschaftsräumen und für Indoor- und Outdoorbereiche.

ES Ideada por el dúo de diseñadores LucidiPevere, LP es una silla esencial y ecléctica. Está realizada en polipropileno reforzado con fibra de vidrio y moldeado por inyección, un material que confiere a la superficie un aspecto mate y agradable al tacto. En la nueva versión, LP puede acompañarse con los cojines extraíbles Lips en dos variantes o combinarse con el revestimiento extraíble del asiento y el respaldo: accesorios que la hacen todavía más confortable, además de permitir interesantes asociaciones cromáticas entre los tejidos y la silla, en cinco colores. Resistente y apilable, LP se adapta a las situaciones más variadas, de los espacios domésticos a los colectivos, tanto interiores como exteriores.

FR Créée par les designers LucidiPevere, LP est une chaise épurée et éclectique. Elle est réalisée en polypropylène renforcé avec des fibres de verre et moulé par injection, un matériau qui donne à la surface un aspect mat et agréable au toucher. Dans sa nouvelle version, LP peut avoir soit les coussins amovibles Lips en deux variantes soit un revêtement assise-dossier amovible : des accessoires qui la rendent non seulement plus confortable, mais qui permettent d'intéressantes combinaisons de couleurs entre les tissus et la chaise en cinq coloris. Résistante et empilable, LP convient tant aux espaces domestiques qu'aux espaces collectifs, à l'intérieur comme à l'extérieur.

Type



Stackable chair
L 53 P 52 H 77 cm
W 20^{7/8}" D 20^{1/8}" H 30^{3/8}"



Stackable armchair
L 59 P 52 H 77 cm
W 23^{2/8}" D 20^{1/8}" H 30^{3/8}"



Frontal removable upholstery



Lips—R/S
Removable cushions

Polypropylene (Silky-touch finish)



Removable frontal upholstery



Removable frontal upholstery





Rama chair - four wood legs
Frontal upholstered Hero fabric

Boiaccia table
Wood version

Rama



Rama chair - four wood legs
Frontal upholstered Divina MD fabric



Rama chair - four legs
Wooden body

Lips—R removable cushion
Upholstered Hero fabric

TNP table
Bistro



Rama armchair - slide frame
Polypropylene body

Lips—R removable cushion
Upholstered Field 2 fabric

Degree occasional table
Cork





Rama stool
Polypropylene body

Lips—R removable cushion
Upholstered Field 2 fabric



1

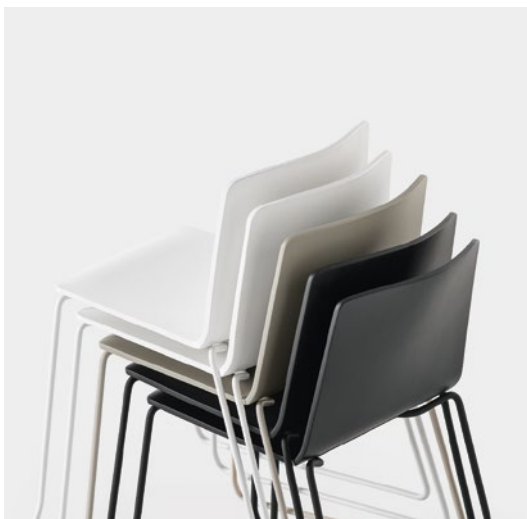

2

Type



Four legs - stackable
L 54 P 54 H 75 cm
W 21¹/₈" D 21¹/₈" H 29³/₈"



Stackable stool
L 54 P 54 H 95-105 cm
W 21¹/₈" D 21¹/₈" H 37³/₈-41³/₈"



Four wood legs - stackable
L 54 P 55 H 75 cm
W 21¹/₈" D 21¹/₈" H 29³/₈"



Lips—R
Removable cushion



Slide frame - stackable
L 54 P 54 H 75 cm
W 21¹/₈" D 21¹/₈" H 29³/₈"



Slide frame with armrests - stackable
L 55 P 54 H 75 cm
W 21¹/₈" D 21¹/₈" H 29³/₈"

Soft options



Lips—R removable cushion



Frontal upholstered version



Fully upholstered version

Rama

DESIGN BY RAMOS BASSOLS, 2014

▣ Seduta impilabile dal segno preciso ed essenziale, con scocca in legno multistrato curvato oppure, in alternativa, in polipropilene rinforzato stampato ad iniezione. Molteplici le possibilità per la struttura: con gambe in legno massello, anch'esse di qualità artigianale, oppure a quattro gambe o a slitta in tondino metallico con o senza braccioli. A queste versioni si aggiungono i nuovi sgabelli, anch'essi impilabili, in due altezze. La scocca è disponibile anche in versione imbottita, frontalmente o completamente rivestita in diversi tessuti e pelli di alta qualità, che permettono di creare infiniti abbinamenti cromatici con le strutture.

EN **Stackable chair with a distinct and essential style, with a curved plywood structure or, alternatively, in injection-moulded reinforced polypropylene. The frame is available in many versions: with solid wood legs, also demonstrating high-quality craftsmanship, with four legs, or on a tubular metal slide frame with or without armrests. In addition, two new stools are available, also stackable, in two different heights. The structure is also available in a padded version, upholstered either entirely or at the front in a choice of high-quality fabrics and leather, allowing many colour combinations to be created with the frames.**

DE Ein stapelbares Sitzmöbel im präzisen und essentiellen Look mit einem Aufbau aus gerundetem Mehrschichtenholz oder, als Alternative, aus verstärktem spritzgegossenem

Polypropylen. Die Struktur steht in vielzähligen Varianten zur Auswahl: mit Beinen aus Massivholz in handwerklicher Qualitätsverarbeitung oder auf vier Beinen oder auf Kufen aus verchromtem Metallrohr mit oder ohne Armlehnen. Zu diesen Versionen gesellen sich die neuen Hocker in zwei Höhen, die ebenfalls stapelbar sind. Der Aufbau ist auch in gepolsterter Version mit vorderem oder vollständigem Bezug aus verschiedenen hochwertigen Stoffen und Lederarten erhältlich, wodurch unzählige Farbkombinationen mit den Strukturen möglich sind.

ES Silla apilable de carácter preciso y esencial, con bastidor de madera multistrato curvada o de polipropileno reforzado moldeado por inyección. La estructura se presenta en distintas variantes: con patas de madera maciza, también de calidad artesanal, o bien con cuatro patas o sobre trineo de tubo de metal con o sin brazos. A estas versiones se suman los nuevos taburetes, también apilables, en dos alturas. El bastidor está disponible en versión tapizada frontalmente o completamente revestida con distintos tejidos y pieles de alta calidad, que permiten crear infinitas combinaciones cromáticas con las estructuras.

FR Siège empilable aux lignes précises et épurées, dont la coque est disponible soit en bois multiplis plié, soit en polypropylène renforcé moulé par injection. En ce qui concerne la structure, on la propose en de nombreuses

versions: soit avec pieds en bois massif réalisés artisanalement, soit avec quatre pieds ou sur piètement luge en tube métallique, avec ou sans accoudoirs. À ces versions s'ajoutent les nouveaux tabourets, eux aussi empilables, disponibles en deux hauteurs. La coque est également disponible en version garnie, avec revêtement complet ou partiel (uniquement à l'avant) en différents tissus ou cuirs de haute qualité permettant de créer d'innombrables combinaisons chromatiques avec les structures.

Metal base

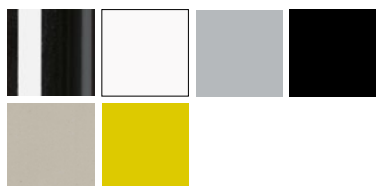

Wood legs



Polypropylene body



Wood body

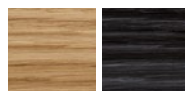

Frontal / fully upholstery



Frontal / fully upholstery





Colander chair
Polypropylene body

Elephant table
Bistro - double base version

Colander



Colander chair
Colour palette



Colander chair
Wooden body



Colander stool
Wooden body



Colander chair
Upholstered body

TNP table
Bistro



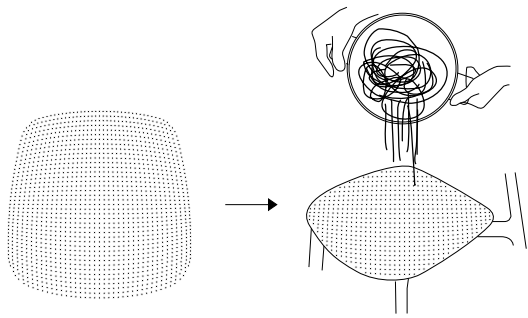

1

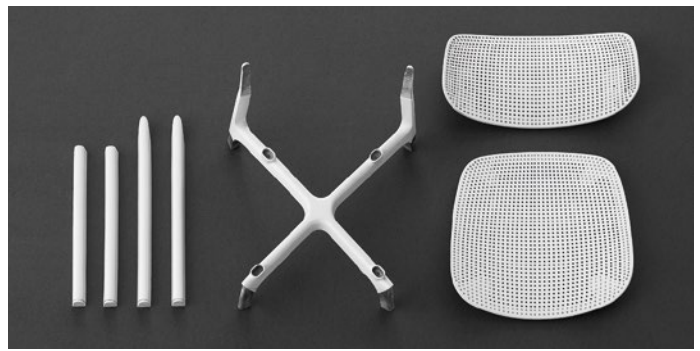

2



3

Type



Stackable chair
 L 47 P 49 H 79 cm
 W 17 1/8" D 19 3/8" H 31 1/8"



Stackable stool
 L 54 P 52 H 98-108 cm
 W 21 1/8" D 20 1/8" H 38 5/8-42 1/8"



Lips-R
 Removable cushion



4

Soft options



Lips-R removable cushion



Lips-R removable cushion



Upholstered version

Colander

DESIGN BY PATRICK NORGUET, 2015

IT Colander traduce in forma di sedia la creatività innovativa di Patrick Norguet, designer francese attento all'evoluzione dei materiali e delle tecnologie. La struttura in alluminio verniciato, leggera e inalterabile, sorregge sedile e schienale, disponibili in tre varianti: quella originaria in polipropilene stampato a iniezione e caratterizzato da una texture forata che ricorda uno scolapasta, da cui la sedia ha preso il nome, e le due nuove versioni in legno curvato e imbottita con rivestimento in tessuto o pelle. Impilabile, mono o bicolore, per l'ampia scelta di finiture Colander può essere usata all'interno degli ambienti più diversi, domestici o collettivi.

EN Colander translates the innovative creativity of Patrick Norguet, the French designer who focuses on the development of materials and technologies, into a chair. The light and unalterable painted aluminium frame supports the seat and backrest, available in three versions: the original version in injection-moulded polypropylene featuring a perforated texture that recalls a colander, hence the name of the chair, and two new versions in curved wood and upholstered in fabric or leather. Stackable, single or two-tone, thanks to a wide choice of finishes Colander can be used in the most varied home or community environments.

DE Colander präsentiert die stuhlgewordene innovative Kreativität von Patrick Norguet, ein französischer Designer, der stets auf die

Weiterentwicklung der Materialien und Technologien bedacht ist. Eine leichte und beständige Struktur aus lackiertem Aluminium trägt die Sitzfläche und die Rückenlehne, die in drei Varianten erhältlich sind: Die ursprüngliche Version aus spritzgegossenem Polypropylen, das sich durch eine gelochte, an einen Nudelsieb erinnernde Textur auszeichnet, die dem Stuhl seinen Namen gibt. Dazu gesellen sich zwei neue Versionen aus gerundetem Holz und gepolstert mit Stoff- oder Lederbezug. Stapelbar, einfarbig oder mehrfarbig... durch das reichhaltige Angebot an Ausführungen lässt sich Colander in den unterschiedlichsten Räumlichkeiten des Heims oder in Gemeinschaftseinrichtungen einsetzen.

ES Colander traduce en forma de silla la innovadora creatividad de Patrick Norguet, diseñador francés atento a la evolución de los materiales y de las tecnologías. Ligera e inalterable, la estructura de aluminio barnizado sostiene el asiento y el respaldo, disponibles en tres variantes: la original de polipropileno moldeado por inyección y caracterizado por una textura perforada semejante a la de un escurridor, de la que toma el nombre la silla, y las dos nuevas versiones de madera curvada, con revestimiento de tejido o piel. Apilable, mono o bicolor, gracias a su amplio surtido de acabados Colander puede ser utilizada en el interior de cualquier ambiente doméstico o colectivo.

FR Colander traduit, sous forme de chaise, la créativité innovante de Patrick Norguet, designer

français attentif à l'évolution des matériaux et des technologies. La structure en aluminium laqué, légère et inaltérable, soutient l'assise et le dossier déclinés en trois variantes : celle d'origine en polypropylène moulé par injection et se distinguant par une surface perforée rappelant une passoire, d'où son nom, et les deux nouvelles versions en bois courbe ou bien garnie et revêtue en tissu ou en cuir. Empilable, monochrome ou bicolore, Colander s'utilise dans des espaces intérieurs, tant domestiques que collectifs, grâce au vaste choix des finitions proposées.

Aluminium base



Polypropylene body

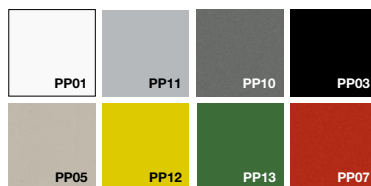

Wood body



Upholstered body



Upholstered body





Compas armchair
PA6-plastic body

Lips—R removable cushion
Upholstered Field 2 fabric

Mustache—RE rug
RE-01 canvas

Compas







Compas armchair
PA6-plastic body with Compas cushion

BNC table
Laminate top



1



Patrick Norguet at work



Compas cushion assembly

Soft options



Compas fixed cushion



Lips—R removable cushion



Lips—S removable cushion

Compas

DESIGN BY PATRICK NORGUET, 2012

La ricerca sui materiali è uno dei motori della creatività di Patrick Norguet, che nella sedia Compas riesce a unire innovazione ed eleganza. La seduta è realizzata in PA6, un materiale plastico resistente e durevole. Le gambe, caratterizzate dall'inclinazione a V rovesciata che ricorda le asticelle di un compasso, sono in pressofusione di alluminio e verniciate a polvere nello stesso colore della seduta. La sedia Compas diventa ancora più confortevole con i cuscini Lips o il cuscino su misura, da personalizzare con i tessuti disponibili e fissare alla seduta con quattro viti.

Research into materials is one of the driving forces behind the creativity of Patrick Norguet, who successfully combines innovation with elegance in the Compas chair. Its seat is made of PA6, a hardwearing and durable plastic material. The legs, featuring an inverted V-shaped tilt reminiscent of the rods of a compass, are made of die-cast aluminium and are powder-coated in the same colour as the seat. The Compas chair becomes even more comfortable with the addition of Lips cushions or a bespoke cushion, which can be customised with the available fabrics and anchored to the seat with four screws.

Die Erforschung von Materialien ist eine der treibenden Kräfte hinter der Kreativität von Patrick Norguet, der es schafft, im Stuhl Compas Innovation und Eleganz zu vereinen. Das Sitzmöbel wird aus PA6 hergestellt, ein

widerstandsfähiges und langlebiges Kunststoffmaterial. Die Beine mit der auffallenden, an die Schenkel eines Zirkels erinnernde Form eines umgedrehten V bestehen aus Aluguss mit Pulverlackierung im Farbton der Sitzfläche. Der Stuhl Compas wird mit den Kissen Lips oder dem maßgefertigten Kissen noch komfortabler. Letzteres steht mit verschiedenen Stoffbezügen zur Auswahl und lässt sich mit vier Schrauben an der Sitzfläche befestigen.

La investigación de los materiales es uno de los motores de la creatividad de Patrick Norguet, que en la silla Compas logra unir innovación y elegancia. El asiento está realizado en PA6, un material plástico resistente y duradero. Las patas, caracterizadas por su inclinación en forma de V invertida que recuerda las varillas de un compás, están realizadas en aluminio moldeado bajo presión y barnizadas con polvo en el mismo color que el asiento. La silla Compas resulta todavía más cómoda con los cojines Lips o con el cojín a medida, que puede personalizarse con los tejidos disponibles y se fija al asiento con cuatro tornillos.

La recherche sur les matériaux est l'un des moteurs de la créativité de Patrick Norguet qui parvient à allier, avec la chaise Compas, l'innovation et l'élégance. L'assise est réalisée en PA6, une matière plastique résistante et durable. Les pieds, se distinguant par leur inclinaison en V inversée rappelant les bras d'un compas, sont

réalisés en aluminium moulé sous pression et laqué époxy dans la même teinte que l'assise et le dossier. La chaise Compas devient encore plus confortable avec les coussins Lips, ou le coussin sur mesure, que l'on pourra personnaliser avec les tissus proposés et fixer à l'assise avec quatre vis.

Type



Stackable armchair
L 57 P 56 H 78 cm
W 22.48" D 22" H 30.68"



With Compas cushion
L 57 P 56 H 78 cm
W 22.48" D 22" H 30.68"



Lips—R/S
Removable cushions



Aluminium legs



PA6-plastic body



Compas fixed cushion

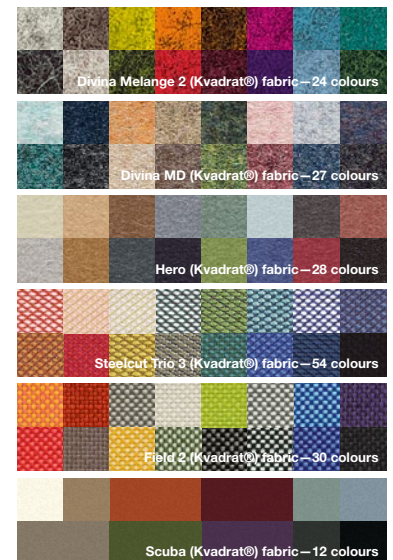



Plana chair
Polypropylene

Nori table
Fenix-NTM® top

Plana



Plana chair
Colour palette



Plana chair
Polypropylene

Plana upholstered chair
Scuba fabric



Plana upholstered chair
Scuba fabric

Nori table
Pure-white laminate top



1



2



3

Soft options



Lips—R removable cushion



Upholstered version

Plana

DESIGN BY LUCIDIPEVERE, 2009

IT Resistente, versatile, accessibile, Plana è una sedia per tutte le occasioni. Disegnata da LucidiPevere, è realizzata in polipropilene rinforzato con vetro e stampato a iniezione. Leggerezza e colore ne fanno la sedia perfetta per gli spazi di casa, mentre il tappo rimovibile per lo scolo dell'acqua nella seduta e l'impilabilità fino a dieci pezzi la rendono ideale anche per l'outdoor. Plana è ancora più confortevole nella versione lievemente imbottita, con rivestimento in pelle sintetica o tessuto, oppure abbinata al cuscino Lips.

EN **Hardwearing, versatile and affordable, Plana is a chair for all occasions. Designed by LucidiPevere, it is made of injection-moulded polypropylene reinforced with glass. Its lightness and colour make it the ideal chair for home spaces, whereas the removable cap in the seat for water drainage and the fact that it can be stacked, up to ten items, make it ideal for outdoor use. Plana is even more comfortable in the slightly padded version, with upholstery in synthetic leather or fabric, or combined with the Lips cushion.**

DE Widerstandsfähig, vielseitig, erschwinglich: Plana ist ein Stuhl für jede Gelegenheit. Der Entwurf stammt von LucidiPevere, für die Herstellung wurde spritzgegossenes Polypropylen mit Glasfaserverstärkung eingesetzt. Leichtigkeit und Farbe machen ihn zum perfekten Stuhl für den häuslichen

Bereich, durch den abnehmbaren Stöpsel für den Abfluss von Regenwasser und die Stapelfähigkeit von bis zu 10 Stück ist er aber auch ideal für die Nutzung im Freien. Noch bequemer ist Plana in der leicht gepolsterten Version mit Bezug aus Lederimitat oder Stoff, oder in Kombination mit dem Kissen Lips.

ES Resistente, versátil, accesible: Plana es una silla para todas las ocasiones. Diseñada por LucidiPevere, está realizada en polipropileno reforzado con vidrio y moldeado por inyección. Su ligereza y su color hacen que sea perfecta en los espacios domésticos, mientras que el tapón extraíble del asiento para la salida del agua y la posibilidad de apilar hasta diez unidades la convierten también en una silla ideal para los ambientes exteriores. Plana resulta todavía más cómoda en la versión provista de ligero relleno, con revestimiento de piel sintética o tejido, o combinada con el cojín Lips.

FR Résistante, polyvalente, prix accessible : Plana est une chaise pour toutes les occasions. Dessinée par LucidiPevere, elle est réalisée en polypropylène renforcé avec des fibres de verre et moulé par injection. La légèreté et la couleur transforment cette chaise en un élément parfait pour les espaces domestiques alors qu'elle est également idéale pour l'extérieur grâce au bouchon amovible sur l'assise permettant l'écoulement de l'eau et à la possibilité d'empiler jusqu'à 10 chaises. Plana est encore

plus confortable en version légèrement garnie et revêtue en cuir synthétique ou en tissu ou bien équipée du coussin Lips.

Type



Stackable chair
L 49 P 53 H 79 cm
W 19^{5/8}" D 20^{7/8}" H 31^{1/8}"



Upholstered chair
L 50 P 54 H 80 cm
W 19^{5/8}" D 21^{2/8}" H 31^{4/8}"



Lips—R
Removable cushion

Polypropylene

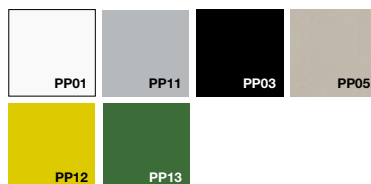

Upholstered body





Mem armchair
Polypropylene

Lips—D removable cushion
Upholstered Field 2 fabric

Nori table
Pure-white laminate top





1



2

Soft options



Mem removable cushion



Lips—D removable cushion

Mem

DESIGN BY CHRISTOPHE PILLET, 2012

Realizzata in polipropilene rinforzato con vetro e stampato a iniezione, con il suo disegno di angoli e curve appena accennate la poltroncina Mem di Christophe Pillet unisce resistenza ed eleganza. I due fori sulla seduta sono dettagli estetici ma anche funzionali, perché rendono la poltroncina impilabile nonostante la sua forma avvolgente.

Mem è disponibile anche con cuscino rimovibile in poliuretano morbido, in tinta con la seduta o a contrasto, o con cuscino lombare rivestito in vari tessuti, che rende la seduta ancora più confortevole.

EN Made of injection-moulded polypropylene reinforced with glass, the Mem chair by Christophe Pillet, with its barely highlighted angles and curves, combines strength with elegance. The two holes in the seat are aesthetic yet also functional details, since they make the chair stackable despite its embracing shape. Mem is also available with a removable soft polyurethane cushion that matches or contrasts with the seat, or with a lumbar cushion upholstered in a choice of fabrics, making the seat even more comfortable.

DE Der aus glasfaserverstärktem und spritzgegossenem Polypropylen hergestellte Sessel Mem von Christophe Pillet vereint in seinem Entwurf mit angedeuteten Kurven und Winkeln Widerstandsfähigkeit und Eleganz. Die beiden Öffnungen in der Sitzfläche sind ein

ästhetisches, aber auch funktionelles Detail, da sie den Sessel trotz der einhüllenden Form stapelbar machen. Mem ist auch mit abnehmbarem Kissen aus weichem Polyurethan im Ton der Sitzfläche oder in Kontrastfarbe erhältlich. Außerdem steht ein in mehreren Stoffvarianten bezogenes Rückenkissen zur Auswahl, das den Stuhl noch behaglicher macht.

ES Realizada en polipropileno reforzado con vidrio y moldeado por inyección, con su diseño de ángulos y curvas ligeramente insinuadas la butaca Mem de Christophe Pillet une resistencia y elegancia. Los dos orificios del asiento son detalles estéticos, pero también funcionales: gracias a ellos la butaca resulta apilable a pesar de su forma envolvente. Mem también está disponible con cojín extraíble de poliuretano suave, a juego con el asiento o en contraste, o con un cojín lumbar revestido con distintos tejidos que aumenta el confort de la silla.

FR Réalisé en polypropylène renforcé avec des fibres de verre et moulé par injection, avec des angles et des courbes à peine esquissées, le fauteuil Mem de Christophe Pillet allie résistance et élégance. Les deux ouvertures sur l'assise sont des détails esthétiques, mais également fonctionnels, puisqu'elles permettent de l'empiler malgré sa forme enveloppante. Mem existe également avec coussin amovible en polyuréthane souple, assorti au fauteuil ou bien en contraste ou avec coussin lombaire revêtu en divers tissus pour un meilleur confort.

Sizes

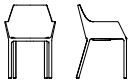

Stackable armchair
L 56 P 58 H 81 cm
W 22" D 22^{7/8}" H 31^{7/8}"



Mem cushion, Lips-D
Removable cushions

Polypropylene



Mem removable cushion (soft polyurethane)





Pulp chair
Polypropylene





1

Soft options



Lips—R removable cushion



Lips—S removable cushion



2

Pulp

DESIGN BY CHRISTOPHE PILLET, 2011

▣ Pulp si inserisce nell'iconica tradizione della seduta cantilever, una tipologia di sedia che fin dal suo primo apparire, negli anni Venti del XX secolo, è diventata una delle sfide del design contemporaneo. Un'idea rivoluzionaria basata sulla convinzione che in un imprecisato futuro potremo sederci, letteralmente, sull'aria. Molti designer si sono cimentati nello studio di forme e soluzioni sempre più all'avanguardia: tra questi Christophe Pillet, che offre con Pulp la sua interpretazione di questa suggestiva metafora. Avvolgente, modellata sulle forme del corpo, Pulp è realizzata in polipropilene bianco o nero, un materiale innovativo per una sedia nata già classica.

EN Pulp can be included in the iconic tradition of cantilever chairs: This type of chair has become one of the challenges of contemporary design since its first appearance in the 1920s. It is based on a revolutionary idea that at some time in the future we will literally be able to sit on air. Many designers have attempted to research increasingly innovative shapes and solutions, including Christophe Pillet, who, with the Pulp chair, offers his interpretation of this evocative metaphor. Embracing and moulded to the shape of the body, Pulp is made of black or white polypropylene, an innovative material for an already classic chair.

▣ Pulp ist ein Teil der ikonischen Tradition von Freischwingern, eine Stuhlart, die seit ihrem

Sizes



Stackable chair

L 53 P 61 H 85 cm
W 20^{7/8}" D 24" H 33^{4/8}"



Lips—R/S
Removable cushions

ersten Auftritt in den 1920er Jahren zu einer der Herausforderungen des zeitgenössischen Designs geworden ist. Eine revolutionäre Idee, die auf der Überzeugung basiert, dass wir uns in einer unbestimmten Zukunft buchstäblich auf Luft setzen werden können. Viele Designer haben versucht, zunehmend avantgardistische Formen und Lösungen zu entwickeln, darunter Christophe Pillet, der mit Pulp seine Interpretation dieser suggestiven Metapher vorstellt. Einhüllend und den Formen und Rundungen des Körpers folgend präsentiert sich Pulp aus weißem oder schwarzem Polypropylen, ein innovatives Material für einen Stuhl, der bereits als Klassiker geboren wurde.

ES Pulp se enmarca en la icónica tradición de la silla cantilever, un modelo que desde su primera aparición en los años veinte del siglo del XX se ha convertido en uno de los desafíos del diseño contemporáneo. Una idea revolucionaria basada en la convicción de que en un futuro todavía desconocido llegaremos a sentarnos literalmente en el aire. Muchos diseñadores han trabajado en el estudio de formas y soluciones cada día más vanguardistas: entre ellos Christophe Pillet, que con Pulp ofrece una interpretación personal de esta sugestiva metáfora. Envoltente, modelada según las formas del cuerpo, Pulp está realizada en polipropileno blanco o negro: un material innovador para una silla que ha nacido ya como un clásico.

▣ Pulp s'insère dans la tradition iconique de la

Polypropylene



chaise cantilever, un type de chaise qui, dès son apparition dans les années Vingt du XXème siècle, est devenu l'un des défis du design contemporain. Une idée révolutionnaire se basant sur la conviction que, dans un avenir imprécisé, nous pourrions nous asseoir littéralement sur l'air. De nombreux designers se sont essayés à l'étude de formes et de solutions toujours plus avant-gardistes : parmi ceux-ci, Christophe Pillet qui offre, avec Pulp, son interprétation de cette suggestiv métaphore. Enveloppante, modelée sur les formes du corps, Pulp est réalisée en polypropylène blanc ou noir, un matériau innovant pour une chaise née déjà classique.





Pikaia chair - slide frame
Polyurethane body

Lips—R removable cushion
Upholstered Field 2 fabric

Pikaia



Pikaia chair - four legs
Polyurethane body



Pikaia armchair - four legs
Polyurethane body

Oops table
Lacquered top



Pikaia 5—spoke with castors armchair
Polyurethane body



1



2

Soft options



Lips—R removable cushion

Pikaia

DESIGN BY ANGELO NATUZZI, 2007

IT Flessibilità è la parola chiave della collezione Pikaia, disegnata da Angelo Natuzzi. La scocca in poliuretano ha uno schienale ergonomico particolarmente elastico, ideale per sostenere la schiena e adattarsi alla forma e al peso del corpo, mentre le nervature alla base gli conferiscono robustezza e resistenza. La collezione conta numerose versioni: la sedia è disponibile con gambe, in versione impilabile, con base a slitta o con ruote, mentre la poltroncina con braccioli si abbina a gambe o ruote. Adatta tanto agli ambienti domestici quanto a quelli collettivi, Pikaia è disponibile in vari colori, anche con cuscino rimovibile per un maggior comfort.

EN Versatility is the key word for the Pikaia collection designed by Angelo Natuzzi. The polyurethane structure has a particularly flexible ergonomic backrest that is ideal for supporting the back and adapting to the shape and weight of the body, whereas the stiffening ribs at the base give it strength and resistance. The collection includes various versions: the chair is available with legs, in stackable version, with a slide-frame base or with castors, whereas the chair with armrests can be combined with legs or castors. Suitable for both home and community environments, Pikaia is available in a variety of colours, also with a removable cushion for greater comfort.

DE Flexibilität ist das Schlüsselwort der Kollektion

Pikaia nach einem Entwurf von Angelo Natuzzi. Der Aufbau aus Polyurethan hat eine besonders elastische ergonomische Rückenlehne, ideal, um den Rücken zu stützen und um sich der Form und dem Gewicht des Körpers anzupassen. Die Rippenform am unteren Ende verleiht der Lehne Stärke und Widerstandsfähigkeit. Die Kollektion umfasst zahlreiche Varianten: Der Stuhl ist mit Beinen, in stapelbarer Version, mit Kufengestell oder mit Rollen erhältlich, der Sessel mit Armlehnen wird hingegen mit Beinen oder Rollen kombiniert. Pikaia ist für den häuslichen Bereich und für Gemeinschaftseinrichtungen gleichermaßen geeignet und steht in verschiedenen Farben oder für größeren Sitzkomfort auch mit einem abnehmbaren Kissen zu Auswahl.

ES Flexibilidad es la palabra clave de la colección Pikaia, diseñada por Angelo Natuzzi. El bastidor de poliuretano tiene un respaldo ergonómico particularmente elástico, ideal para sostener la espalda y adaptarse a la forma y al peso del cuerpo, mientras que las nervaduras de la base le confieren robustez y resistencia. La colección cuenta con numerosas versiones: la silla está disponible con patas, en versión apilable, con base de trineo o con ruedas, mientras que la butaca con brazos puede combinarse con patas o con ruedas. Adecuada tanto para los ambientes domésticos como para los colectivos, Pikaia está disponible en varios colores y con cojín extraíble, para aumentar su confort.

ES La flexibilité est le mot-clé de la collection Pikaia dessinée par Angelo Natuzzi. La coque en polyuréthane a un dossier ergonomique particulièrement élastique, idéal pour soutenir le dos et s'adapter à la forme et au poids du corps alors que les nervures à la base lui donnent robustesse et résistance. La collection propose de nombreuses versions: la chaise existe avec pieds, en version empilable, avec pieds luge ou avec roulettes, alors que le fauteuil avec accoudoirs s'associe à des pieds ou à des roulettes. Adaptée tant aux espaces domestiques que collectifs, Pikaia existe en divers coloris et avec coussin amovible pour un meilleur confort.

Type



Four legs - stackable
L 49 P 48 H 83
W 19^{1/8}" D 18^{7/8}" H 32^{5/8}"



Four legs with armrests - stackable
L 60 P 48 H 83 cm
W 23^{5/8}" D 18^{7/8}" H 32^{5/8}"



Slide frame - stackable
L 51 P 50 H 83 cm
W 20^{1/8}" D 19^{5/8}" H 32^{5/8}"



5-spoke base with castors
L 66 P 66 H 82/89 cm
W 26" D 26" H 32^{2/8}/35"



5-spoke base with castors and armrests
L 66 P 66 H 82/89 cm
W 26" D 26" H 32^{2/8}/35"



Lips—R
Removable cushion

Metal base

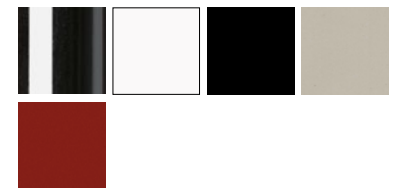

Polyurethane body





Face
Polyurethane body

Thin—K table
Aluminium top



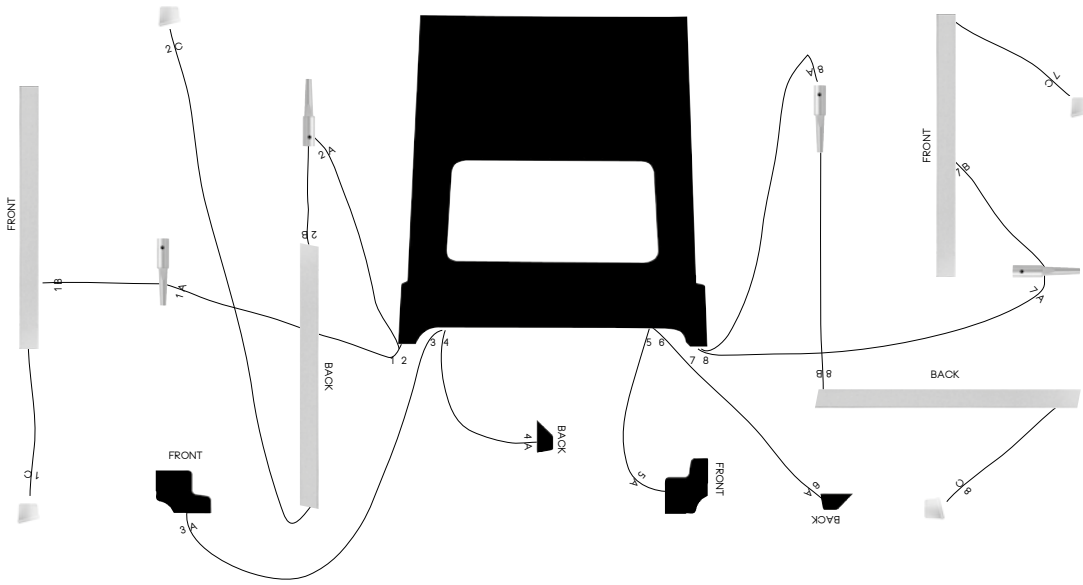

1



2

Soft options



Lips—R removable cushion

Face

DESIGN BY LUCA NICHETTO, 2005

I Sviluppata insieme al designer Luca Nichetto, la sedia Face è comoda e robusta. È realizzata in poliuretano, con scocca rinforzata per garantire resistenza alle sollecitazioni ed elasticità dello schienale. E proprio lo schienale – flessibile, adattabile al corpo e leggermente più alto della media – è l'elemento che rende la seduta confortevole. L'ampio foro facilita la presa della sedia, che è impilabile: caratteristiche che, unite alla spiccata personalità del design, la rendono ideale per gli ambienti collettivi, oltre che per quelli domestici.

EN Developed in collaboration with designer Luca Nichetto, the Face chair is comfortable and sturdy. It is made of polyurethane with a reinforced structure to ensure resistance to stress and the flexibility of the backrest. The backrest itself - flexible, adaptable to the body and slightly higher than average - is the element that makes the seat comfortable. The large hole makes it easier to grip the chair, which is stackable: combined with its highly distinctive design, such features make it ideal for community environments and for the home.

DE Der gemeinsam mit dem Designer Luca Nichetto entwickelte Stuhl Face ist bequem und robust. Er besteht aus Polyurethan mit verstärktem Aufbau, um Beanspruchungen standzuhalten und die Elastizität der Rückenlehne zu gewährleisten. Und genau diese flexible, der Körperform folgende und etwas

höhere Rückenlehne ist jenes Element, das dieses Sitzmöbel so komfortabel macht. Die große Öffnung erleichtert das Anheben des stapelbaren Stuhls. Alle diese Merkmale machen ihn gemeinsam mit der ausgeprägten Persönlichkeit des Designs zum idealen Sitzmöbel für Gemeinschaftseinrichtungen und für den häuslichen Bereich.

ES Desarrollada junto al diseñador Luca Nichetto, la silla Face es cómoda y robusta. Está realizada en poliuretano, con bastidor reforzado para garantizar su resistencia a las tensiones y la elasticidad del respaldo. Precisamente el respaldo –flexible, adaptable al cuerpo y ligeramente más alto que la media– es el elemento que asegura un extraordinario confort. Un amplio orificio facilita el agarre de la silla, que es apilable: características que, unidas a la marcada personalidad de su diseño, la convierten en una opción ideal para los ambientes colectivos o domésticos.

FR Développée avec le designer Luca Nichetto, la chaise Face est confortable et robuste. Elle est réalisée en polyuréthane, avec coque renforcée pour assurer la résistance aux sollicitations et l'élasticité du dossier. Et c'est justement le dossier – flexible, s'adaptant au corps et légèrement plus haut que la moyenne – qui donne le confort à cette chaise. La grande ouverture sur le dossier facilite la prise de cette chaise empilable : cette caractéristique ainsi

que la forte personnalité du design font qu'elle est idéale pour les espaces aussi bien collectifs que domestiques.

Sizes



Stackable chair

L 47 P 53 H 85 cm
W 18¹/₈" D 20⁷/₈" H 33¹/₈"



Lips—R
Removable cushion

Aluminium legs

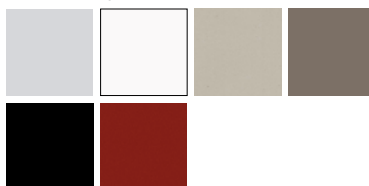

Polyurethane body

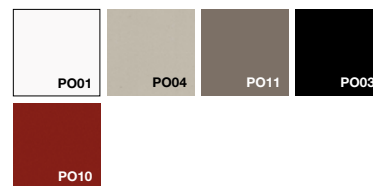



BCN stool - slide frame
PBT-plastic body





BCN stool - height adjustment
PBT-plastic body



BCN stool - wooden base
PBT-plastic body



1



Wooden base



Slide frame

DESIGN BY HARRY-PAUL, 2008

La ricerca nel campo del design si alimenta continuamente di forme, tecnologie e materiali nuovi. Lo sgabello BCN è l'esito di una di queste esplorazioni, condotta in collaborazione con il designer Harry-Paul. Tutto è partito da una forma, un sedile ergonomico e sinuoso. Quindi, la scelta di una tecnologia e di un materiale inusuali nel settore dell'arredamento: il PBT, una plastica robusta e flessibile allo stesso tempo. Nasce così uno dei nostri prodotti iconici, uno sgabello oggi disponibile in diverse versioni: alto, medio o basso con base a slitta, con gambe in legno di faggio o con fusto regolabile in altezza. Il sedile, così come le basi, è disponibile in vari colori.

Research in the field of design is constantly driven by new shapes, technologies and materials. The BCN stool is the result of one of these explorations, carried out in collaboration with the designer Harry-Paul. It all started with a shape, an ergonomic and sinuous seat, followed by choosing a technology and a material that are uncommon in the furniture sector: PBT, a plastic that is both strong and flexible. This led to one of our iconic products, a stool that is now available in various versions: high, medium or low with a slide-frame base, with beech wood legs or with a height-adjustable structure. The seat and the bases are available in a variety of colours.

Die Forschung auf dem Gebiet des Designs wird fortlaufend von Formen, Technologien und

neuen Materialien angetrieben. Der Hocker BCN ist das Ergebnis einer dieser zusammen mit dem Designer Harry-Paul durchgeführten Untersuchungen. Alles begann mit einer Form, einer ergonomischen und kurvig geformten Sitzfläche. Es folgte die Wahl einer Technologie und eines für den Einrichtungssektor ungewöhnlichen Materials: PBT, ein robuster und gleichzeitig flexibler Kunststoff. Und so entstand eines unserer legendären Produkte, ein Hocker, der heute in verschiedenen Versionen angeboten wird: hoch, mittel oder niedrig mit Kufengestell, mit Beinen aus Buchenholz oder mit höhenverstellbarem Aufbau. Die Sitzfläche und die Untergestelle sind in verschiedenen Farben lieferbar.

En el campo del diseño, la investigación se alimenta continuamente con nuevas formas, tecnologías y materiales. El taburete BCN es el resultado de una de estas exploraciones, realizada en colaboración con el diseñador Harry-Paul. Todo nace a partir de una forma, un asiento ergonómico y sinuoso. A continuación, la elección de una tecnología y de un material inusuales en el sector del mobiliario: el PBT, un plástico robusto y flexible al mismo tiempo. Nace así uno de nuestros productos icónicos, un taburete que hoy está disponible en distintas versiones: alto, mediano o bajo, con base de trineo, con patas de madera de haya o con armazón regulable en altura. El asiento, al igual que las bases, está disponible en varios colores.

La recherche dans le domaine du design s'alimente continuellement de formes, de technologies et de nouveaux matériaux. Le tabouret BCN est le résultat de l'une de ces explorations, conduite en collaboration avec le designer Harry-Paul. Tout est parti d'une forme, un siège ergonomique et sinueux. Puis le choix d'une technologie et d'un matériau inusuels dans le secteur du meuble : le PBT, une matière plastique à la fois robuste et flexible. D'où la naissance de l'un de nos produits iconiques, un tabouret aujourd'hui réalisé en diverses versions : haut, moyen et bas avec pieds luge, pieds en hêtre ou pied réglable en hauteur. L'assise et le piètement sont déclinés en divers coloris.

Type



Low stool on slide frame
L 41 P 40 H 63 cm
W 16 1/8" D 15 5/8" H 24 5/8"



Stool on slide frame
L 44 P 46 H 78-88 cm
W 17 3/8" D 18 1/8" H 30 5/8-34 5/8"



Stool on wooden base
L 54 P 52 H 78 cm
W 21 2/8" D 20 4/8" H 30 5/8"

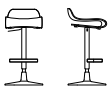

Stool with height adjustment
L 39 P 40 H 79/92 cm
W 15 3/8" D 15 5/8" H 31 1/8/36 2/8"

Metal base

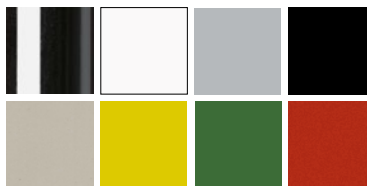

Beech base

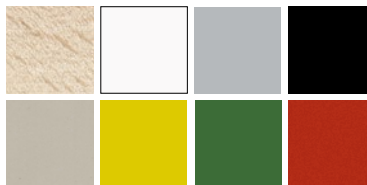

PBT-plastic body

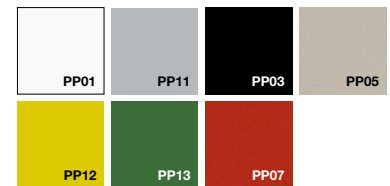



Holo table
Fenix-NTM® top

BCN table	210	Rotor	236
be—Easy	182	Sushi	152
Boiacca	170	Thin—K	144
Constellations	216	TNP	206
CU	232		
Degree	222		
Elephant table	194		
Font	226		
Holo	136		
Maki	164		
Neat	178		
Nori	158		
Oops/Oops IDIA	186		
Poule	200		



Holo table
Wooden top

Dua wooden legs armchair
Upholstered Regal velvet fabric

Dua wooden legs chair
Upholstered Steelcut Trio 3 fabric

Holo





Holo table
Wooden top

1085 Edition chair
Natural full-grain hide body



Holo table
Fenix-NTM® top

Joko chair
Upholstered Divina Melange 2 fabric



Holo console
Fenix-NTM® top



Holo occasional table
Transparent glass top



Production process



2

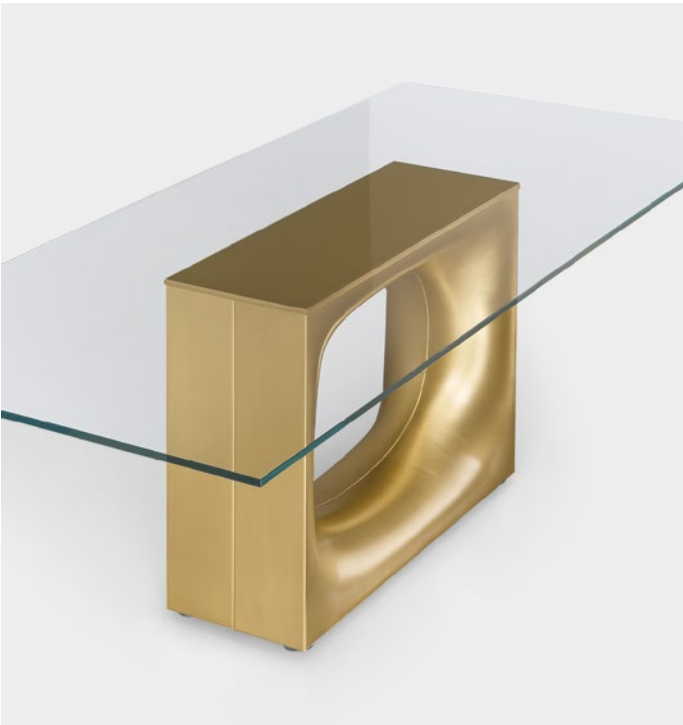

3



4

Type

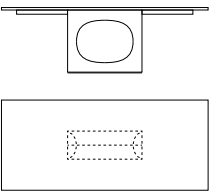

Table with central base
L 220 P 110 H 75 cm
W 86^{5/8}" D 43^{2/8}" H 29^{1/8}"
L 250 P 110 H 75 cm
W 98^{3/8}" D 43^{2/8}" H 29^{1/8}"
L 280 P 110 H 75 cm
W 110^{2/8}" D 43^{2/8}" H 29^{1/8}"

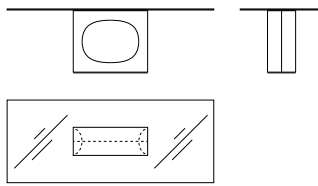

Table with central base - glass top
L 220 P 100 H 75 cm
W 86^{5/8}" D 39^{3/8}" H 29^{1/8}"
L 250 P 100 H 75 cm
W 98^{3/8}" D 39^{3/8}" H 29^{1/8}"

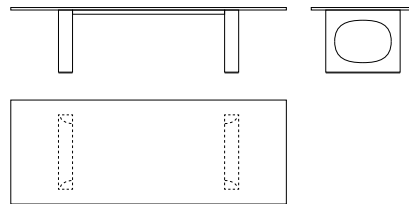

Table with double base
L 320 P 120 H 75 cm
W 126" D 47^{2/8}" H 29^{1/8}"
L 360 P 135 H 75 cm
W 141^{6/8}" D 53^{1/8}" H 29^{1/8}"

Holo

DESIGN BY KENSAKU OSHIRO, 2016

▣ Dall'incontro fra la tecnologia di Kristalia e la creatività di Kensaku Oshiro nasce Holo: un tavolo caratterizzato dall'inedita base con un foro ovale, dal contorno morbidamente plasmato, realizzata in lamiera di metallo con un processo che prevede numerosi passaggi di stampaggio e piegatura. Su questa originale e stabile base, proposta con varie finiture, è appoggiato un piano in Fenix-NTM®, vetro oppure in legno massello. Tre diverse possibilità per un elemento d'arredo dalla personalità davvero unica. La collezione Holo arricchisce ulteriormente la propria gamma e presenta il nuovo tavolino e la consolle, completamente ideale per un unico e raffinato spazio living.

EN **The combination of Kristalia's technology with Kensaku Oshiro's creativity has led to Holo: a table featuring an original base and an oval hole, with a softly moulded shape in sheet metal, made using a process that involves many moulding and bending phases. This original and stable base, available in various finishes, supports Fenix-NTM®, glass or solid wood top. Three options are available for this furnishing object with a truly unique personality. The Holo collection further enhances the range and includes a new occasional table and console table, the perfect finishing touch for a unique and refined living space.**

DE Aus dem Treffen zwischen der Technologie Kristalia und der Kreativität von Kensaku Oshiro

entsteht Holo: Ein Tisch, der sich durch sein ungewöhnliches Untergestell mit einem ovalen Loch und weich modellierten Linien auszeichnet, das mit einem besonderen Prozess mit zahlreichen Spritzguss- und Biegedurchgängen aus Metallblech hergestellt wird. Auf diesem originellen, stabilen und in mehrere Ausführungen angebotenen Untergestell ruht eine Platte aus Fenix-NTM®, Glas oder aus massivem Holz. Drei verschiedene Möglichkeiten für ein Einrichtungselement mit wirklich einzigartiger Persönlichkeit. Die Kollektion Holo erweitert ihr Produktangebot und präsentiert den neuen Beistelltisch und die Tischkonsole, das ideale Einrichtungselement für einen einzigartigen und raffinierten Wohnraum.

ES Del encuentro entre la tecnología de Kristalia y la creatividad de Kensaku Oshiro nace Holo: una mesa caracterizada por una base inédita con un orificio oval, de contorno suavemente plasmado, realizada en chapa de metal con un proceso que abarca numerosas fases de moldeado y pliegue. Sobre esta base estable y original, propuesta en varios acabados, apoya un sobre de Fenix-NTM®, vidrio o madera maciza. Tres posibilidades distintas en un elemento decorativo con una personalidad realmente única. La colección Holo enriquece su gama presentando una nueva mesita y una consola, complementos ideales en una exclusiva y refinada sala de estar.

FR L'alliance entre la technologie Kristalia et la créativité de Kensaku Oshiro a engendré Holo:

una table se caractérisant par un piètement inédit doté d'une ouverture ovale avec un contour délicatement modelé, réalisé en tôle métallique grâce à un procédé de fabrication prévoyant de nombreuses étapes de moulage et de pliage. C'est sur ce piètement original et stable, proposé en différentes finitions, que repose le plateau décliné en Fenix-NTM®, en verre ou bien en bois massif: trois différentes solutions pour cet élément décoratif à la personnalité vraiment unique. La collection Holo enrichit encore sa propre gamme avec deux nouveautés: une table basse et une console pour compléter l'espace séjour de façon unique et raffinée.

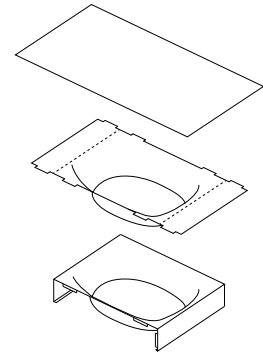

Type

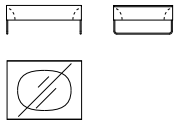

Occasional table
L 90 P 71 H 36 cm
W 35^{3/8}" D 28" H 14^{1/8}"

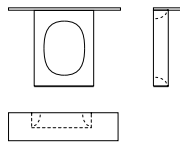

Console table
L 140 P 35 H 94 cm
W 55^{1/8}" D 13^{5/8}" H 37"

Steel base



Brass base



Fenix-NTM® top



Wood top

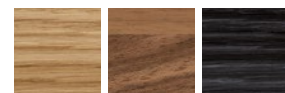

Transparent glass top



Not all finishes are available in sizes listed. Refer to current price list.



Thin—K



Thin—K table
Aluminium top

Face
Polyurethane body

Lips—R removable cushion
Upholstered Field 2 fabric



Thin—K table
Wooden top

Joko chair
Upholstered Divina Melange 2 fabric





Thin—K table
Wooden top

Elephant wooden base armchair
Polyurethane body



Thin—K table
Aluminium top

1085 Edition chair
Black full-grain hide body

Sharky chair - aluminium base
Polyurethane body



Luciano Bertoncini



2



3



4

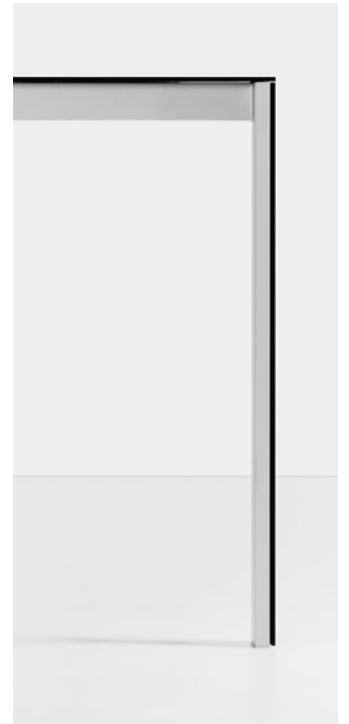

5

DESIGN BY LUCIANO BERTONCINI, 2011

Prima di essere un tavolo, Thin-K è una sfida tecnologica e formale. Ai limiti del minimalismo assoluto, il piano di Thin-K è spesso appena 6 mm e può raggiungere lunghezze considerevoli senza perdere linearità e solidità, sottile al punto da sembrare sospeso in aria. Disegnato da Luciano Bertocini, Thin-K è realizzato totalmente in metallo, con particolari esterni delle gambe e piano in alluminio, vetro lucido o opaco e alluminio impiallacciato in essenza – materiali resistenti, duraturi e completamente riciclabili. La finitura gofrata del piano in alluminio lo rende liscio e piacevole al tatto. Fisso o allungabile, il tavolo Thin-K è disponibile in diversi colori.

Thin-K can be considered more of a technological and formal challenge than a table. At the limits of sheer minimalism, the top of Thin-K is just 6mm thick and can extend to considerable lengths without losing its linearity and sturdiness. It is narrow enough to appear suspended in the air. Designed by Luciano Bertocini, Thin-K is made entirely of metal, with external leg details and a top in aluminium, gloss or matt glass, and wood veneered aluminium - resistant, durable and completely recyclable materials. The textured finish of the aluminium top makes it smooth and pleasant to the touch. Fixed or extendable, the Thin-K table is available in various colours.

Bevor er ein Tisch wurde, war Thin-K vor allem eine technologische und formale

Herausforderung. An der Grenze des absoluten Minimalismus ist die Platte von Thin-K Top knappe 6 mm dick und kann beträchtliche Längen erreichen, ohne dabei an Linearität und Stärke zu verlieren, so dünn, um scheinbar in der Luft zu schweben. Der Tisch Thin-K nach einem Entwurf von Luciano Bertocini wird ganz aus Metall hergestellt, mit außenliegenden Details und Platte aus Aluminium, glänzendem oder mattem Glas oder aus Aluminium mit Holz furnier – alles widerstandsfähige, langlebige und vollständig recycelbare Materialien. Die leicht strukturierte Ausführung der Platte aus Aluminium machen diese angenehm glatt und berührungsfreundlich. Der fixe oder verlängerbare Tisch Thin-K steht in verschiedenen Farben zur Auswahl.

Más que una mesa, Thin-K es un desafío tecnológico y formal. Al límite del minimalismo absoluto, el sobre de Thin-K tiene un espesor de tan solo 6 mm y puede alcanzar longitudes considerables sin perder su linealidad y solidez, tan fino que parece suspendido en el aire. Diseñada por Luciano Bertocini, Thin-K está realizada totalmente en metal, con los detalles externos de las patas y el sobre de aluminio, cristal brillante o mate y aluminio chapado en madera: materiales resistentes, duraderos y completamente reciclables. El acabado gofrado del sobre de aluminio le confiere un aspecto liso y un tacto agradable. Fija o extensible, la mesa Thin-K está disponible en varios colores.

Avant d'être une table, Thin-K est un défi technologique et formel. Se distinguant par un minimalisme quasi absolu, le plateau de Thin-K n'a qu'une épaisseur d'à peine 6 mm et peut atteindre des grandes dimensions sans jamais fléchir ni perdre sa solidité. Il est si fin qu'il semble suspendu en l'air. Dessinée par Luciano Bertocini, Thin-K est entièrement réalisée en métal, avec face extérieure des pieds et plateau en aluminium, en verre brillant ou mat ou en aluminium plaqué bois – des matériaux résistants, durables et totalement recyclables. Le plateau en aluminium finition satinée est lisse et agréable au toucher. Fixe ou à rallonges, la table Thin-K existe en divers coloris au choix.

Sizes

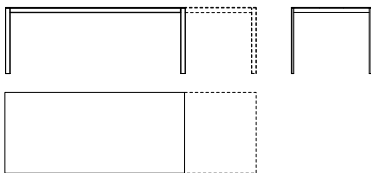

L 80 P 80 H 75 cm W 31 ¹ / ₈ " D 31 ¹ / ₈ " H 29 ¹ / ₈ "	L 260 P 100 H 075 cm W 102 ³ / ₈ " D 39 ³ / ₈ " H 29 ¹ / ₈ "
L 123/203 P 80 H 75 cm W 48 ³ / ₈ /79" D 31 ¹ / ₈ " H 29 ¹ / ₈ "	L 280 P 100 H 75 cm W 110 ² / ₈ " D 39 ³ / ₈ " H 29 ¹ / ₈ "
L 150/230 P 80 H 75 cm W 59/90 ¹ / ₂ " D 31 ¹ / ₈ " H 29 ¹ / ₈ "	L 295 P 100 H 75 cm W 116 ¹ / ₈ " D 39 ³ / ₈ " H 29 ¹ / ₈ "
L 150/230 P 90 H 75 cm W 59/90 ¹ / ₂ " D 35 ³ / ₈ " H 29 ¹ / ₈ "	L 240 P 120 H 75 cm W 94 ¹ / ₈ " D 47 ² / ₈ " H 29 ¹ / ₈ "
L 170/250 P 90 H 75 cm W 66 ⁷ / ₈ /98 ³ / ₈ " D 35 ³ / ₈ "	L 260 P 120 H 75 cm W 102 ³ / ₈ " D 47 ² / ₈ " H 29 ¹ / ₈ "
L 200/280 P 100 H 75 cm W 78 ³ / ₄ /110 ² / ₈ " D 39 ³ / ₈ "	L 280 P 120 H 75 cm W 110 ² / ₈ " D 47 ² / ₈ " H 29 ¹ / ₈ "
L 220 P 100 H 75 cm W 86 ⁵ / ₈ " D 39 ³ / ₈ " H 29 ¹ / ₈ "	L 295 P 120 H 75 cm W 116 ¹ / ₈ " D 47 ² / ₈ " H 29 ¹ / ₈ "
L 240 P 100 H 75 cm W 94 ¹ / ₈ " D 39 ³ / ₈ " H 29 ¹ / ₈ "	

Steel legs

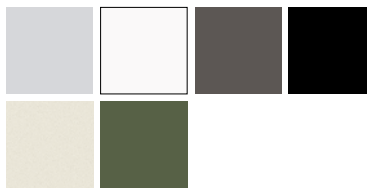

Aluminium top/external details on leg

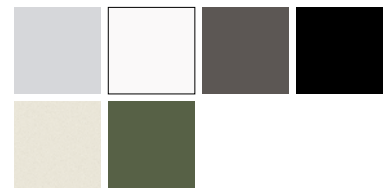

Wood top/external details on leg

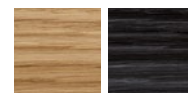

Gloss or matt glass top/external details on leg



Not all finishes are available in sizes listed. Refer to current price list.



Sushi



Sushi table
Fenix-NTM® top

1085 Edition chair
Natural /black full-grain hide body





Sushi trolley
Alucompact® laminate top

Degree occasional table
Cork



1



2



3

Sizes

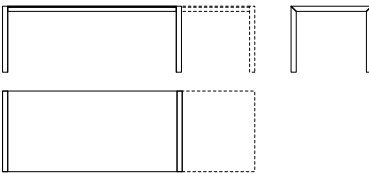

L 125 P 55 H 75 cm W 49 ² / ₈ " D 21 ⁵ / ₈ " H 29 ⁴ / ₈ "	L 240 P 80 H 75 cm W 94 ⁴ / ₈ " D 31 ⁴ / ₈ " H 29 ⁴ / ₈ "	L 220/294 P 90 H 75 cm W 86 ⁵ / ₈ "/116 ¹ / ₈ " D 35 ³ / ₈ "	L 220/314 P 100 H 75 cm W 86 ⁵ / ₈ "/123 ³ / ₄ " D 39 ³ / ₈ "
L 147 P 55 H 75 cm W 57 ⁷ / ₈ " D 21 ⁵ / ₈ " H 29 ⁴ / ₈ "	L 260 P 80 H 75 cm W 102 ³ / ₈ " D 31 ⁴ / ₈ " H 29 ⁴ / ₈ "	L 240 P 90 H 75 cm W 94 ⁴ / ₈ " D 35 ³ / ₈ " H 29 ⁴ / ₈ "	L 240 P 100 H 75 cm W 94 ⁴ / ₈ " D 39 ³ / ₈ " H 29 ⁴ / ₈ "
L 216 P 55 H 75 cm W 85" D 21 ⁵ / ₈ " H 29 ⁴ / ₈ "	L 280 P 80 H 75 cm W 110 ² / ₈ " D 31 ⁴ / ₈ " H 29 ⁴ / ₈ "	L 260 P 90 H 75 cm W 102 ³ / ₈ " D 35 ³ / ₈ " H 29 ⁴ / ₈ "	L 260 P 100 H 75 cm W 102 ³ / ₈ " D 39 ³ / ₈ " H 29 ⁴ / ₈ "
L 80 P 80 H 75 cm W 31 ⁴ / ₈ " D 31 ⁴ / ₈ " H 29 ⁴ / ₈ "	L 300 P 80 H 75 cm W 118 ¹ / ₈ " D 31 ⁴ / ₈ " H 29 ⁴ / ₈ "	L 280 P 90 H 75 cm W 110 ² / ₈ " D 35 ³ / ₈ " H 29 ⁴ / ₈ "	L 280 P 100 H 75 cm W 110 ² / ₈ " D 39 ³ / ₈ " H 29 ⁴ / ₈ "
L 125/205 P 80 H 75 cm W 49 ² / ₈ "/80 ³ / ₄ " D 31 ⁴ / ₈ "	L 90 P 90 H 75 cm W 35 ³ / ₈ " D 35 ³ / ₈ " H 29 ⁴ / ₈ "	L 300 P 90 H 75 cm W 118 ¹ / ₈ " D 35 ³ / ₈ " H 29 ⁴ / ₈ "	L 300 P 100 H 75 cm W 118 ¹ / ₈ " D 39 ³ / ₈ " H 29 ⁴ / ₈ "
L 150/230 P 80 H 75 cm W 59 ⁹ / ₄ " D 31 ⁴ / ₈ "	L 125 P 90 H 75 cm W 49 ² / ₈ " D 35 ³ / ₈ " H 29 ⁴ / ₈ "	L 100/170 P 100 H 75 cm W 39 ³ / ₈ "/67" D 39 ³ / ₈ "	L 220 P 124 H 75 cm W 86 ⁵ / ₈ " D 48 ⁷ / ₈ " H 29 ⁴ / ₈ "
L 177/257 P 80 H 75 cm W 69 ³ / ₄ "/101 ² / ₈ " D 31 ⁴ / ₈ "	L 150/224 P 90 H 75 cm W 59 ⁸ / ₈ "/82 ⁷ / ₈ " D 35 ³ / ₈ "	L 150 P 100 H 75 cm W 59" D 39 ³ / ₈ " H 29 ⁴ / ₈ "	L 240 P 124 H 75 cm W 94 ⁴ / ₈ " D 48 ⁷ / ₈ " H 29 ⁴ / ₈ "
L 200 P 80 H 75 cm W 78 ³ / ₄ " D 31 ⁴ / ₈ " H 29 ⁴ / ₈ "	L 177/288 P 90 H 75 cm W 69 ³ / ₄ "/113 ³ / ₈ " D 35 ³ / ₈ "	L 177/271 P 100 H 75 cm W 69 ³ / ₄ "/106 ³ / ₄ " D 39 ³ / ₈ "	L 288 P 124 H 75 cm W 113 ³ / ₈ " D 48 ⁷ / ₈ " H 29 ⁴ / ₈ "
L 220 P 80 H 75 cm W 86 ⁵ / ₈ " D 31 ⁴ / ₈ " H 29 ⁴ / ₈ "	L 200/274 P 90 H 75 cm W 78 ³ / ₄ "/107 ⁷ / ₈ " D 35 ³ / ₈ "	L 200/294 P 100 H 75 cm W 78 ³ / ₄ "/115 ³ / ₄ " D 39 ³ / ₈ "	L 140 P 140 H 75 cm W 55 ¹ / ₈ " D 55 ¹ / ₈ " H 29 ⁴ / ₈ "



4

DESIGN BY BARTOLI DESIGN, 2002

IT Bellezza, tecnologia, innovazione: Sushi è una filosofia d'arredo tradotta in forma di tavolo. Disegnato da Bartoli Design, il nostro tavolo best seller è un compendio della nostra poetica, a partire dalla sua forma essenziale per arrivare ai materiali di ricerca scelti per il piano, dai laminati Alucompact® e Pure-white al Fenix-NTM®, dal DEKTON® by Cosentino al vetro. La struttura e le gambe, in trafilata di alluminio anodizzato 6x6 cm, possono essere a contrasto o verniciate nella stessa tonalità del piano. Fisso o allungabile, Sushi è nato nel 2002 e da allora viene costantemente aggiornato nelle finiture e nelle dimensioni, continuando a essere, anno dopo anno, il nostro tavolo più amato.

EN Beauty, technology and innovation: Sushi is a furnishing philosophy expressed in the shape of a table. Designed by Bartoli Design, our best-selling table sums up our poetic nature with its minimalist shape and sophisticated materials chosen for the top, including Alucompact® and Pure-white laminates, Fenix-NTM®, DEKTON® by Cosentino, and glass. The frame and legs, made of 6x6cm drawn anodized aluminium are available in a contrasting colour or can be painted in the same colour as the top. Available in a fixed or extendable version, Sushi was created in 2002 and since then it has been constantly updated in its finishes and sizes, continuing to be our most popular table year after year.

DE Schönheit, Technologie, Innovation: Sushi ist eine Einrichtungsphilosophie, die in Form eines Tisches umgesetzt wird. Der von Bartoli Design entworfene Bestseller unter unseren Tischen ist ein Gesamtausdruck unserer Poetik, ausgehend von seiner essenziellen Form bis hin zu den für die Platte ausgewählten Forschungsmaterialien wie Laminate Alucompact® und Pure-white, Fenix-NTM® sowie DEKTON® by Cosentino und Glas. Die Struktur und die Beine aus eloxiertem stranggepresstem Aluminium 6x6 cm können in Kontrastfarbe oder lackiert im Farbton der Platte gewählt werden. Der fixe oder verlängerbare Tisch Sushi entstand bereits im Jahr 2002 und wurde seither ständig in seinen Ausführungen und Größen aktualisiert, weshalb er Jahr für Jahr unser beliebtestes Tischmodell ist.

ES Belleza, tecnología e innovación: Sushi es una filosofía decorativa traducida en forma de mesa. Diseñada por Bartoli Design, nuestra mesa superventas es un compendio de nuestra poética, gracias a su forma esencial y a los innovadores materiales seleccionados para el sobre: de los laminados Alucompact® y Pure-white al Fenix-NTM®, el DEKTON® by Cosentino o el cristal. La estructura y las patas, de aluminio trefilado anodizado 6 x 6 cm, pueden realizarse en contraste o barnizadas en el mismo tono que el sobre. Actualizada constantemente desde su creación en 2002 en sus acabados y sus dimensiones, esta mesa fija o extensible sigue siendo nuestro modelo preferido año tras año.

FR Beauté, technologie, innovation : Sushi est une philosophie de meubles traduite sous forme de table. Dessinée par Bartoli Design, notre table best-seller est un résumé de notre poétique, à commencer par sa forme épurée jusqu'aux matériaux de recherche choisis pour le plateau, allant des stratifiés Alucompact® et Pure-white jusqu'au Fenix-NTM®, au DEKTON® by Cosentino et au verre. La structure et les pieds, en aluminium tréfilé anodisé de 6x6 cm, peuvent être contrastants ou laqués dans la même tonalité que le plateau. Fixe ou à rallonges, Sushi a été créée en 2002 et, depuis lors, elle a constamment été renouvelée dans les finitions et les dimensions, en continuant à être, d'année en année, notre table la plus aimée.

Aluminium legs



Alucompact® laminate top



Pure-white laminate top



Fenix-NTM® black edge top



Fenix-NTM® coloured edge top



DEKTON® by Cosentino top



Gloss or matt glass top



Not all finishes are available in sizes listed. Refer to current price list.



Nori



Nori table
Pure-white laminate top

Mem armchair
Polypropylene

Lips—D removable cushion
Upholstered Field 2 fabric



Nori table
Matt glass top



Nori table
Pure-white laminate top

Joko chair
Upholstered Divina Melange 2 fabric



1



2



3

Sizes

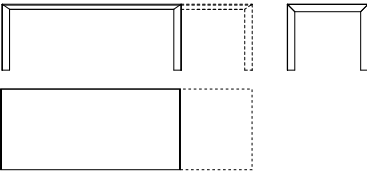

L 114/194 P 80 H 75 cm W 44 ^{7/8} D 76 ^{3/8} D 31 ^{1/8}	L 289 P 80 H 75 cm W 113 ^{5/8} D 31 ^{1/8} H 29 ^{1/8}	L 269 P 90 H 75 cm W 105 ^{7/8} D 35 ^{3/8} H 29 ^{1/8}	L 269 P 100 H 75 cm W 105 ^{7/8} D 39 ^{3/8} H 29 ^{1/8}
L 139/219 P 80 H 75 cm W 54 ^{3/8} D 86 ^{2/8} D 31 ^{1/8}	L 114 P 90 H 75 cm W 44 ^{7/8} D 35 ^{3/8} H 29 ^{1/8}	L 289 P 90 H 75 cm W 113 ^{5/8} D 35 ^{3/8} H 29 ^{1/8}	L 289 P 100 H 75 cm W 113 ^{5/8} D 39 ^{3/8} H 29 ^{1/8}
L 166/246 P 80 H 75 cm W 65 ^{3/8} D 96 ^{7/8} D 31 ^{1/8}	L 139/214 P 90 H 75 cm W 54 ^{3/8} D 84 ^{2/8} D 35 ^{3/8}	L 139 P 100 H 75 cm W 54 ^{3/8} D 39 ^{3/8} H 29 ^{1/8}	L 209 P 124 H 75 cm W 82 ^{2/8} D 48 ^{7/8} H 29 ^{1/8}
L 189 P 80 H 75 cm W 74 ^{3/8} D 31 ^{1/8} H 29 ^{1/8}	L 166/278 P 90 H 75 cm W 65 ^{3/8} D 109 ^{4/8} D 35 ^{3/8}	L 166/260 P 100 H 75 cm W 65 ^{3/8} D 102 ^{3/8} D 39 ^{3/8}	L 229 P 124 H 75 cm W 90 ^{1/8} D 48 ^{7/8} H 29 ^{1/8}
L 209 P 80 H 75 cm W 82 ^{2/8} D 31 ^{1/8} H 29 ^{1/8}	L 189/263 P 90 H 75 cm W 74 ^{3/8} D 103 ^{4/8} D 35 ^{3/8}	L 189/283 P 100 H 75 cm W 74 ^{3/8} D 111 ^{3/8} D 39 ^{3/8}	L 277 P 124 H 75 cm W 109 D 48 ^{7/8} H 29 ^{1/8}
L 229 P 80 H 75 cm W 90 ^{1/8} D 31 ^{1/8} H 29 ^{1/8}	L 209/283 P 90 H 75 cm W 82 ^{2/8} D 111 ^{3/8} D 35 ^{3/8}	L 209/303 P 100 H 75 cm W 82 ^{2/8} D 119 ^{2/8} D 39 ^{3/8}	
L 249 P 80 H 75 cm W 98 D 31 ^{1/8} H 29 ^{1/8}	L 229 P 90 H 75 cm W 90 ^{1/8} D 35 ^{3/8} H 29 ^{1/8}	L 229 P 100 H 75 cm W 90 ^{1/8} D 39 ^{3/8} H 29 ^{1/8}	
L 269 P 80 H 75 cm W 105 ^{7/8} D 31 ^{1/8} H 29 ^{1/8}	L 249 P 90 H 75 cm W 98 D 35 ^{3/8} H 29 ^{1/8}	L 249 P 100 H 75 cm W 98 D 39 ^{3/8} H 29 ^{1/8}	



Leg section scale 1:1

Nori

DESIGN BY BARTOLI DESIGN, 2008

II Evoluzione di Sushi, anche Nori è un tavolo fisso o allungabile disponibile in un'ampia gamma di dimensioni e finiture. Cambia, in Nori, il disegno delle gambe, che con la loro sezione affilata lo rendono più dinamico. Il piano, realizzato con materiali all'avanguardia come i laminati Alucompact® e Pure-white, il Fenix-NTM®, il DEKTON® by Cosentino, il vetro lucido o opaco, è sottile ma molto resistente. Per la qualità del progetto e la complessa tecnologia di realizzazione, i tavoli Nori possono raggiungere dimensioni considerevoli senza perdere leggerezza e stabilità.

EN **An evolution of Sushi, Nori is also a fixed or extendable table available in a wide range of sizes and finishes. But Nori has a different design for its legs, which have a sharp cross-section that gives them a more dynamic look. The top, made of cutting-edge materials such as Alucompact® and Pure-white laminates, Fenix-NTM®, DEKTON® by Cosentino, and gloss or matt glass, is narrow yet highly resistant. Thanks to the quality design project and the complex technology used, Nori tables are also available in large sizes without losing their lightness and stability.**

DE Auch Nori, eine Evolution von Sushi, ist ein fixer oder verlängerbarer Tisch mit einer großen Auswahl von Größen und Ausführungen. Bei Nori ändert sich der Entwurf der Beine, die das Modell mit ihrem scharfen Querschnitt noch

dynamischer machen. Die dünne, aber sehr widerstandsfähige Platte ist aus fortschrittlichen Materialien gefertigt, wie die Laminat Alucompact® und Pure-white, Fenix-NTM®, DEKTON® by Cosentino, glänzendes oder mattes Glas. Aufgrund der Qualität des Projekts und der bei der Realisierung eingesetzten komplexen Technologie können die Tische Nori bemerkenswerte Größen erreichen, ohne dabei etwas von ihrer Leichtigkeit oder Stabilität einzubüßen.

ES Evolución de Sushi, Nori es también una mesa fija o extensible, disponible en una amplia gama de dimensiones y acabados. En Nori cambia el diseño de las patas, que con su sección afilada le confieren un carácter más dinámico. Fino pero muy resistente, el sobre está realizado con materiales de vanguardia como los laminados Alucompact® y Pure-white, el Fenix-NTM®, el DEKTON® by Cosentino o el cristal brillante o mate. Gracias a la calidad del proyecto y a la compleja tecnología aplicada en su realización, las mesas Nori pueden alcanzar dimensiones considerables sin perder su ligereza o estabilidad.

FR Évolution de Sushi, Nori est elle aussi une table fixe ou à rallonges déclinée dans une vaste gamme de dimensions et de finitions. Ce qui change avec ce modèle, c'est le dessin des pieds qui, avec leur coupe effilée, la rendent plus dynamique. Le plateau, réalisé avec des matériaux avant-gardistes comme les stratifiés

Alucompact® et Pure-white, le Fenix-NTM®, le DEKTON® by Cosentino, le verre brillant ou mat, est à la fois fin et résistant. De par la qualité du projet et la technologie de réalisation complexe, les tables Nori peuvent atteindre de grandes dimensions sans jamais perdre leur légèreté ni leur stabilité.

Aluminium legs



Alucompact® laminate top



Pure-white laminate top



Fenix-NTM® black edge top



Fenix-NTM® coloured edge top



DEKTON® by Cosentino top



Gloss or matt glass top



Not all finishes are available in sizes listed. Refer to current price list.



Maki table
Fenix-NTM® top

Joko chair
Upholstered Steelcut Trio 3 fabric/Elmosoft leather

Maki





Maki table
DEKTON® top



Maki table
Pure-white laminate top

Sharky chair - wooden base
Frontal upholstered Steelcut Trio 3 fabric



1



2



3

Sizes

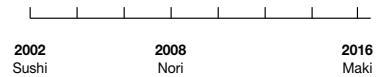
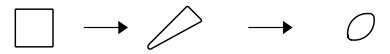
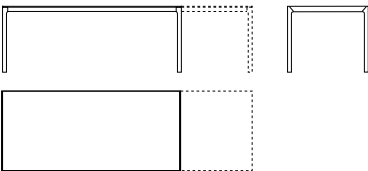

L 114/194 P 80 H 75 cm W 44 ⁷ / ₈ D 31 ⁴ / ₈ "	L 289 P 80 H 75 cm W 113 ⁶ / ₈ D 31 ⁴ / ₈ H 29 ⁴ / ₈ "	L 269 P 90 H 75 cm W 105 ⁷ / ₈ D 35 ³ / ₈ H 29 ⁴ / ₈ "	L 269 P 100 H 75 cm W 105 ⁷ / ₈ D 39 ³ / ₈ H 29 ⁴ / ₈ "
L 139/219 P 80 H 75 cm W 54 ⁶ / ₈ D 31 ⁴ / ₈ "	L 114 P 90 H 75 cm W 44 ⁷ / ₈ D 35 ³ / ₈ H 29 ⁴ / ₈ "	L 289 P 90 H 75 cm W 113 ⁶ / ₈ D 35 ³ / ₈ H 29 ⁴ / ₈ "	L 289 P 100 H 75 cm W 113 ⁶ / ₈ D 39 ³ / ₈ H 29 ⁴ / ₈ "
L 166/246 P 80 H 75 cm W 65 ³ / ₈ D 31 ⁴ / ₈ "	L 139/214 P 90 H 75 cm W 54 ⁶ / ₈ D 35 ³ / ₈ "	L 139 P 100 H 75 cm W 54 ⁶ / ₈ D 39 ³ / ₈ H 29 ⁴ / ₈ "	L 209 P 124 H 75 cm W 82 ² / ₈ D 48 ⁷ / ₈ H 29 ⁴ / ₈ "
L 189 P 80 H 75 cm W 74 ³ / ₈ D 31 ⁴ / ₈ "	L 166/278 P 90 H 75 cm W 65 ³ / ₈ D 35 ³ / ₈ "	L 166/260 P 100 H 75 cm W 65 ³ / ₈ D 39 ³ / ₈ "	L 229 P 124 H 75 cm W 90 ¹ / ₈ D 48 ⁷ / ₈ H 29 ⁴ / ₈ "
L 209 P 80 H 75 cm W 82 ² / ₈ D 31 ⁴ / ₈ "	L 189/263 P 90 H 75 cm W 74 ³ / ₈ D 35 ³ / ₈ "	L 189/283 P 100 H 75 cm W 74 ³ / ₈ D 39 ³ / ₈ "	L 277 P 124 H 75 cm W 109 D 48 ⁷ / ₈ H 29 ⁴ / ₈ "
L 229 P 80 H 75 cm W 90 ¹ / ₈ D 31 ⁴ / ₈ "	L 209/283 P 90 H 75 cm W 82 ² / ₈ D 35 ³ / ₈ "	L 209/303 P 100 H 75 cm W 82 ² / ₈ D 39 ³ / ₈ "	
L 249 P 80 H 75 cm W 98 D 31 ⁴ / ₈ "	L 229 P 90 H 75 cm W 90 ¹ / ₈ D 35 ³ / ₈ "	L 229 P 100 H 75 cm W 90 ¹ / ₈ D 39 ³ / ₈ "	
L 269 P 80 H 75 cm W 105 ⁷ / ₈ D 31 ⁴ / ₈ "	L 249 P 90 H 75 cm W 98 D 35 ³ / ₈ "	L 249 P 100 H 75 cm W 98 D 39 ³ / ₈ "	

Maki

DESIGN BY BARTOLI DESIGN, 2016

□ Dalla matita di Bartoli Design sono nati in passato i nostri best seller Sushi e Nori. Maki è l'ultimo progetto – in ordine di tempo – realizzato in collaborazione con questo storico studio italiano, un tavolo ispirato ancora una volta a un'idea di assoluta essenzialità di gusto orientale, nel quale però i profili delle gambe e del piano assumono contorni morbidi e arrotondati. Maki è disponibile in molte dimensioni e varianti di colore, per dare forma a infinite possibilità estetiche e d'uso. Le gambe sono in pressofusione di alluminio, mentre il piano è disponibile nei laminati Alucompact® e Pure-white e in Fenix-NTM®, DEKTON® by Cosentino, vetro lucido o opaco.

EN **Bartoli Design designed and created our best sellers, Sushi and Nori. Maki is the latest design project – in chronological order – the result of a partnership with this long-standing studio in Italy: a table inspired, once again, by the sheer simplicity of oriental style, in which the leg and top profiles feature smooth rounded edges. Maki is available in a variety of sizes and colours, allowing a multitude of aesthetic and functional solutions. The legs are made of die-cast aluminium, whereas the top is available in Alucompact® and Pure-white laminates, Fenix-NTM®, DEKTON® by Cosentino, and gloss or matt glass.**

DE Den Bleistiftskizzen von Bartoli Design sind in der Vergangenheit unsere Bestseller Sushi

und Nori entsprungen. Maki ist in zeitlicher Reihenfolge das jüngste Projekt in Zusammenarbeit mit diesem historischen italienischen Studio, ein Tisch, der erneut von einer Idee der absoluten Wesentlichkeit des orientalischen Geschmacks inspiriert ist, bei dem die Profile der Beine und der Platte jedoch weiche und abgerundete Konturen annehmen. Maki ist in vielen Größen und Farbvarianten erhältlich, um unzählige Versionen in Sachen Ästhetik und Gebrauch zu ermöglichen. Die Beine bestehen aus Aluguss, die Platte ist hingegen in den Laminaten Alucompact® und Pure-white, in Fenix-NTM®, DEKTON® by Cosentino sowie glänzendem oder mattem Glas erhältlich.

ES Del lápiz de Bartoli Design han nacido en el pasado nuestros superventas Sushi y Nori. Maki es el último proyecto –en orden temporal– realizado en colaboración con este histórico estudio italiano, una mesa inspirada una vez más en una idea de total esencialidad de gusto oriental, pero en la que los perfiles de las patas y del sobre asumen contornos suaves y redondeados. Maki está disponible en numerosos tamaños y variantes de color, para dar forma a infinitas posibilidades estéticas y de uso. Las patas son de aluminio moldeado bajo presión, mientras que el sobre está disponible en los laminados Alucompact® y Pure-white y en Fenix-NTM®, DEKTON® by Cosentino y cristal brillante o mate.

FR Le crayon de Bartoli Design a donné naissance, par le passé, à nos best-sellers Sushi et Nori. Maki est le dernier projet – dans l'ordre chronologique – réalisé en collaboration avec cette historique agence italienne : une table s'inspirant encore une fois d'une ligne absolument épurée au goût oriental, où les profils des pieds et du plateau ont cependant des contours doux et arrondis. Maki existe dans de nombreuses dimensions et tonalités, pour donner vie à une infinité de possibilités esthétiques et d'emploi. Les pieds sont en aluminium moulé sous pression alors que le plateau existe en stratifié Alucompact® ou Pure-white et en Fenix-NTM®, en DEKTON® by Cosentino, en verre brillant ou mat.

Aluminium legs

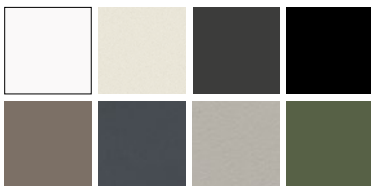

Alucompact® laminate top



Pure-white laminate top



Fenix-NTM® black edge top



Fenix-NTM® coloured edge top



DEKTON® by Cosentino top



Gloss or matt glass top



Not all finishes are available in sizes listed. Refer to current price list.



Boiacca table
Cement version

Joko armchair
Upholstered Divina MD fabric

Boiaccia





Boiacca table
Cement version





Boiacca table
Wood version

Rama chair - four wood legs
Frontal upholstered Hero fabric

Degree occasional table
Cork





1



2



Production process



4

Boiaccia

DESIGN BY LUCIDIPEVERE, 2011

▣ Disegnato da LucidiPevere nel 2011, Boiaccia è nato come una sfida: creare un tavolo usando un materiale grezzo e imperfetto come il cemento. Il risultato è un tavolo raffinato e poetico capace di regalare sensazioni tattili e visive particolari, menzione d'onore al Compasso d'Oro 2014. In seguito, il tavolo Boiaccia è stato declinato in una forma più tradizionale, con piano in laminato Pure-white o Fenix-NTM® e gambe in legno con anima in metallo – una realizzazione di alta qualità tecnica e artigianale. Ancora attualissima, la versione in cemento è disponibile in due toni, uno più chiaro e uno più scuro.

▣ **Designed by LucidiPevere in 2011, Boiaccia was created as a challenge: to make a table using a rough and imperfect material such as cement. The result, a refined and poetic table that offers special tactile and visual sensations, received an honourable mention at the Compasso d'Oro 2014. Subsequently, the Boiaccia table was given a more traditional shape, with a Pure-white laminate or Fenix-NTM® top and wood legs with a metal core - a highly technological and finely crafted product. Still very up-to-date, the cement version is available in two colours, one light and one dark.**

▣ Der im Jahr 2011 von LucidiPevere entworfene Tisch Boiaccia entstand als eine Herausforderung: einen Tisch aus einem so rohen und unvollkommenen Material wie Zement herzustellen. Das Ergebnis ist ein raffinierter und

poetischer Tisch, dem es gelingt, ganz besondere taktile und visuelle Empfindungen zu vermitteln, was zu einer ehrenvollen Erwähnung beim Compasso d'Oro 2014 führte. Der Tisch Boiaccia wurde nachfolgend in einer traditionelleren Form abgewandelt, mit einer Platte aus Laminat Pure-white oder Fenix-NTM® und Beinen aus Holz mit Metallkern - eine Realisierung von hoher technischer und handwerklicher Qualität. Die nach wie vor sehr aktuelle Version aus Zement steht in einem helleren und einem dunklerem Farbton zur Auswahl.

▣ Diseñada por LucidiPevere en el año 2011, Boiaccia nace como un desafío: crear una mesa utilizando un material bruto e imperfecto como el cemento. El resultado es una mesa refinada y poética capaz de suscitar sensaciones táctiles y visuales especiales, mención de honor en el Compás de Oro 2014. A continuación, la mesa Boiaccia ha sido declinada en una forma más tradicional, con sobre de laminado Pure-white o Fenix-NTM® y patas de madera con alma de metal: una obra de alta calidad técnica y artesanal. Actualísima todavía, la versión de cemento está disponible en dos tonos, uno más claro y otro más oscuro.

▣ Dessinée par LucidiPevere nel 2011, Boiaccia doit sa naissance à un défi : créer une table en utilisant un matériau brut et imparfait comme le ciment. Le résultat est une table raffinée et poétique, à même d'offrir des sensations tactiles

et visuelles particulières, mention d'honneur au concours « Compasso d'Oro 2014 ». Par la suite, la table Boiaccia a une forme plus traditionnelle, avec plateau en stratifié Pure-white ou Fenix-NTM® et pieds en bois avec âme en métal – une réalisation de haute qualité technique et artisanale. Encore très actuelle, la version en ciment existe en deux tonalités, une plus claire et une plus foncée.

Type

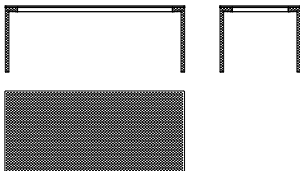

Cement version
L 200 P 90 H 74 cm
W 78^{5/8}" D 35^{1/8}" H 29^{1/8}"

L 240 P 100 H 74 cm
W 94^{4/8}" D 39^{3/8}" H 29^{1/8}"

L 140 P 140 H 74 cm
W 55^{1/8}" D 55^{1/8}" H 29^{1/8}"

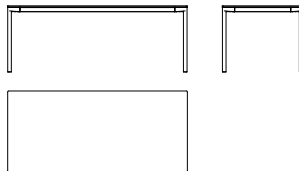

Wood version
L 200 P 90 H 73 cm
W 78^{5/8}" D 35^{1/8}" H 28^{5/8}"

L 240 P 100 H 73 cm
W 94^{4/8}" D 39^{3/8}" H 28^{5/8}"

L 280 P 110 H 73 cm
W 110^{2/8}" D 43^{2/8}" H 28^{5/8}"

L 140 P 140 H 73 cm
W 55^{1/8}" D 55^{1/8}" H 28^{5/8}"



Honourable mention ADI Compasso d'Oro 2014

Cement top/legs



Wood legs



Pure-white laminate top



Fenix-NTM® black edge top



Fenix-NTM® coloured edge top





Neat table
Fenix-NTM® top

Pulp chair
Polypropylene





1



2

Neat

DESIGN BY CHRISTOPHE PILLET, 2011

▣ Neat è ispirato ai tavoli in cui la base è costituita da una coppia di cavalletti, un classico del design contemporaneo che Christophe Pillet rilegge facendo incontrare le esigenze del mondo della casa con quelle di uno spazio di lavoro. La struttura portante è in alluminio verniciato; a seconda dello spazio disponibile le gambe possono essere montate in posizione più o meno rientrata rispetto al bordo del piano, impiallacciato in essenza o in Fenix-NTM®. Essenziale ma ricco di personalità, Neat è molto versatile e si presta a essere usato in qualsiasi ambiente, passando facilmente da tavolo da pranzo a scrivania per l'home office e viceversa.

▣ Neat is inspired by tables that have a base comprising a pair of trestles. It is a classic piece of contemporary design that Christophe Pillet reinterprets by combining the requirements of the home world with those of a workspace. It has a painted aluminium support frame. Depending on the space available, the legs can be assembled in a more or less recessed position in relation to the edge of the top. They are available in wood veneer or in Fenix-NTM®. As minimalist as it is full of personality, Neat is highly versatile and can be used in any context, easily becoming a dining table or a desk for the home office.

▣ Neat inspiriert sich an jenen Tischen, deren Grundgestell aus zwei Stützböcken besteht, ein Klassiker des zeitgenössischen Designs.

Type

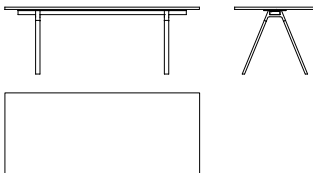

L 160 P 90 H 77 cm
W 63" D 35³/₈" H 29³/₈"

L 180 P 90 H 77 cm
W 70⁷/₈" D 35³/₈" H 29³/₈"

L 200 P 90 H 77 cm
W 78⁶/₈" D 35³/₈" H 29³/₈"

L 220 P 100 H 77 cm
W 86⁵/₈" D 39³/₈" H 29³/₈"

L 250 P 100 H 77 cm
W 98³/₈" D 39³/₈" H 29³/₈"

L 280 P 100 H 77 cm
W 110²/₈" D 39³/₈" H 29³/₈"

Christophe Pillet interpretiert den Entwurf neu und verbindet dabei die Bedürfnisse des häuslichen Umfelds mit jenen eines Arbeitsraums. Die tragende Struktur besteht aus lackiertem Aluminium und je nach vorhandenem Platzangebot können die Beine mit geringerem oder größerem Abstand zur der Kante der Tischplatte montiert werden. Letztere steht mit Holzurnier oder aus Fenix-NTM® zur Auswahl. Auf das Wesentliche beschränkt, aber von großer Persönlichkeit erweist sich Neat als sehr vielseitig und in jedem Ambiente einsetzbar und verwandelt sich vom Esstisch in einen Schreibtisch für das Home Office oder umgekehrt.

▣ Neat se inspira en las mesas que componen su base con un par de caballetes, un clásico del diseño contemporáneo que Christophe Pillet reinterpreta entrelazando las necesidades del mundo doméstico con las del espacio de trabajo. La estructura portante es de aluminio barnizado: según el espacio disponible, las patas pueden montarse en una posición más o menos entrante respecto al canto del sobre, chapado en madera o de Fenix-NTM®. Esencial pero con una fuerte personalidad, Neat es extraordinariamente versátil y se presta a ser utilizada en cualquier ambiente, pasando fácilmente de mesa de comedor a escritorio para la oficina doméstica y viceversa.

▣ Neat s'inspire des tables dont le piètement se constitue de deux tréteaux, un classique du

design contemporain que Christophe Pillet revisite en alliant les besoins du monde intérieur avec ceux d'un espace de travail. La structure portante est en aluminium laqué. Selon l'espace à disposition, les tréteaux peuvent se monter plus ou moins vers l'intérieur par rapport au bord du plateau, plaqué bois ou en Fenix-NTM®. Dotée d'une ligne épurée, mais riche de personnalité, Neat est un élément très flexible qui s'installe dans n'importe quel espace en devenant soit une table de salle à manger soit un bureau.

Aluminium legs



Fenix-NTM® top



Wood top







be—Easy table
Fenix-NTM® top

LP chair / armchair
Polypropylene w/ frontal removable upholstery Hero fabric

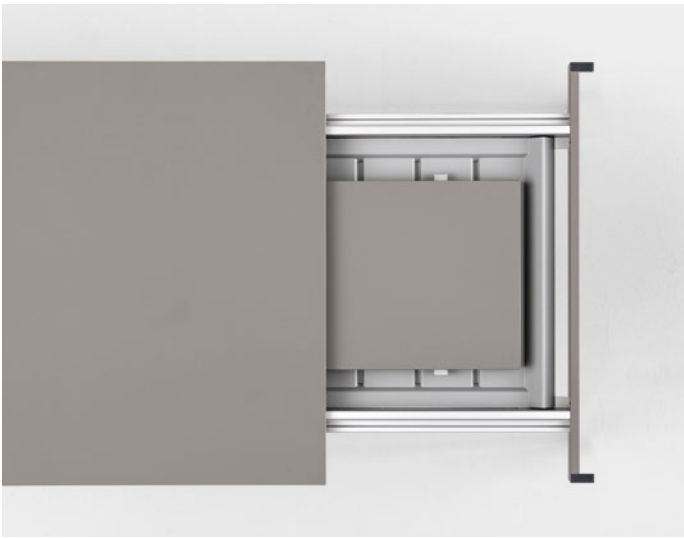

1



2

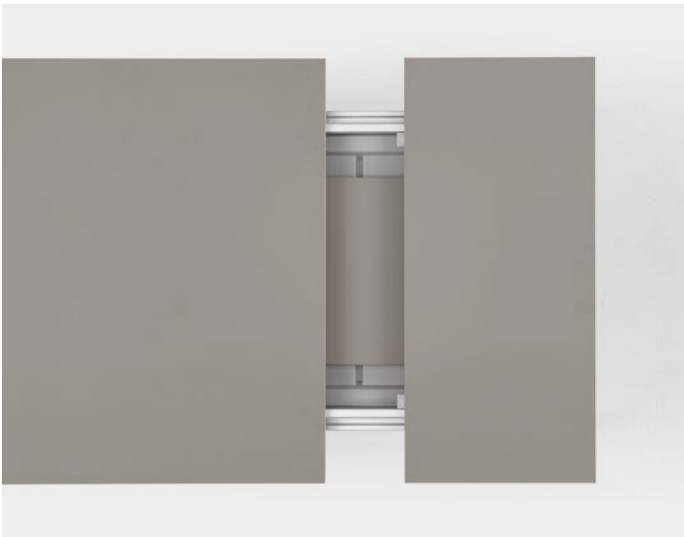

3



4

be—Easy

DESIGN BY BLUEZONE, 2015

IT be—Easy è una collezione di tavoli da interno fissi o allungabili dall'aspetto essenziale, caratterizzati da un piano in Fenix-NTM® disponibile in vari colori. NTM è infatti la sigla di NanoTech Matt, ovvero un effetto opaco antiriflettente che dona alla superficie di questo materiale un'estetica calda e morbida al tatto, oltre ad un'altissima resistenza ai graffi, alle abrasioni, al calore, alle macchie, agli urti, ai detersivi ed ai solventi. Le gambe del tavolo sono verniciate a polveri con effetto opaco morbido al tatto per creare un piacevole effetto monomaterico e monocromatico con il piano.

EN be—Easy is a collection of indoor fixed and extendable tables with minimalist appeal, featuring a Fenix-NTM® top available in various colours. NTM stands for NanoTech Matt, or the anti-reflective matt effect that gives the surface of this material its warm aesthetic and soft tactile appeal, and its high resistance to scratching, abrasion, heat, stains, impact, detergents and solvents. The table legs are powder-coated with a soft matt effect to create an attractive single-colour and single-material effect with the top.

DE be—Easy ist eine Kollektion von fixen oder verlängerbaren Tischen für den Innenbereich mit essentiellm Design, die sich durch eine in verschiedenen Farben erhältliche Platte aus Fenix-NTM® auszeichnen. NTM ist die Abkürzung für NanoTech Matt, d.h. für einen

Matteffekt mit geringster Lichtreflexion, der den Oberflächen eine warme und zum Berühren einladende Ästhetik verleiht. Weiters ist das Material kratz- und abriebfest, hitze- und fleckenresistent, stoßfest und beständig gegen herkömmliche Haushaltsreiniger und Lösungsmittel. Die Beine des Tisches weisen eine Pulverlackierung mit matter, samtiger Optik auf, um einen ansprechenden monochromatischen und einstofflichen Effekt mit der Tischplatte zu erschaffen.

ES be—Easy es una colección de mesas para interiores fijas o extensibles de aspecto esencial, caracterizadas por un sobre de Fenix-NTM® disponible en varios colores. NTM es la sigla de NanoTech Matt: un efecto mate antirreflejante que, además de aportar un aspecto estético cálido y suave al tacto en la superficie, ofrece una altísima resistencia a los arañazos, las abrasiones, el calor, las manchas, los golpes, los detergentes y los solventes. Las patas de la mesa están barnizadas con un polvo de efecto mate y suave al tacto que crea un agradable aspecto monocromático y monomaterico.

FR be—Easy est une collection de tables d'intérieur, fixes ou extensibles, aux lignes épurées, se caractérisant par leurs plateaux en Fenix-NTM® disponibles en différents coloris. NTM est en fait le sigle de NanoTech Matt, à savoir un effet mat anti-reflets en mesure de conférer, à la surface de ce matériau, à la fois une esthétique chaleureuse et douce au toucher,

ainsi qu'une très haute résistance aux rayures, aux abrasions, à la chaleur, aux taches, aux chocs, aux détergents et aux solvants. Les pieds de cette table sont en finition laqué époxy ayant un effet mat et doux au toucher de façon à créer un agréable effet monomaterique et monochromatique avec le plateau.

Sizes

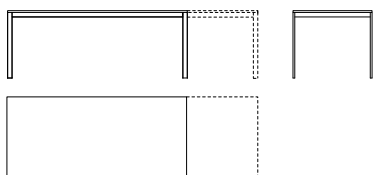

L 123/203 P 79 H 75 cm
W 48^{3/8}/79" D 31^{1/8}" H 29^{4/8}"

L 150/230 P 79 H 75 cm
W 59/90^{4/8}" D 31^{1/8}" H 29^{4/8}"

L 150/230 P 89 H 75 cm
W 59/90^{4/8}" D 35" H 29^{4/8}"

L 170/250 P 89 H 75 cm
W 66^{7/8}/98^{3/8}" D 35" H 29^{4/8}"

L 200/280 P 99 H 75 cm
W 78^{5/8}/110^{2/8}" D 39" H 29^{4/8}"

Steel legs



Fenix-NTM® top





Oops table
Lacquered top

CU occasional table
Polyurethane

Oops





Oops I Did It Again table
Wooden top

Dua wooden legs armchair
Upholstered Steelcut Trio 3 fabric

Dua on slide frame armchair
Upholstered Regal velvet fabric/Elmosoft leather

Oops I Did It Again





Oops I Did It Again table
Fenix-NTM® top



Oops I Did It Again table
Fenix-NTM® top

Compas armchair
PA6-plastic body

Lips—R removable cushion
Upholstered Field 2 fabric

Mustache—RE rug
RE-01 canvas



Oops extensible version



2



3



4



Oops I Did It Again fixed version

Oops

Oops I Did It Again

DESIGN BY MONICA GRAFFEO, 2006–2016

▣ Disegnato da Monica Graffeo nel 2006, Oops è un tavolo allungabile con base in alluminio e piano laccato spesso 50 mm che da tondo diventa ellissoidale. Un tavolo ineccepibile dal punto di vista tecnico, sia chiuso che aperto, per l'estetica e la solidità. Nel 2016 la collezione si è ampliata: la serie Oops I Did It Again include oggi due tavoli fissi con piano rotondo e un tavolo fisso con piano rettangolare, disponibili in diverse dimensioni. Le gambe sono in fusione di alluminio con spazzolatura o verniciatura e si combinano a piacere con il piano in laminato, Fenix-NTM® o impiallacciato in essenza.

EN Designed by Monica Graffeo in 2006, Oops is an extendable table with an aluminium base and a 50mm thick lacquered top that extends from a round to an ellipsoidal shape. In technical terms, this table is impeccable when closed or open due to its aesthetic appeal and sturdiness. In 2016, the collection was extended: the Oops I Did It Again range now includes two fixed tables with a round top and a fixed table with a rectangular top, available in different sizes. The legs are made of die-cast aluminium with a brushed or powder-coated lacquer finish. They can be combined as required with a top in laminate, Fenix-NTM® or wood veneer.

DE Das von Monica Graffeo im Jahr 2006 entworfene Modell Oops ist ein verlängerbarer Tisch mit Untergestell aus Aluminium und einer 50 mm starken lackierten Platte, die in der

runden Version eine Ellipsenform annimmt. Ein in Sachen Ästhetik und Stärke sowohl im geschlossenen als auch im offenen Zustand technisch einwandfreier Tisch. Im Jahr 2016 wurde die Kollektion erweitert: Die Serie Oops I Did It Again umfasst heute zwei fixe Tische mit runder Platte und einen fixen Tisch mit rechteckiger Platte, die in verschiedenen Größen erhältlich sind. Die Beine bestehen aus Pressgussaluminium in gebürsteter Ausführung oder mit Lackierung und passen perfekt zur Platte aus Laminat, Fenix-NTM® oder mit Holz furnier.

ES Diseñada por Monica Graffeo en el año 2006, Oops es una mesa extensible con base de aluminio y sobre lacado de 50 mm de espesor que pasa de ser redondo a ser elipsoidal. Una mesa impecable desde el punto de vista técnico por su estética y su solidez, tanto cerrada como abierta. La colección se ha ampliado en el año 2016: la serie Oops I Did It Again incluye ahora dos mesas fijas con sobre redondo y una mesa fija con sobre rectangular, disponibles en distintos tamaños. Las patas son de fusión de aluminio con cepillado o barnizado y pueden combinarse libremente con el sobre de laminado, Fenix-NTM® o chapado en madera.

FR Dessinée par Monica Graffeo en 2006, Oops est une table à rallonges avec piètement en aluminium et plateau rond laqué, de 50 mm d'épaisseur qui, devient ellipsoïdale quand on l'ouvre. Une table parfaite du point de vue

technique, tant ouverte que fermée, de par son esthétique et sa solidité. En 2016, la collection s'agrandit: aujourd'hui, la série Oops I Did It Again comprend deux tables fixes avec plateau rond et une table fixe avec plateau rectangulaire, déclinées en diverses dimensions. Les pieds sont en fonte d'aluminium avec une finition brossée ou laquée et s'associent à un plateau en stratifié, en Fenix-NTM® ou plaqué bois.

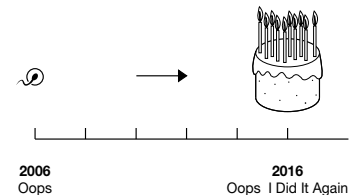

Type

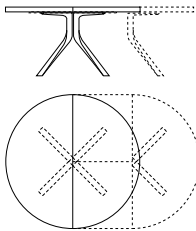

L 125/180 P 125 H 76 cm
W 49^{2/8}/70^{1/8}" D 49^{2/8}" H 29^{7/8}"

L 140/200 P 140 H 76 cm
W 55^{1/8}/78^{5/8}" D 55^{1/8}" H 29^{7/8}"

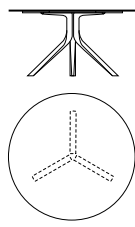

With round top - 3 legs
Ø 120 H 75 cm
W 47^{2/8}" H 29^{4/8}"

Ø 140 H 75 cm
W 55^{1/8}" H 29^{4/8}"

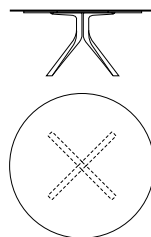

With round top - 4 legs
Ø 160 H 75 cm
W 63" H 29^{4/8}"

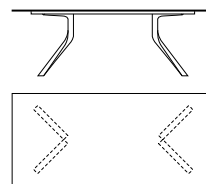

With rectangular top
L 220 P 100 H 75 cm
W 86^{5/8}" D 39^{3/8}" H 29^{4/8}"

L 250 P 100 H 75 cm
W 98^{3/8}" D 39^{3/8}" H 29^{4/8}"

L 280 P 100 H 75 cm
W 110^{2/8}" D 39^{3/8}" H 29^{4/8}"

Aluminium legs



Lacquered top for extendable version (50 mm thick)



Pure-white laminate top (10 mm thick)



Fenix-NTM® black edge top (10 mm thick)



Wood top (30 mm thick)

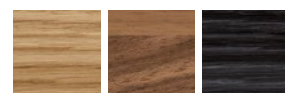

Not all finishes are available in sizes listed. Refer to current price list.



Elephant table
Bistro - double base version

Colander chair
Polypropylene body

Elephant table



Elephant table
High table

Degree occasional table
Cork



Elephant occasional table
Stone top - double base version

Elephant occasional table
Fenix-NTM® top

Brioni small lounge chair
Upholstered Elmosoft leather





Foldable version



2



3

Bistro table - Occasional table



Ø 69 H 76-50-38 cm
Ø 27 1/8" H 29 7/8-19 5/8-15"

Ø 89 H 76-50-38 cm
Ø 35" H 29 7/8-19 5/8-15"



L 69 P 69 H 76-50-38 cm
W 27 1/8" D 27 1/8" H 29 7/8-19 5/8-15"



L 89 P 89 H 76-50-38 cm
W 35" D 35" H 29 7/8-19 5/8-15"



Ø 79 H 76-50-38 cm
Ø 31 1/8" H 29 7/8-19 5/8-15"



L 79 P 79 H 76-50-38 cm
W 31 1/8" D 31 1/8" H 29 7/8-19 5/8-15"

Bistro table - Occasional table (double base)

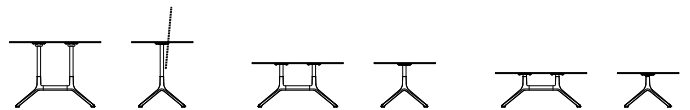

L 100 P 59 H 76-50-38 cm
W 39 3/8" D 23 2/8" H 29 7/8-19 5/8-15"

L 150 P 69 H 76-50-38 cm
W 59" D 27 1/8" H 29 7/8-19 5/8-15"

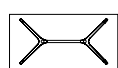

L 120 P 59 H 76-50-38 cm
W 47 2/8" D 23 2/8" H 29 7/8-19 5/8-15"

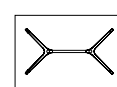

L 120 P 79 H 76-50-38 cm
W 47 2/8" D 31 1/8" H 29 7/8-19 5/8-15"



L 100 P 69 H 76-50-38 cm
W 39 3/8" D 27 1/8" H 29 7/8-19 5/8-15"

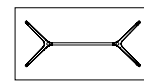

L 150 P 79 H 76-50-38 cm
W 59" D 31 1/8" H 29 7/8-19 5/8-15"

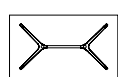

L 120 P 69 H 76-50-38 cm
W 47 2/8" D 27 1/8" H 29 7/8-19 5/8-15"



L 200 P 79 H 76-50-38 cm
W 78 5/8" D 31 1/8" H 29 7/8-19 5/8-15"

Elephant table

DESIGN BY NEULAND, 2016

▣ Richiamano l'omonima collezione di poltroncine i tavoli della serie Elephant, nati da un'evoluzione della base a trespolo della sedia girevole. Un'idea che si è via via ampliata, arrivando oggi a contare molte versioni, dal tavolino bistrot al tavolo alto, con base singola o doppia. La struttura, in alluminio pressofuso brillantato o verniciato, sostiene un piano rotondo o rettangolare, in diversi colori o in pietra (solo nella versione tavolino). Eclettici e universali, disponibili in versione fissa o pieghevole, i tavoli della serie Elephant sono adatti agli spazi più diversi, dalla cucina all'ingresso, dal salotto di casa all'ufficio.

EN **The Elephant range of tables, resulting from the evolution of the trestle base of the swivel chair, recalls the collection of chairs of the same name. The idea has gradually been extended to include many different versions, from the bistro table to the high table, with a single or a double base. The frame, in polished or painted die-cast aluminium, supports a round or rectangular top, available in various colours or in stone (only for the coffee table version). Versatile and universal, available in a fixed or a folding version, the tables in the Elephant range are ideal for the most diverse spaces, including the kitchen, entrance hall, living room and office.**

DE Die Tische der Serie Elephant erinnern an die gleichnamige Kollektion von Sesseln und sind das Ergebnis einer Weiterentwicklung des

Ständers des Drehstuhls. Eine Idee, die sich nach und nach ausgeweitet hat und heute viele Versionen umfasst, vom Bistrotisch bis zum hohen Tisch mit einzelner oder doppeltem Untergestell. Die Struktur aus glanzpoliertem oder lackiertem Aluguss trägt eine runde oder rechteckige Platte in verschiedenen Farben oder aus Stein (nur in der Version als Beistelltisch). Vielseitig und universell einsetzbar, in fixer oder klappbarer Ausführung erhältlich, eignen sich die Tische der Serie Elephant für die unterschiedlichsten Räumlichkeiten, von der Küche bis zur Diele und vom Wohnzimmer bis zum Büro.

ES Nacidas de una evolución de la base con forma de trípode de la silla giratoria, las mesas de la serie Elephant evocan la colección de butacas homónima. Una idea que ha ido ampliándose y que hoy cuenta con múltiples versiones: de la mesita bistró a la mesa alta, con base simple o doble. La estructura, de aluminio moldeado a presión abrillantado o barnizado, sostiene un sobre redondo o rectangular, en distintos colores o en piedra (solo en la versión mesita). Eclecticas y universales, disponibles en versión fija o plegable, las mesas de la serie Elephant se adaptan a los espacios más variados: de la cocina al vestíbulo, del salón de casa a la oficina.

FR Les tables de la série Elephant rappellent la collection de fauteuils du même nom. Elles sont l'évolution du piètement à branches du fauteuil

pivotant. Une idée qui s'élargit toujours plus puisqu'elle compte, aujourd'hui, de nombreuses versions : de la table bistrot à la table haute, avec pied simple ou double. La structure, en aluminium moulé sous pression brillant ou laqué, supporte un plateau rond ou rectangulaire en divers coloris ou en pierre (uniquement pour la version table basse). Eclectiques et universelles, déclinées en version fixe ou pliante, les tables de la série Elephant sont parfaites pour les espaces les plus divers, de la cuisine à l'entrée, du salon au bureau.

High table

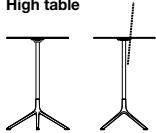

Ø 69 H 106 cm
Ø 27 1/8" H 41 6/8"



L 69 P 69 H 106 cm
W 27 1/8" D 27 1/8" H 41 6/8"



Ø 79 H 106 cm
Ø 31 1/8" H 41 6/8"



L 79 P 79 H 106 cm
W 31 1/8" D 31 1/8" H 41 6/8"

High table (double base)

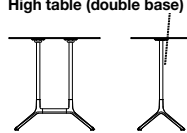

L 100 P 59 H 106 cm
W 39 3/8" D 23 3/8" H 41 6/8"

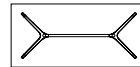

L 150 P 69 H 106 cm
W 59" D 27 1/8" H 41 6/8"

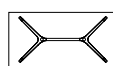

L 120 P 59 H 106 cm
W 47 2/8" D 23 3/8" H 41 6/8"



L 100 P 69 H 106 cm
W 39 3/8" D 27 1/8" H 41 6/8"

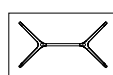

L 120 P 69 H 106 cm
W 47 2/8" D 27 1/8" H 41 6/8"

Aluminium structure



Laminate top



Fenix-NTM® black edge top



Stone top



Not all finishes are available in sizes listed. Refer to current price list.



Poule table
Bistro - double base version

Colander chair
Polypropylene body

Lips—R removable cushion
Upholstered Field 2 fabric

Poule





Poule table
Bistro - foldable version





1



2

Bistro table



Ø 59 H 75 cm
Ø 23⁵/₈" H 29⁴/₈"



L 59 P 59 H 75 cm
W 23⁵/₈" D 23⁵/₈" H 29⁴/₈"



Ø 69 H 75 cm
Ø 27¹/₈" H 29⁴/₈"



L 69 P 69 H 75 cm
W 27¹/₈" D 27¹/₈" H 29⁴/₈"

Bistro table (double base)

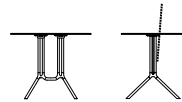

Ø 90 H 75 cm
Ø 35³/₈" H 29⁴/₈"



Ø 100 H 75 cm
Ø 39³/₈" H 29⁴/₈"



L 100 P 59 H 75 cm
W 39³/₈" D 23⁵/₈" H 29⁴/₈"



L 120 P 59 H 75 cm
W 47²/₈" D 23⁵/₈" H 29⁴/₈"



L 100 P 69 H 75 cm
W 39³/₈" D 27⁴/₈" H 29⁴/₈"



L 120 P 69 H 75 cm
W 47²/₈" D 27⁴/₈" H 29⁴/₈"



L 150 P 69 H 75 cm
W 59" D 27⁴/₈" H 29⁴/₈"



L 120 P 79 H 75 cm
W 47²/₈" D 31⁴/₈" H 29⁴/₈"



L 150 P 79 H 75 cm
W 59" D 31⁴/₈" H 29⁴/₈"

High table



Ø 59 H 110 cm
Ø 23⁵/₈" H 43²/₈"



L 59 P 59 H 110 cm
W 23⁵/₈" D 23⁵/₈" H 43²/₈"



Ø 69 H 110 cm
Ø 27¹/₈" H 43²/₈"

Poule

DESIGN BY PATRICK NORGUET, 2011

Il nome di questo tavolino dichiara senza giri di parole la sua ispirazione: la forma di una zampa di gallina, ripresa nelle linee del piedistallo e delle gambe. Un'idea spiritosa che Patrick Norguet mette in pratica seriamente, disegnando una collezione di tavoli e tavolini pratici e versatili, leggeri e resistenti, adatti all'uso nelle più diverse situazioni. Poule è realizzato in alluminio verniciato a polvere in bianco o nero e ha un piano rotondo, quadrato o rettangolare in laminato o Fenix-NTM®.

Disponibile in due altezze, Poule è anche in versione pieghevole per essere riposto quando non serve e gli spazi sono ridotti.

The name of this occasional table simply reveals its inspiration: the shape of a hen's foot, reflected in the lines of its pedestal and legs. Patrick Norguet seriously puts this clever idea into practice by designing a practical and versatile collection of tables and occasional tables. Lightweight and durable, they are ideal for use in a variety of contexts. Poule is made of black or white painted aluminium. It has a round, square or rectangular top in laminate or Fenix-NTM®. Poule is also available in a folding version so that it can be stored when not required and where space is limited.

Der Name dieses Beistelltisches verrät ohne langes Herumgerede seine Inspiration: die Form eines Hühnerfußes, der sich in den Linien des Sockels und der Beine widerspiegelt. Eine witzige Idee, die Patrick Norguet ganz ernsthaft in die

Praxis umgesetzt, indem er eine Kollektion von Tischen und Beistelltischen entwirft, die praktisch, vielseitig, leicht und langlebig sind und sich für den Einsatz in den unterschiedlichsten Situationen eignen. Poule ist aus Aluminium mit weißer oder schwarzer Pulverbeschichtung gefertigt und hat eine runde, quadratische oder rechteckige Platte aus Laminat oder Fenix-NTM®. Erhältlich in zwei Höhen, ist Poule auch in klappbaren Version erhältlich, wodurch sich der Tisch bei Nichtbenützung und wenig Platz problemlos lagern lässt.

El nombre de esta mesita declara sin medios términos su verdadera inspiración: la forma de una pata de gallina, retomada en las líneas del pedestal y de las patas. Una idea graciosa que Patrick Norguet pone en práctica seriamente diseñando una colección de mesas y mesitas prácticas y versátiles, ligeras y resistentes, adecuadas para el uso en las más variadas situaciones. Poule está realizada en aluminio barnizado con polvo en blanco o negro y tiene un sobre redondo, cuadrado o rectangular de laminado o Fenix-NTM®. Disponible en dos alturas, Poule existe también en versión plegable, para guardarla cuando no se está utilizando en ambientes reducidos.

Le nom de cette table déclare ouvertement son inspiration : la forme d'une patte de poule que l'on retrouve dans les lignes du piédestal ou des pieds. Une idée drôle que Patrick Norguet met sérieusement en pratique, en dessinant une

collection de tables et de tables basses pratiques et flexibles, légères et résistantes, convenant pour les contextes les plus divers. Poule est réalisée en aluminium laqué époxy blanc ou noir et a un plateau rond, carré ou rectangulaire en stratifié ou en Fenix-NTM®. Déclinée en deux hauteurs, Poule existe également en version pliante pour pouvoir la ranger quand elle ne sert pas ou que l'on a peu de place à disposition.

High table (double base)

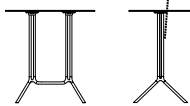

L 100 P 59 H 110 cm
W 39^{3/8}" D 23^{5/8}" H 43^{2/8}"



L 150 P 69 H 110 cm
W 59" D 27^{4/8}" H 43^{2/8}"

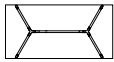

L 120 P 59 H 110 cm
W 47^{2/8}" D 23^{5/8}" H 43^{2/8}"



L 100 P 69 H 110 cm
W 39^{3/8}" D 27^{4/8}" H 43^{2/8}"

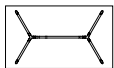

L 120 P 69 H 110 cm
W 47^{2/8}" D 27^{4/8}" H 43^{2/8}"

Aluminium structure



Laminate top



Fenix-NTM® black edge top





TNP table
Bistro

Colander chair
Upholstered Hero fabric



TNP table
Bistro

Rama chair - four legs
Wooden body

Lips - R removable cushion
Upholstered Hero fabric



1



2



TNP – Villeurbanne, France

DESIGN BY CHRISTOPHE PILLET, 2011

I Da principio, il tavolino TNP è stato creato da Christophe Pillet per il Théâtre National Populaire, un'architettura degli anni Trenta che ospita una delle più prestigiose istituzioni culturali francesi, fondata con la missione di diffondere il teatro di qualità fra il grande pubblico. L'ispirazione viene dai tavolini dei vecchi bistrot di Parigi: la base è in ghisa, un materiale tradizionale usato per un'infinità di oggetti nella metropoli francese, dai lampioni alle insegne del metrò. Personalizzata con il logo del teatro, la base sostiene un piano quadrato o rettangolare. Il tavolo, anche in versione alta, è disponibile in quattro colori: bianco, nero, verde oliva e rosso (la stessa tinta usata al Théâtre National).

EN The TNP table was first created by Christophe Pillet for the Théâtre National Populaire, a building dating back to the 1930s that houses one of France's most prestigious cultural institutions and founded to offer the general public quality theatrical performances. It was inspired by the small tables of the old bistrots in Paris: the base is made of cast iron, a traditional material used for countless objects in the French metropolis, from street lamps to metro signs. Customised with the logo of the theatre, the base supports a square or rectangular top. The table, also the high version, is available in four colours: white, black, olive green and red (the same colour used at the Théâtre National).

DE Der Tisch TNP wurde von Christophe Pillet ursprünglich für das Théâtre National Populaire entworfen, ein Gebäude aus den 30er Jahren, in dem sich eine der prestigereichsten kulturellen Institutionen Frankreichs befindet, die mit dem Ziel gegründet wurde, qualitativ hochwertiges Theater für die breite Öffentlichkeit anzubieten. Als Inspiration dienten die Stehtische der alten Pariser Bistros: Das Untergestell besteht aus Gusseisen, ein traditionelles Material, das in der französischen Hauptstadt für eine unendliche Anzahl von Objekten verwendet wird, von Straßenlaternen bis hin zu U-Bahn-Schildern. Das mit dem Logo des Theaters verzierte Untergestell aus Gusseisen trägt eine quadratische oder rechteckige Platte. Der Tisch ist auch in einer hohen Version erhältlich und wird in vier Farben angeboten: Weiß, Schwarz, Olivgrün und Rot (diese Farbe kommt auch im Théâtre National zum Einsatz).

ES Inicialmente, la mesita TNP fue creada por Christophe Pillet para el Théâtre National Populaire, una arquitectura de los años treinta que aloja una de las más prestigiosas instituciones culturales francesas, fundada con la misión de difundir el teatro de calidad entre el gran público. Se inspira en las mesitas de los viejos bistrós de París: la base es de hierro fundido, un material tradicional utilizado para una infinidad de objetos en la metrópolis francesa: de los faroles a los letreros del metro. Personalizada con el logotipo del teatro, la base sostiene un sobre cuadrado o rectangular. La mesa, también

en versión alta, está disponible en cuatro colores: blanco, negro, verde oliva y rojo (el mismo color utilizado en el Théâtre National).

FR Au départ, la table TNP fut créée par Christophe Pillet pour le Théâtre National Populaire, une architecture des années Trente qui abritait l'une des institutions culturelles françaises les plus prestigieuses, ayant pour but de faire connaître le théâtre de qualité au grand public. L'inspiration dérive des tables des vieux bistrots parisiens : le piètement en fonte, un matériau traditionnel utilisé pour une infinité d'objets dans la capitale française, des réverbères jusqu'aux enseignes du métro. Personnalisé avec le logo du théâtre, le piètement supporte un plateau carré ou rectangulaire. La table, également en version haute, est déclinée en quatre coloris : blanc, noir, vert olive et rouge (la même teinte que celle utilisée au Théâtre National).

Type

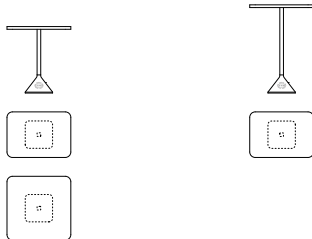

Bistro table

L 70 P 50 H 75 cm
W 27^{4/8}" D 19^{5/8}" H 29^{4/8}"

L 70 P 70 H 75 cm
W 27^{4/8}" D 27^{4/8}" H 29^{4/8}"

High table

L 70 P 50 H 100 cm
W 27^{4/8}" D 19^{5/8}" H 39^{3/8}"

Cast iron base



Steel top





BNC table
Laminate top

Pikaia chair - slide frame
Polyurethane body

Degree occasional table
Cork

BCN table





BNC high table
Laminate top



BNC occasional table
Laminate top

Degree occasional table
Polypropylene



1



2

BCN table

DESIGN BY HARRY-PAUL, 2013

IT I tavoli BCN utilizzano le gambe in faggio tornito dello sgabello BCN wood, per sostenere un piano rotondo in laminato bianco o nero. Un'idea tanto semplice quanto versatile, nata nel reparto ricerca e sviluppo di Kristalia e subito trasformata in una famiglia completa di complementi d'arredo, pronti per le più diverse situazioni d'arredo: tavolini bassi, tavoli alti e tavolini in stile "bistrot". Le gambe, dotate di funzionali piedini in gomma, possono essere in legno naturale oppure verniciato in tinta con il piano, per ottenere un effetto monocromatico.

EN BCN tables come with the same legs in lathe-turned beech as the BCN wood stool to support a round top in black or white laminate. This simple and just as versatile idea arose from the Kristalia research and development department. It was immediately transformed into a complete collection of complementary furnishing items ready for the widest range of furnishing spaces: coffee tables, high tables and bistro-style tables. The legs, with functional rubber feet, are available in natural wood or in lacquer in the same colour as the top in order to achieve a single-colour effect.

DE Die Tische BCN nutzen die Beine aus gedrehseltem Buchenholz des Hockers BCN wood, um damit eine runde Tischplatte aus weißem oder schwarzem Laminat zu stützen. Eine gleichermaßen einfache wie vielseitige Idee, die in der Forschungs- und

Entwicklungsabteilung von Kristalia erarbeitet und sofort zu einer vollständigen Kollektion von Zusatzelementen ausgeweitet wurde, die für die unterschiedlichsten Einrichtungssituationen bereit stehen: niedrige Tische, hohe Tische und Bartische im "Bistrot-Stil". Die mit funktionellen Gummifüßen ausgestatteten Beine sind in Naturholz erhältlich oder werden für einen harmonischen Einfarbeneffekt im Farbton der Tischplatte lackiert.

ES Las mesas BCN utilizan las patas de haya torneada del taburete BCN wood para sostener un sobre redondo en laminado blanco o negro. Una idea simple pero versátil, nacida del sector de investigación y desarrollo de Kristalia e inmediatamente transformada en una familia de complementos de mobiliario listos para integrarse en los más variados entornos: mesitas bajas, mesas altas y mesitas de estilo bistró. Las patas, dotadas de prácticos pies de goma, pueden ser de madera natural o barnizada a juego con el sobre para obtener un efecto monocromático.

FR Les tables BCN utilisent comme piètement les pieds en hêtre tourné du tabouret BCN wood, sur lesquels on a posé un plateau rond en stratifié blanc ou noir. C'est une idée à la fois très simple et flexible qui est née au sein du service de recherche et développement Kristalia et que l'on a rapidement transformée en une famille complète de compléments de mobilier, s'adaptant aux décorations d'intérieur les plus

variées: tables basses, tables hautes et tables style bistrot. Les pieds en bois, équipés de patins en caoutchouc, sont disponibles soit nature soit en laqué coloris assorti au plateau, pour obtenir un effet monochromatique.

Low table



Ø 55 H 33 cm
Ø 21 5/8" H 13"



Ø 65 H 45 cm
Ø 25 5/8" H 17 7/8"

Bistro table



Ø 78 H 75 cm
Ø 30 5/8" H 29 1/8"



Ø 100 H 75 cm
Ø 39 3/8" H 29 1/8"

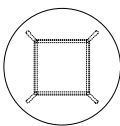

Ø 125 H 75 cm
Ø 49 1/2" H 29 1/8"

High table



Ø 78 H 100 cm
Ø 30 5/8" H 39 3/8"



Ø 100 H 100 cm
Ø 39 3/8" H 39 3/8"

Wood base



Laminate top





Constellations occasional table
H. 31-41 cm

Tenso sofa
Upholstered Curmi fabric

Mustache—GA rug
GA-03 green

Constellations

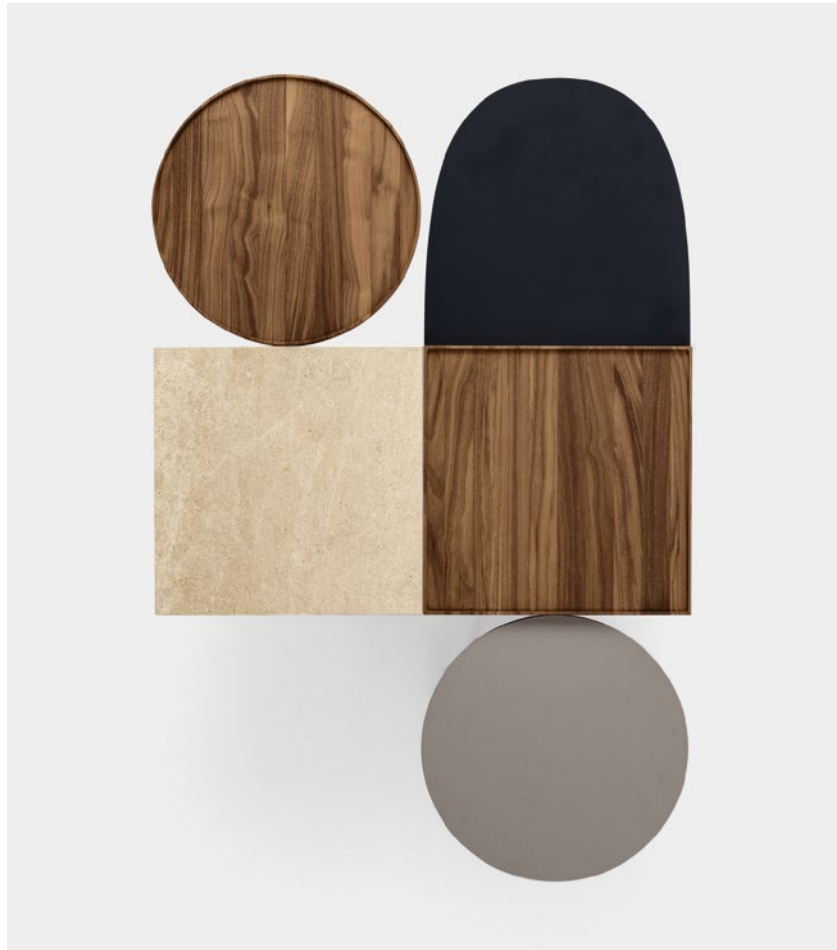



Q - walnut

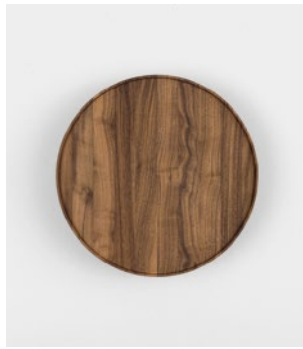

R - walnut



R - steel

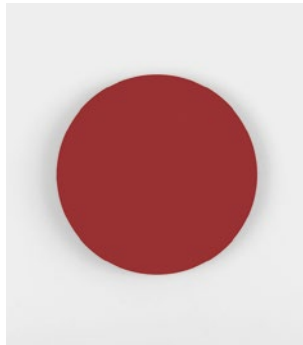

R - steel

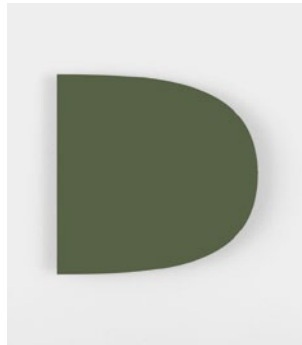

S - steel

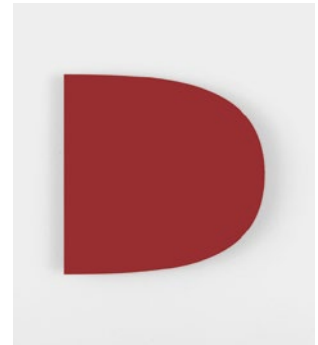

S - steel



S - steel



S - steel



S - steel



R - steel / Fenix-NTM®

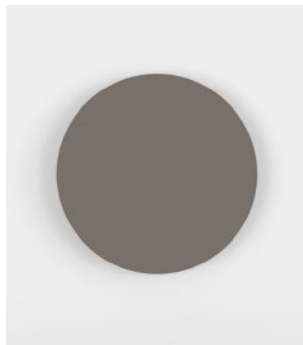

R - steel / Fenix-NTM®

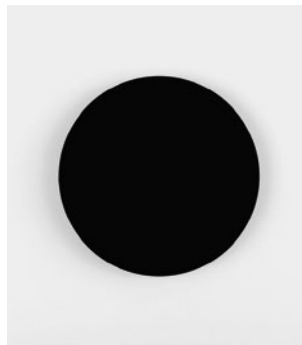

R - steel / Fenix-NTM®



Q - stone



Q - stone



S - stone



S - stone



Metal structures



Maquette

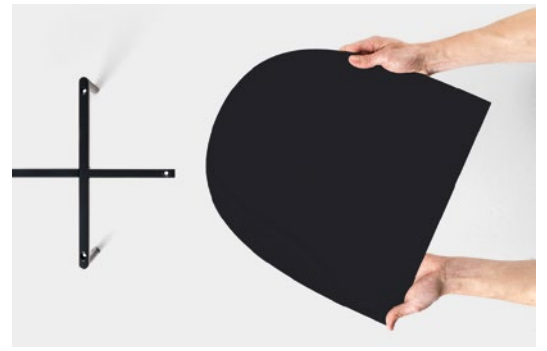

2



3



4



5

Constellations

DESIGN BY LUCA NICHETTO, 2018

I Constellations è l'omaggio di Luca Nichetto agli artisti Joan Mirò e Alexander Calder e al loro incontro, che avvenne a Parigi nel 1928. Il tavolino è costituito da una struttura in metallo, leggera e discreta, su cui è possibile combinare liberamente quadrati, cerchi e semi ellissi – ispirati alle forme concettuali di Mirò e ai *Mobiles* di Calder – per creare composizioni di superfici con vari spessori e finiture. L'effetto è un'astrazione di oggetti sospesi: una costellazione. I tavolini sono disponibili in due altezze e offrono la possibilità di combinare due, tre o quattro moduli scegliendo tra piani laccati in cinque colori oppure in legno, Fenix-NTM® o pietra.

EN Constellations is Luca Nichetto's tribute to the artists Joan Mirò and Alexander Calder and their meeting in Paris in 1928. The coffee table comprises a light and simple metal frame, on which a choice of squares, circles and semi-ellipses can be combined – inspired by Mirò's conceptual shapes and Calder's "*Mobiles*" – to create compositions of surfaces with different thicknesses and finishes. The effect is an abstraction of suspended objects: a constellation. The coffee tables are available in two heights and can combine two, three or four elements, choosing from lacquered tops in five colours or in wood, Fenix-NTM® or stone.

DE Constellations ist eine Hommage von Luca Nichetto an die Künstler Joan Mirò und

Alexander Calder und ihr Treffen im Jahr 1928 in Paris. Der Tisch besteht aus einer leichten und dezenten Metallstruktur, auf der in völliger Freiheit Quadrate, Kreise und Halbellipsen kombiniert werden können, die sich an den konzeptionellen Formen von Mirò und an den *Mobiles* von Calder inspirieren. Es entstehen so Kompositionen aus Oberflächen mit verschiedenen Stärken und in unterschiedlichen Ausführungen. Der Effekt ist eine Abstraktion von schwebenden Objekten: eine Konstellation. Die Tische sind in zwei Höhen erhältlich und bieten die Möglichkeit, zwei, drei oder vier Module zu kombinieren, wobei lackierte Platten in fünf Farben oder Platten aus Holz, Fenix-NTM® oder Stein ausgewählt werden können.

ES Constellations es el homenaje de Luca Nichetto a los artistas Joan Mirò y Alexander Calder y a su encuentro en París en el año 1928. La mesita está formada por una estructura de metal, ligera y discreta, en la que pueden combinarse libremente cuadrados, círculos y semielipses – inspirados en las formas conceptuales de Mirò y en los *Mobiles* de Calder – para crear composiciones de superficies con varios espesores y acabados. El efecto es una abstracción de objetos suspendidos: una constelación. Las mesitas están disponibles en dos alturas y ofrecen la posibilidad de combinar dos, tres o cuatro módulos eligiendo entre los sobres lacados en cinco colores o de madera, Fenix-NTM® y piedra.

FR Constellations est l'hommage de Luca Nichetto aux artistes Joan Mirò et Alexander Calder et à leur rencontre qui eut lieu à Paris en 1928. La table basse a une structure en métal, légère et discrète, sur laquelle il est possible d'allier, en toute liberté, des cercles, des carrés et des demi-ellipses – s'inspirant des formes conceptuelles de Mirò et des *Mobiles* de Calder – et de créer des compositions avec des plateaux de différentes épaisseurs et finitions. Le résultat est une abstraction d'objets suspendus: une constellation. Les tables basses ont deux hauteurs et offrent la possibilité d'unir deux, trois ou quatre modules en choisissant la finition du plateau: laqué cinq coloris, bois, Fenix-NTM® ou pierre.

Elements

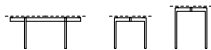

2 tops
L 80 P 40 H 31-41 cm
W 31^{1/8}" D 15^{5/8}" H 12^{2/8}-16^{1/8}"



Steel base



Wood top (20 mm thick)



Lacquered steel top (5 mm thick)

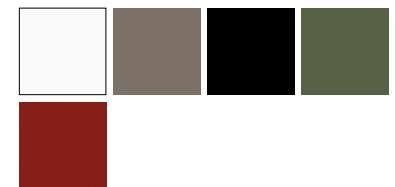

Fenix-NTM® top (10 mm thick)



Stone top (20 mm thick)

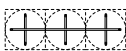
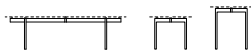

3 tops
L 120 P 40 H 31-41 cm
W 47^{7/8}" D 15^{5/8}" H 12^{2/8}-16^{1/8}"



4 tops
L 80 P 80 H 31-41 cm
W 31^{1/8}" D 31^{1/8}" H 12^{2/8}-16^{1/8}"



Degree occasional table
Polypropylene





1



2



3

Degree

DESIGN BY PATRICK NORQUET, 2011

I Tavolino, comodino, contenitore e perfino seduta: Degree è un complemento poliedrico. La sua forma strana e divertente ricorda un tocco accademico, il cappello che i laureati americani lanciano in aria durante la cerimonia che celebra la fine dell'università. Realizzato in polipropilene bianco o nero, è disponibile anche con rivestimento in sughero, un materiale dallo stile caldo e familiare che ricorda il tappo di una bottiglia. Con una piccola rotazione il piano si avvita e si svita sulla base, scoprendo un contenitore. Versatile e allegro, Degree si presta a essere usato nei contesti più diversi, dal bagno di casa alla stanza dei ragazzi.

EN A small table, a bedside table, a storage box and even a seat: Degree is a versatile furnishing accessory. Its unusual and playful shape recalls the academic world, the hat that American graduates throw into the air during the ceremony that marks the conclusion of their university degrees. Made of black or white polypropylene, it is also available with a cork coating, a material with a warm familiar style that resembles a bottle cap. With a little rotating movement, the top can be screwed on or unscrewed on the base to reveal a storage box. Versatile and fun, Degree can be used in so many different contexts, from the bathroom in the home to the children's room.

DE Beistelltisch, Nachttisch, Stauelment und sogar Sitzmöbel: Degree ist ein vielseitiges Zusatzelement. Seine seltsame und lustige Form

erinnert an jenen Doktorhut, den amerikanische Universitätsabsolventen während der feierlichen Abschlusszeremonie in die Luft werfen. Das Modell besteht aus weißem oder schwarzem Polypropylen und ist auch mit Beschichtung aus Kork erhältlich, ein Material mit warmer, familiärer Note, das an den Korken einer Flasche erinnert. Mit einer leichten Drehung lässt sich die Platte vom Grundgestell entfernen und zum Vorschein kommt ein praktischer Stauraum. Das vielseitige und heitere Modell Degree macht in den unterschiedlichsten Räumlichkeiten eine gute Figur, vom Badezimmer des Hauses bis zum Kinderzimmer.

ES Mesa, mesita de noche, contenedor e incluso asiento: Degree es un complemento poliédrico. Su forma extraña y divertida añade un toque académico, el birrete que los licenciados americanos lanzan al aire durante la ceremonia que celebra el fin de la universidad. Realizado en polipropileno blanco o negro, también está disponible con revestimiento de corcho, un material de estilo cálido y familiar que recuerda el tapón de una botella. Con una pequeña rotación, el sobre se enrosca y desenrosca en la base, descubriendo un contenedor. Versátil y alegre, Degree se presta a ser utilizado en los entornos más variados: del baño al dormitorio de los chicos.

FR Table basse, chevet, rangement ou même assise: Degree est un complément éclectique. Sa forme étrange et drôle rappelle la toque de fin

d'étude des étudiants diplômés américains qu'ils lancent en l'air lors de la cérémonie célébrant la fin de l'université. Réalisé en polypropylène blanc ou noir, il existe également revêtu en liège, un matériau au style chaud et familial qui rappelle le bouchon d'une bouteille. Une petite rotation permet de visser ou de dévisser le plateau pour laisser apparaître un rangement. Gai et multiusage, Degree peut être utilisé partout dans la maison, de la salle de bains jusqu'à la chambre des enfants.

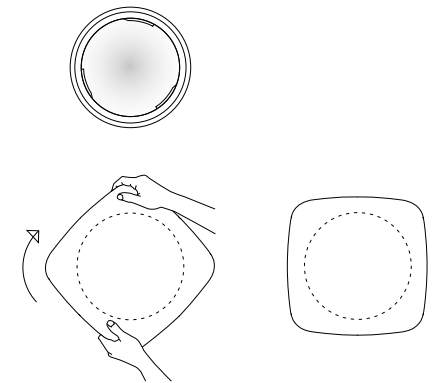

1

Elements



Base
Ø 32 H 33 cm
Ø 12 5/8" H 13"



Top hat
L 38 P 38 H 8 cm
W 15" D 15" H 3 1/8"



Cork
Ø 30 H 4 cm
Ø 11 7/8" H 1 5/8"

Polypropylene base



Polypropylene top hat



Cork



2



Font occasional table
Cristalplant®

Font





Font occasional table
Cement





1



2



3



4

Font

DESIGN BY CLAESSION KOIVISTO RUNE, 2018

I Font è una parola inglese con cui in tipografia si definisce una serie di caratteri accomunati da un determinato stile grafico. E proprio a un carattere tipografico è ispirato il nuovo tavolino disegnato dagli svedesi Claesson Koivisto Rune, servo muto accanto al divano o comodino vicino al letto. Font è disponibile in due finiture che ne definiscono lo stile: materico e scultoreo nella versione in cemento chiaro o scuro; puro e minimale in Cristalplant® bianco, un solid surface resistente, ecosostenibile e riciclabile cui può essere applicato un dispositivo con uscita USB, pratico per la ricarica dei dispositivi elettronici.

EN "Font" is an English word used in typography to define a series of characters that share a certain graphic style. The new occasional table, designed by the Swedes Claesson Koivisto Rune and inspired by a typographic character, becomes a service table when positioned next to a sofa or a bedside table when next to a bed. Font is available in two finishes that define its style: textured and sculptural in a light or dark cement version or pure and minimalist in white Cristalplant®, a resistant, eco-sustainable and recyclable solid surface, to which a device with a USB output can be applied that is handy for charging electronic devices.

DE Font ist ein englisches Wort, das in der Typografie eine Reihe von Zeichen definiert, die einen bestimmten grafischen Stil teilen. Und von einer Schriftart ließ sich auch der neue, vom

Schweden Claesson Koivisto Rune entworfene Beistelltisch inspirieren, ein stiller Diener neben dem Sofa oder ein Nachttisch neben dem Bett. Font ist in zwei Ausführungen erhältlich, die seinen Stil definieren: materisch und skulptural in der Version aus hellem oder dunklem Beton, rein und minimalistisch aus weißem Cristalplant®, eine widerstandsfähige, umweltfreundliche und recycelbare Solid Surface-Oberfläche, in die ein praktisches Gerät mit USB-Ausgang zum Laden elektronischer Geräte eingebaut werden kann.

ES En tipografía, la palabra inglesa Font designa una serie de caracteres que comparten el mismo estilo gráfico. Y la nueva mesita diseñada por los suecos Claesson Koivisto Rune se inspira precisamente en un carácter tipográfico, convirtiéndose en una mesita auxiliar junto al sofá o en una mesita de noche al lado de la cama. Font está disponible en dos acabados que definen su estilo: texturizado y escultural en la versión de cemento claro u oscuro; puro y minimalista en Cristalplant® blanco, un solid surface resistente, ecosostenible y reciclable en el que se puede aplicar un práctico elemento con salida USB para recargar los dispositivos electrónicos.

FR Font est un mot anglais avec lequel on définit, en typographie, une série de caractères d'une même famille. C'est justement un caractère typographique qui a inspiré cette nouvelle table basse dessinée par les suédois Claesson Koivisto Rune et pouvant servir de table

Sizes

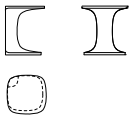

L 42 P 42 H 52 cm
W 16^{1/8}" D 16^{1/8}" H 20^{1/8}"

d'appoint dans un salon ou de chevet dans une chambre. Font est déclinée dans deux finitions qui en définissent le style : matière et sculpturale en ciment clair ou foncé, pure et minimaliste en Cristalplant® blanc, un solid surface résistant, durable et recyclable sur lequel on pourra installer un port USB pour charger les divers dispositifs électroniques.

Cristalplant®



Cement

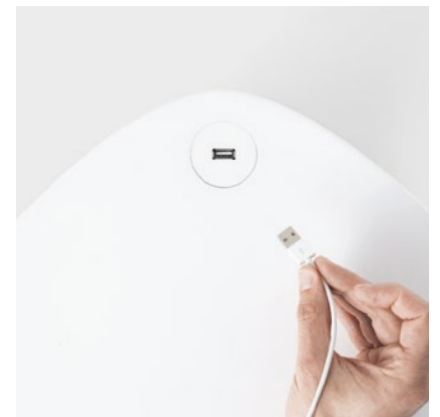



CU occasional table
L. 65 cm



CU occasional table
L. 45 cm

Mustache—SA rug
SA-03 terracotta brown



1



2



3

CU

DESIGN BY MONICA GRAFFEO, 2005

I Progettato da Monica Graffeo, CU è un elemento a forma di C in poliuretano stampato, pensato per soddisfare una gamma sorprendente di esigenze quotidiane. A seconda di come viene posizionato può essere usato come tavolino, servo muto, vassoio, comodo, piccola libreria o seduta: un universo di possibilità per una struttura creativa, pratica e resistente, da usare sola o in coppia. CU è disponibile in due misure e sei colori.

EN Designed by Monica Graffeo, CU is a C-shaped element in moulded polyurethane, designed to meet a surprising range of everyday requirements. Depending on where it is positioned, it can become a coffee table, service table, tray, bedside table, small bookcase or seat: a host of options for a creative, practical and resistant structure, which can be used alone or in pairs. CU is available in two sizes and six colours.

DE Das von Monica Graffeo entworfene C-förmige Element CU aus formgepresstem Polyurethan erfüllt eine überraschende Anzahl alltäglicher Bedürfnisse. Je nach Positionierung kann es als Beistelltisch, stiller Diener, Tablett, Nachttisch, kleines Bücherregal oder Sitzmöbel verwendet werden: ein Universum von Möglichkeiten für eine kreative, praktische und widerstandsfähige Struktur, die allein oder zu zweit einsetzbar ist. CU wird in zwei Größen und sechs Farben angeboten.

ES Diseñado por Monica Graffeo, CU es un elemento en forma de C de poliuretano moldeado, pensado para satisfacer una sorprendente gama de necesidades cotidianas. Dependiendo de cómo se coloca, puede usarse como mesa, mesita auxiliar, bandeja, mesita de noche, pequeña librería o asiento: un universo de posibilidades en una estructura creativa, práctica y resistente que puede utilizarse sola o en pareja. CU está disponible en dos medidas y seis colores.

FR Conçu par Monica Graffeo, CU est un élément en forme de C en polyuréthane moulé, créé pour répondre à une surprenante gamme de besoins quotidiens. Selon l'endroit et la pièce où il est installé, il pourra faire office de petite table, de table d'appoint, de plateau, de chevet, de rangement pour livres ou de siège : un univers de possibilités pour un élément créatif, pratique et résistant, utilisable individuellement ou par deux. CU existe en deux dimensions et six coloris.

Sizes



L 45 P 40 H 40 cm
W 17^{5/8}" D 15^{5/8}" H 15^{5/8}"



L 65 P 40 H 40 cm
W 25^{5/8}" D 15^{5/8}" H 15^{5/8}"

Polyurethane body

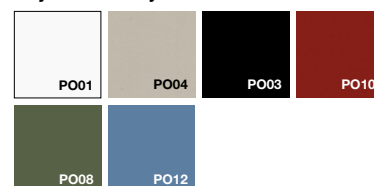



Open book on the floor

Yellow figurine

Colorful striped vase

Glasses on the coffee table

Book on the coffee table

Think Dutch

relaxed home

10X10 / 3

Books on the coffee table

Grey sofa with pillows

Person sitting on the sofa

Desk lamp on a white side table

Grey curtains on the window

Large window overlooking a green landscape



Rotor occasional table
Fenix-NTM® top

Degree occasional table
Polypropylene



1

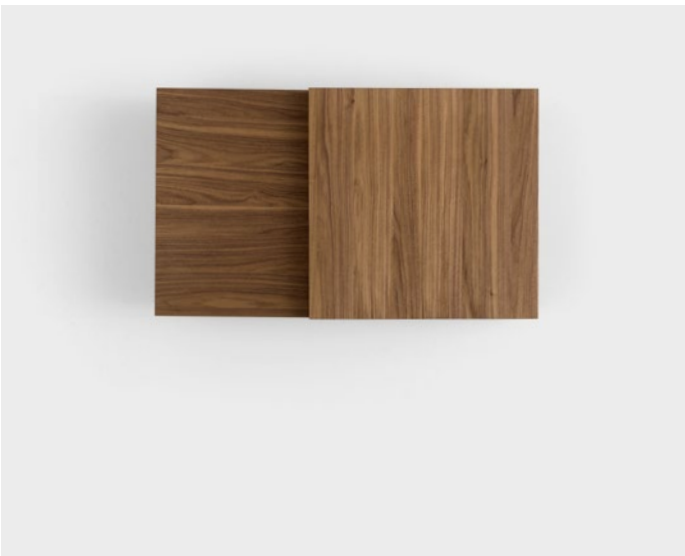

2

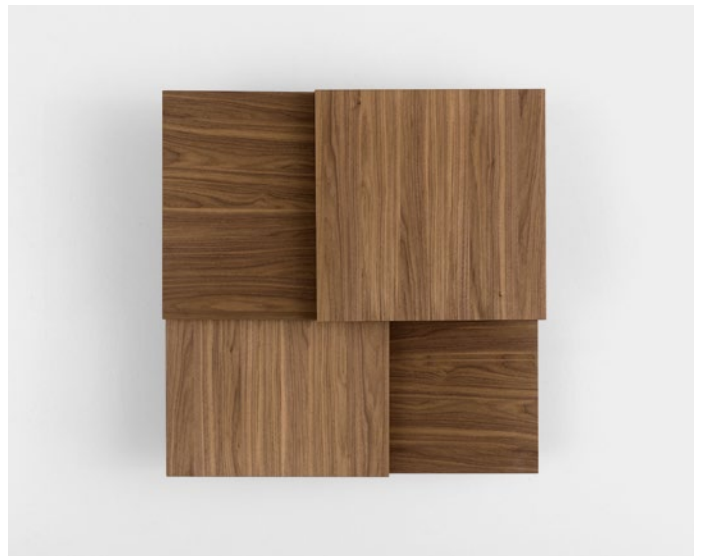

3



4

Rotor

DESIGN BY LUCIANO BERTONCINI, 2002/2009

I Rotor è un tavolino da salotto costituito da cinque superfici sovrapposte. Il piano superiore e quello inferiore sono fissi, mentre i tre piani centrali possono ruotare a 360° creando infinite geometrie – regolari o irregolari – che moltiplicano la superficie d'appoggio fino a quattro volte. Quando è completamente chiuso, invece, Rotor è un elemento discreto ed essenziale, compatto nell'ingombro. I piani sono disponibili in diverse finiture: in essenza, nei colori laccati lucidi e in Fenix-NTM® dal particolare effetto opaco.

EN Rotor is a coffee table for the living room comprising five overlapping surfaces. The upper and lower tops are fixed, whereas the three middle tops can rotate 360°, providing various regular or irregular shapes that increase the surface area even four-fold. When completely closed, Rotor becomes a simple minimalist element, compact in size. The tops are available in different finishes: in wood, gloss lacquered colours and Fenix-NTM® with a special matt effect.

DE Rotor ist ein Beistelltisch für das Wohnzimmer, der aus fünf übereinanderliegenden Flächen besteht. Die obere und die untere Platte sind fix, die drei mittleren Platte können hingegen um 360° gedreht werden, wodurch unzählige regelmäßige oder unregelmäßige Geometrien entstehen, die die Ablagefläche bis um das Vierfache vergrößern. Vollständig geschlossen präsentiert

sich Rotor als ein dezentes und essentielles Element, das wenig Platz benötigt. Die Platten sind in verschiedenen Ausführungen erhältlich: aus Holz, in glänzender Farblackierung und aus Fenix-NTM® mit besonderem Matteffekt.

ES Rotor es una mesita de salón formada por cinco superficies superpuestas. El tablero superior y el inferior son fijos, mientras que los tres tableros centrales pueden girar a 360° creando infinitas geometrías —regulares o irregulares— que llegan a multiplicar hasta cuatro veces la superficie de apoyo. Cuando está completamente cerrado Rotor es un elemento discreto y esencial, de volumen compacto. Sus tableros están disponibles en varios acabados: en madera, en los colores lacados brillantes y en Fenix-NTM® con un particular efecto mate.

FR Rotor est une table basse de salon formée de 5 plateaux superposés. Les plateaux supérieur et inférieur sont fixes alors que les trois plateaux centraux peuvent tourner à 360° en créant une infinité de formes – régulières ou irrégulières – et en multipliant par quatre les plans de dépose. Quand elle est totalement fermée, Rotor devient un élément épuré, discret et compact. Les plateaux existent en différentes finitions: en bois, en laqué brillant et en Fenix-NTM® avec un aspect mat particulier.

Sizes

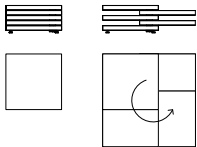

L 63/105 P 63/105 H 31 cm
W 24^{6/8}/41^{3/8}" D 24^{6/8}/41^{3/8}" H 12^{2/8}"

Wood tops

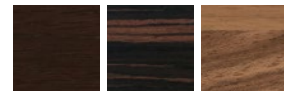

Fenix-NTM® tops



Gloss lacquered tops





Blio storage units
Lacquered

Blio	242
Box / BoxOne	260
Bureau	272
Dot Shelving System	250
Extra Large	266
Hang – Up	268
Lips	274
Mustache – GA	284
Mustache – RE	288
Mustache – SA	290
Sofa cushions	278



Blio storage units
Lacquered

Blio





Blio storage units
Lacquered





Blio storage units
Lacquered





1



2



3



4



5

Blio

DESIGN BY NEULAND, 2012

▣ Disegnato dallo studio Neuland, che si è ispirato alle biblioteche (anche per il nome), Blio reinterpreta il concetto di libreria con l'idea di organizzare qualsiasi spazio con semplicità e personalità. È costituito da una serie di elementi modulari laccati bianchi, che si offrono alla vista frontale come una successione di superfici di altezze e profondità diverse, disegnate da luci e ombre. Un progetto dalle grandi potenzialità, perché variando la destinazione d'uso dei vari moduli è possibile organizzare non solo i libri, ma tutto ciò che si trova in un ambiente domestico. A questo scopo i contenitori sono dotati sia di ripiani a vista sia di ante con apertura push-pull, ma anche di accessori porta scope e porta scarpe.

EN **Designed by the Neuland studio, which found inspiration in libraries (hence its name), Blio reinterprets the concept of a bookcase based on the idea of organising any space with simplicity and character. It comprises a series of white lacquered modular components, which from a front view appear to be a succession of surfaces in different heights and depths, created by lights and shadows. This design project has great potential because by varying the intended use of the various elements, you can organise not only books but also everything that can be found in a home setting. The storage units are therefore equipped with visible shelves and doors with a push-pull opening, as well as a broom holder and a shoe rack.**

DE Das Studio Neuland ließ sich beim Entwurf von Blio von alten Bibliotheken inspirieren (daher auch der Name) und folgte der Idee, das Konzept der Bücherregale neu zu interpretieren, um jeden Raum auf einfache und sehr persönliche Weise zu organisieren. Das System besteht aus einer Reihe von modularen, weiß lackierten Elementen, die sich von vorne wie eine Abfolge von Oberflächen in unterschiedlicher Höhe und Tiefe präsentieren, die von Licht und Schatten gezeichnet werden. Ein Projekt mit großem Potenzial, denn durch die Änderung des Verwendungszwecks der verschiedenen Module lassen sich nicht nur Bücher, sondern alles, was sich im häuslichen Umfeld befindet, perfekt organisieren. Für diesen Zweck sind die Möbelemente sowohl mit offenen Fachböden als auch mit Türen mit Push-Pull-Öffnung sowie mit Zubehör wie Besenhalter und Schuhfächern ausgestattet.

ES Diseñado por el estudio Neuland, que se ha inspirado en las bibliotecas (incluso para elegir su nombre), Blio reinterpreta el concepto de librería con la idea de organizar cualquier espacio con simplicidad y personalidad. Está formado por una serie de elementos modulares lacados en blanco que se ofrecen a la vista frontal como una secuencia de superficies de alturas y profundidades distintas, delineadas por luces y sombras. Un proyecto con un gran potencial, dado que es suficiente cambiar la función de sus módulos para organizar no solo los libros, sino todos los objetos que se

encuentran en el ambiente doméstico. Con este fin, los contenedores están dotados de estantes a la vista y de puertas con apertura push-pull, así como de accesorios para las escobas o los zapatos.

FR Dessiné par l'agence Neuland, qui s'est inspirée des bibliothèques (même pour le nom), Blio en réinterprète le concept avec l'idée d'organiser l'espace avec simplicité et personnalité à travers des éléments modulaires laqués blancs qui, vus de face, forment une succession de façades avec des hauteurs et des profondeurs différentes créant un jeu de lumières. Un projet aux nombreuses possibilités puisque, selon l'emplacement des modules, il permet de ranger non seulement des livres, mais toute une série d'objets domestiques. Voilà pourquoi les modules sont dotés de tablettes apparentes, de portes avec ouverture push-pull ou d'accessoires comme le range-balais ou le range-chaussures.

Elements

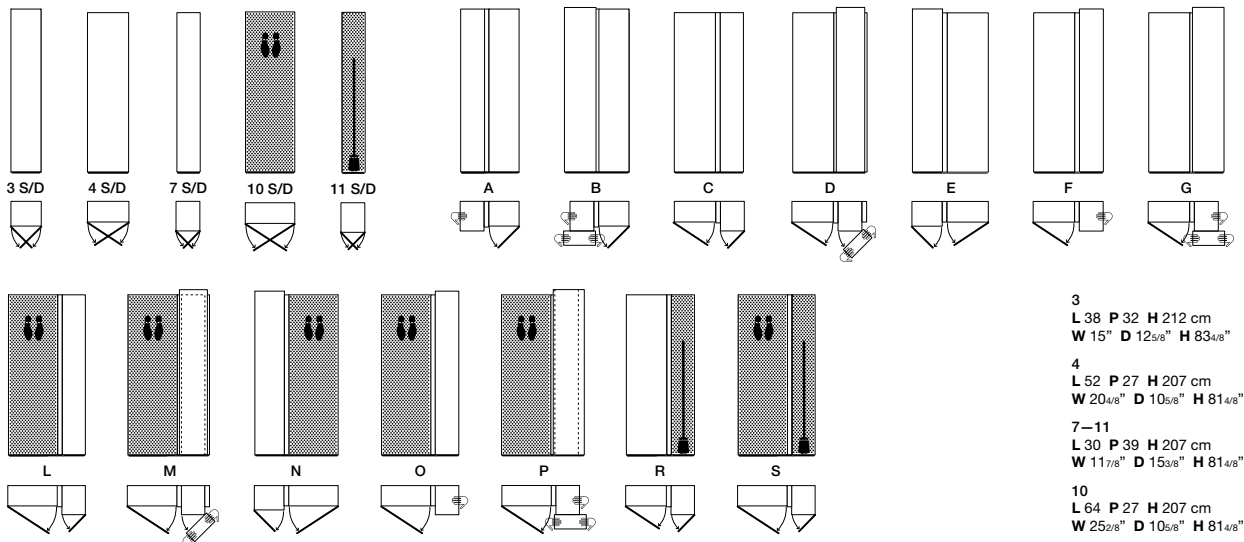

A
L 73,5 P 37 H 212 cm
W 28¹/₈" D 14⁵/₈" H 83⁴/₈"

C-R
L 87,5 P 39 H 207 cm
W 34⁴/₈" D 15³/₈" H 81⁴/₈"

E
L 95,5 P 33 H 212 cm
W 37⁵/₈" D 13" H 83⁴/₈"

G
L 95,5 P 55 H 214 cm
W 37⁵/₈" D 21⁵/₈" H 84²/₈"

M
L 105 P 52 H 214 cm
W 41³/₈" D 20⁴/₈" H 84²/₈"

O
L 99,5 P 37 H 212 cm
W 39¹/₈" D 14⁵/₈" H 83⁴/₈"

B
L 81,5 P 55 H 214 cm
W 32" D 21⁵/₈" H 84²/₈"

D
L 93 P 52 H 214 cm
W 36⁵/₈" D 20⁴/₈" H 84²/₈"

F
L 87,5 P 37 H 212 cm
W 34⁴/₈" D 14⁵/₈" H 83⁴/₈"

L-S
L 99,5 P 39 H 207 cm
W 39¹/₈" D 15³/₈" H 81⁴/₈"

N
L 107,5 P 33 H 212 cm
W 42³/₈" D 13" H 83⁴/₈"

P
L 107,5 P 55 H 214 cm
W 42³/₈" D 21⁵/₈" H 84²/₈"

3
L 38 P 32 H 212 cm
W 15" D 12⁵/₈" H 83⁴/₈"

4
L 52 P 27 H 207 cm
W 20⁴/₈" D 10³/₈" H 81⁴/₈"

7-11
L 30 P 39 H 207 cm
W 11⁷/₈" D 15³/₈" H 81⁴/₈"

10
L 64 P 27 H 207 cm
W 25²/₈" D 10³/₈" H 81⁴/₈"



Dot Shelving System
Metal lacquered

Tenso sofa
Upholstered Steelcut Trio 3 fabric

Degree occasional table
Polypropylene

Mustache—SA rug
SA-01 green

Dot Shelving System





Dot Shelving System
Metal lacquered



Dot Shelving System
Metal lacquered

Elephant 5—spoke with castors armchair
Upholstered Divina MD fabric



Dot Shelving System
Metal lacquered







Dot Shelving System
Metal lacquered



1



2



3



4



5



6



7

Dot Shelving System

DESIGN BY BLUEZONE — M. GRAFFEO, 2004

IT Dot è un sistema versatile pensato per arredare qualsiasi spazio della casa, un'architettura leggera composta di pochi, semplici elementi che danno vita a infinite soluzioni. Si compone di sottili mensole in lamiera verniciata e leggeri montanti in estruso di alluminio anodizzato, disponibili in sei dimensioni o fatti su misura. Gli accessori come fianchetti, reggilibri, tubi illuminanti, porta abiti e contenitori pensili ne moltiplicano le possibilità d'uso: dal salotto – dove Dot è una libreria essenziale che quasi scompare – alla cucina, dall'angolo dedicato all'home office al guardaroba, dal ripostiglio all'ingresso. Un progetto trasversale per organizzare in totale libertà ogni stanza della casa.

EN Dot is a versatile system designed to furnish any space in the home, a light design element consisting of a few simple components that can lead to a multitude of solutions. It comprises narrow painted sheet metal shelves and light extruded anodized aluminium uprights, available in six different sizes or custom-made. Accessories such as side panels, bookends, lighting tubes, clothes hooks and wall storage units provide many other options for use: from the living room, where Dot is a minimalist bookcase that almost disappears, to the kitchen, the home office corner, the wardrobe and the closet at the entrance. This versatile design project helps you organise every room in the home, as you desire.

Elements

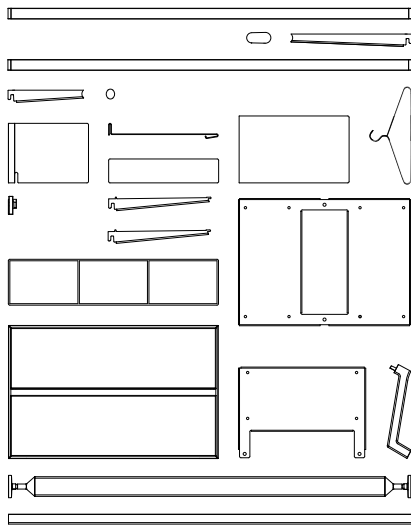

DE Dot ist ein vielseitiges System, das jeden Raum des Heims einrichtet. Es besitzt eine leichte, aus einigen wenigen, einfachen Elementen bestehende Architektur, die unzählige Lösungen hervorbringt. Es besteht aus dünnen Regalen aus lackiertem Blech und leichten Pfosten aus stranggepresstem, eloxiertem Pressgussaluminium, die in sechs Größen oder nach Maß gefertigt erhältlich sind. Die Zubehörteile wie Seitenblenden, Buchstützen, Leuchtröhren, Kleiderhalter und Hängeelemente vervielfältigen die Einsatzmöglichkeiten: vom Wohnzimmer, wo Dot ein essentielles, beinahe unsichtbares Bücherregal bildet, bis zur Küche, von der Ecke für das Home Office bis zum Kleiderschrank, vom Abstellraum bis zur Diele. Ein raumübergreifendes Projekt, um in völliger Freiheit jeden Raum des Heims zu organisieren.

ES Dot es un sistema versátil pensado para amueblar cualquier espacio de la casa, una arquitectura ligera compuesta por pocos, simples elementos que dan vida a infinitas soluciones. Está compuesto por finos estantes de chapa barnizada y ligeros montantes de aluminio anodizado extruido, disponibles en seis tamaños o realizados a medida. Los accesorios, como los costados, sujeta-libros, barras luminosas, colgadores y contenedores colgantes, multiplican sus posibilidades de uso: del salón —donde Dot es una librería esencial que casi desaparece— a la cocina, el rincón dedicado a la oficina doméstica, el guardarropa, la despensa o el vestíbulo. Un proyecto

transversal para organizar con plena libertad cualquier habitación de la casa.

FR Dot est un système multifonctionnel créé pour meubler n'importe quel espace intérieur, avec une structure légère se composant de quelques simples éléments donnant vie à une infinité de solutions: des étagères fines en tôle laquée et des montants légers en aluminium extrudé anodisé déclinés en six dimensions ou réalisés sur mesure. Les accessoires comme les côtés, les serre-livres, les éclairages, les tringles de penderie et les rangements en multiplient les possibilités d'utilisation: dans le salon où Dot est une bibliothèque aux lignes épurées presque invisibles, la cuisine, le bureau, le dressing, le débarras ou l'entrée. Un projet transversal pour organiser, en toute liberté, chaque pièce intérieure.

Aluminium upright



Steel shelf





Box wall cabinet
Mirror door

Box





BoxOne wall cabinet
Mirror door

BoxOne



BoxOne handles
Natural or black Presot® hide and soft opaline silicone



Box handle



2



3



Foot

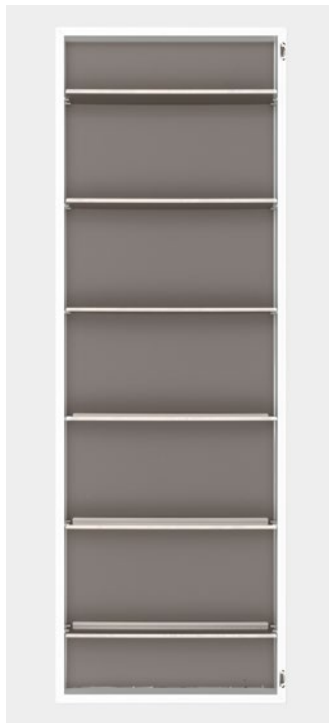

Duty



Coat

Box

BoxOne

DESIGN BY LUCIANO BERTONCINI, 2004/2009—2018

I Box è un contenitore da parete semplice e multifunzionale. Nato dalla creatività di Luciano Bertoncini, è caratterizzato da un'estetica minimale e da una grande versatilità d'utilizzo. La struttura, in alluminio leggero e resistente, incornicia un'anta a specchio che nasconde ripiani multiuso, appendiabiti e porta scarpe. Nella variante BoxOne, l'anta è interamente a specchio e si apre con una maniglia esterna, da scegliere in cuoio Presot® nero o naturale oppure in silicone opalino morbido. Come nella versione precedente, l'anta si apre a 180° con cerniere a scomparsa. Compatti ed essenziali, Box e BoxOne sono pensati per completare qualsiasi ambiente della casa, dal bagno all'ingresso, alla camera da letto.

EN Box is a simple multifunctional wall cabinet. The result of the creative talent of Luciano Bertoncini, it features minimalist aesthetic appeal and great versatility for use. The frame, in light hardwearing aluminium, frames a mirror door that conceals multipurpose shelves, clothes hooks and shoe racks. In the BoxOne version, the door has a full-length mirror and opens with an external handle, in a choice of black or natural Presot® hide or soft opaline silicone. Like the previous version, the door opens to 180° and has concealed hinges. Compact and minimalist, Box and BoxOne are designed to complement any room in the home, from the bathroom to the entrance hall and the bedroom.

DE Box ist ein einfaches und multifunktionelles Hängeelement. Es entspringt der Kreativität von Luciano Bertoncini und zeichnet sich durch eine minimale Ästhetik und eine große Vielseitigkeit bei der Verwendung aus. Die Struktur aus leichtem und widerstandsfähigem Aluminium umrahmt eine Tür aus Spiegelglas, hinter der sich Mehrzweckböden, Kleiderhaken oder Schuhablagen verbergen. In der Variante BoxOne besteht die Tür ganz aus Glas und lässt sich mit einem außenliegenden Griff öffnen, der aus schwarzem oder naturfarbigem Leder von Presot® oder aus weichem mattem Silikon erhältlich ist. Wie bereits bei der bisherigen Version besitzt die Tür ein verdeckt montiertes Scharnier mit 180°-Öffnungswinkel. Die kompakten und essenziellen Hängeelemente Box und BoxOne sind die perfekte Vervollständigung für jeden Raum des Hauses, vom Bad über die Diele bis hin zum Schlafzimmer.

ES Box es un contenedor de pared simple y multifuncional. Nacido de la creatividad de Luciano Bertoncini, se caracteriza por su estética minimalista y por su gran versatilidad de uso. La estructura, de aluminio ligero y resistente, enmarca una puerta con espejo que oculta estantes multiuso, colgadores y zapateros. En la variante BoxOne, el espejo cubre toda la puerta, que se abre con un tirador externo de cuero Presot® negro o natural o de silicona opalina suave. Como en la versión anterior, la puerta se abre a 180° con bisagra oculta. Compactos y esenciales, Box y BoxOne están pensados para

completar cualquier ambiente de la casa: del baño al vestíbulo o el dormitorio.

FR Box est un meuble de rangement simple et multifonctionnel. Issu de la créativité de Luciano Bertoncini, il a une esthétique minimaliste et permet de multiples usages. La structure en aluminium léger et résistant encadre une porte miroir qui cache des tablettes, des patères ou un range-chaussures. Le modèle BoxOne a, en revanche, une porte miroir sans cadre et s'ouvre avec une poignée extérieure soit en cuir Presot® noir ou naturel soit en silicone souple opalin. Comme dans la version précédente, la porte montée sur charnières invisibles s'ouvre à 180°. Compacts et épurés, Box et BoxOne ont été pensés pour toutes les pièces intérieures: de la salle de bains à l'entrée jusqu'à la chambre.

Type

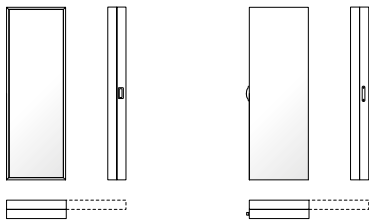

Box
L 65 P 20 H 190 cm
W 25^{5/8}" D 7^{7/8}" H 74^{6/8}"

BoxOne
L 65 P 20 H 190 cm
W 25^{5/8}" D 7^{7/8}" H 74^{6/8}"

Interior fittings

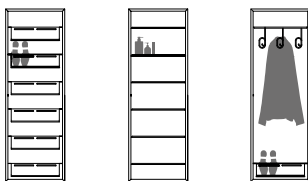

Foot

Duty

Coat

Aluminium frame



Internal shelf finishes





1



2

Extra Large

DESIGN BY LUCIANO BERTONCINI, 2000/2009

▣ Luciano Bertoncini disegna una collezione di specchi rettangolari di grandi dimensioni, da appendere o appoggiare alla parete per rendere più ampi e luminosi gli spazi domestici o collettivi. Disponibili in due altezze e quattro larghezze, gli specchi Extra Large sono caratterizzati da una profonda cornice in trafilato di alluminio anodizzato o verniciato bianco, essenziale e geometrica. La superficie a specchio è quindi leggermente rientrante, così da creare un interessante gioco prospettico. Complementi funzionali capaci di dare un tocco particolare a qualsiasi ambiente, gli specchi possono essere appesi sia in verticale sia in orizzontale.

EN Luciano Bertoncini has designed a collection of large rectangular mirrors to hang on or lean against a wall, thus extending home or community spaces and making them brighter. Available in two heights and four widths, Extra Large mirrors feature a simple geometric thick frame in drawn anodized aluminium or white painted frame. The mirror surface is therefore slightly recessed so as to create an interesting perspective effect. These functional accessories that add a special touch to any context, can be hung vertically or horizontally.

▣ Luciano Bertoncini entwirft eine Kollektion von rechteckigen großflächigen Spiegeln, die aufgehängt oder einfach an die Wand gelehnt werden können, um Wohn- oder Gemeinschaftsräumen mehr Tiefe und Helle zu

schenken. Die Spiegel Extra Large sind in zwei Höhen und vier Breiten erhältlich und zeichnen sich durch einen essenziellen und geometrischen Rahmen aus stranggepresstem Aluminium in eloxierter oder weiß lackierter Ausführung aus. Die Spiegeloberfläche ist etwas tiefer in den Rahmen eingesetzt und erzeugt so ein interessantes Spiel der Perspektiven. Funktionelle Einrichtungselemente, die jedem Raum ein ganz besonderes Flair verleihen und sowohl senkrecht als auch waagrecht aufgehängt werden können.

▣ Luciano Bertoncini diseña una colección de espejos rectangulares de grandes dimensiones, para colgar o apoyar en la pared, que hacen más amplios y luminosos los espacios domésticos o colectivos. Disponibles en dos alturas y cuatro anchuras, los espejos Extra Large se caracterizan por su profundo marco de aluminio trefilado anodizado o barnizado blanco, esencial y geométrico. La superficie del espejo forma así un ligero entrante que crea un interesante juego de perspectiva. Complementos funcionales capaces de aportar un toque especial en cualquier ambiente, los espejos pueden colgarse en posición vertical u horizontal.

▣ Luciano Bertoncini a dessiné une collection de miroirs rectangulaires de grandes dimensions, à suspendre ou à poser contre le mur, pour agrandir les espaces domestiques ou collectifs et les rendre plus lumineux. Déclinés en deux hauteurs et quatre largeurs, les miroirs Extra

Large se distinguent par un cadre en saillie, épuré et géométrique, en aluminium tréfilé anodisé ou laqué blanc. La glace est donc légèrement rentrante afin de créer un séduisant jeu de perspective. Compléments fonctionnels à même de donner une touche particulière à n'importe quel espace intérieur, les miroirs se suspendent en pose verticale ou horizontale.

Type

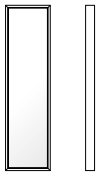

L 50 P 10 H 185 cm
W 19^{5/8}" D 3^{7/8}" H 72^{7/8}"



L 90 P 10 H 210 cm
W 35^{3/8}" D 3^{7/8}" H 82^{5/8}"

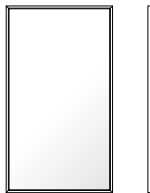

L 120 P 10 H 210 cm
W 47^{2/8}" D 3^{7/8}" H 82^{5/8}"

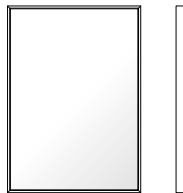

L 150 P 10 H 210 cm
W 59" D 3^{7/8}" H 82^{5/8}"

Aluminium frame



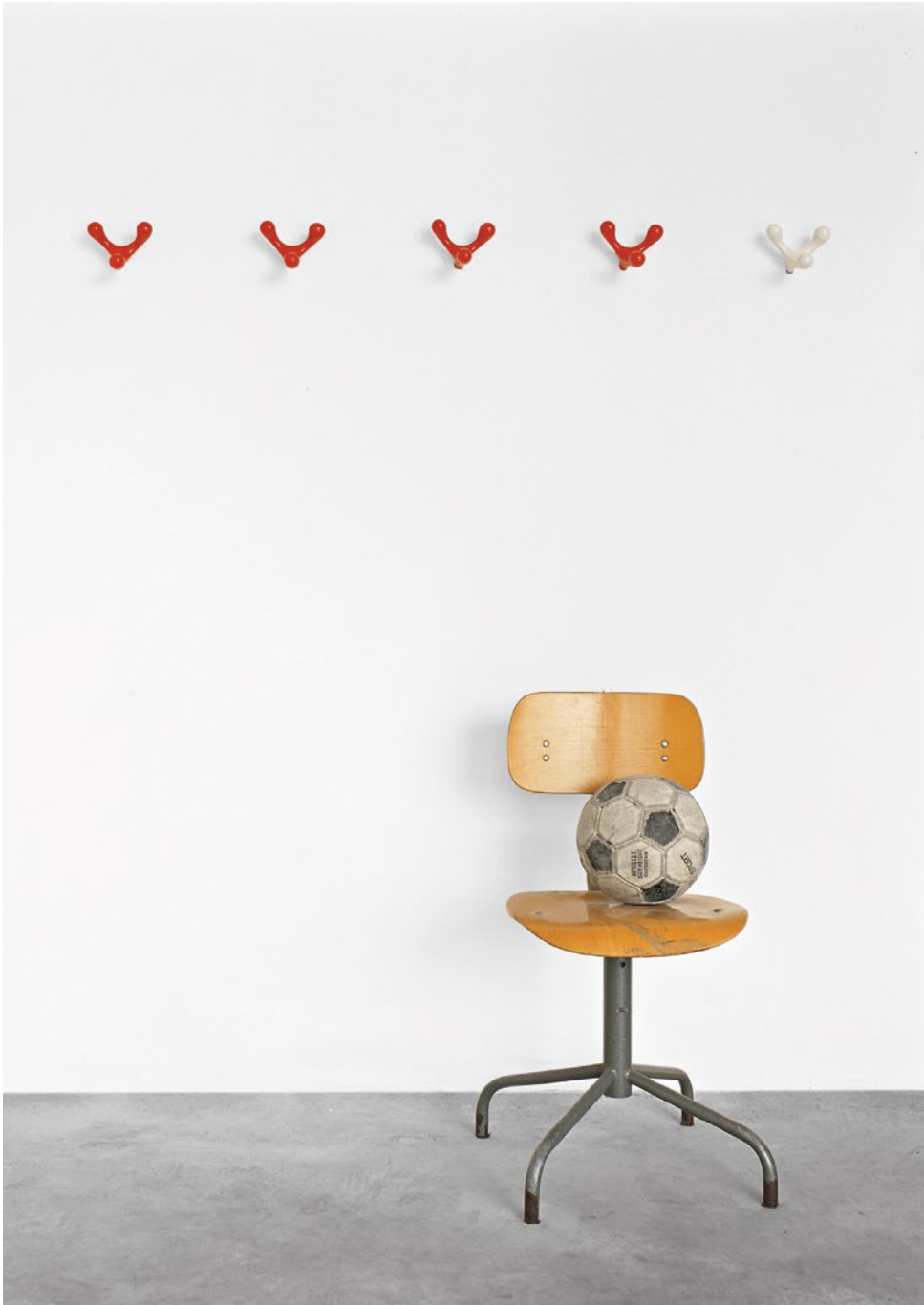

Hang—Up coat hook
Aluminium lacquered



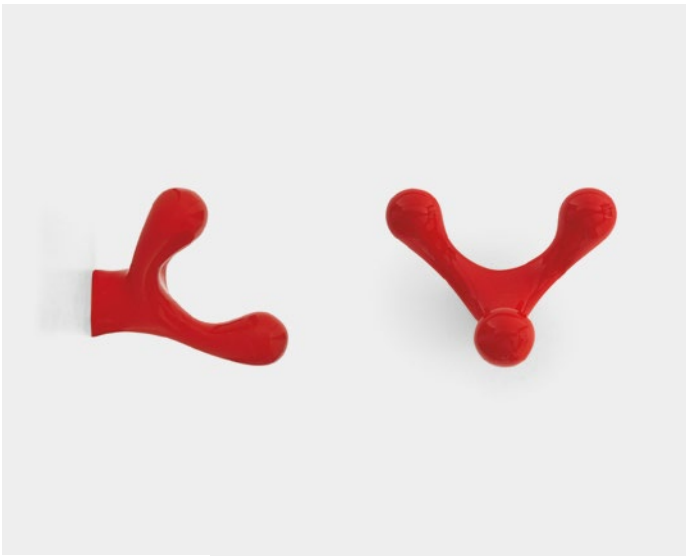

1

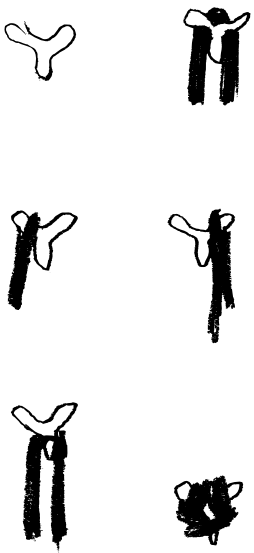

2

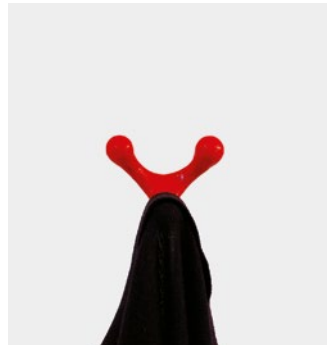

3

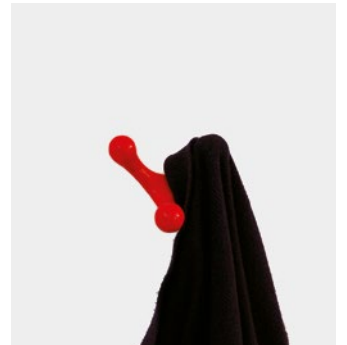

4



5

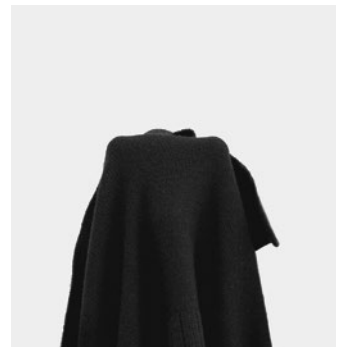

6

Hang—Up

DESIGN BY SALVATORE+MARIE, 2006

I Hang—Up è un appendiabiti in fusione di alluminio dal design allegro e funzionale. Un elemento d'arredo insolito e vivace, che quando è in uso sostiene con praticità indumenti e accessori senza rovinarli né deformati grazie alla sua forma sinuosa e organica priva di spigoli. Disegnato da Salvatore+Marie, realizzato artigianalmente, Hang—Up è disponibile con finitura spazzolata o lucida nelle varianti bianca o rossa, che ricorda un corallo. Si usa dappertutto: dall'ingresso alla camera dei ragazzi, in casa come in ufficio.

EN Hang—Up is a die-cast aluminium coat hook with a playful and functional design. It is an unusual and striking furnishing object, which conveniently hangs clothes and accessories without ruining or deforming them thanks to its sinuous and organic shape without sharp edges. Designed by Salvatore+Marie and handcrafted, Hang—Up is available with a white or red brushed or gloss finish, reminiscent of coral. It can be used anywhere: in the entrance hall, the children's room, the home or the office.

DE Hang—Up ist ein Kleiderhaken aus Aluminiumguss mit heiterem und zweckmäßigem Design. Ein ungewöhnliches und lebhaftes Einrichtungselement, das dank seiner gerundeten und organischen Form ohne Ecken und Kanten Kleidungsstücke und Accessoires trägt, ohne diese zu beschädigen oder zu verformen. Der handwerklich hergestellte

Kleiderhaken Hang—Up nach einem Entwurf von Salvatore+Marie ist in gebürsteter oder glänzender Ausführung in den Varianten Weiß oder Korallrot erhältlich. Er lässt sich wirklich überall einsetzen: von der Diele bis zum Kinderzimmer, im privatem Heim genauso wie im Büro.

ES Hang—Up es un colgador de fusión de aluminio de diseño alegre y funcional. Un elemento decorativo insólito y alegre que durante el uso sostiene con practicidad las prendas y los accesorios sin estropearlos ni deformatos, gracias a su forma sinuosa y orgánica desprovista de esquinas. Diseñado por Salvatore+Marie y realizado artesanalmente, Hang—Up está disponible con acabado cepillado o brillante en las variantes blanca o roja, semejante al coral. Puede utilizarse en cualquier lugar: del vestíbulo al dormitorio de los chicos, tanto en casa como en la oficina.

FR Hang—Up est une patère en fonte d'aluminium au design gai et fonctionnel. Un élément décoratif, insolite et amusant, qui sert à pendre des vêtements ou des accessoires sans les abîmer ni les déformer grâce à sa forme sinueuse et organique sans arêtes. Dessiné par Salvatore+Marie et réalisé artisanalement, Hang—Up existe avec une finition brossée ou brillante dans les coloris blanc ou rouge, qui rappelle un corail. Il s'installe n'importe où : dans l'entrée, dans la chambre des enfants, aussi bien à la maison qu'au bureau.

Sizes



L 12 P 11 H 10 cm
W 4 3/8" D 4 3/8" H 3 7/8"

Aluminium





1



2

Bureau

DESIGN BY BLUEZONE, 2004

La parola Bureau descrive alla perfezione questo elemento d'arredo creato da Bluezone pensando agli spazi di lavoro, perfetto in ufficio accanto alla scrivania ma ideale anche a casa, come complemento per l'home-office. Cassettiera metallica dalle linee impeccabili, Bureau è un parallelepipedo essenziale che si sposta agilmente grazie alle ruote. Resistente perché realizzato in metallo robusto e inalterabile, è dotato di una cassetta porta cancelleria e si può attrezzare con cassetti oppure con cassetti e classificatore. Bureau è disponibile nelle finiture bianco semi opaco, alluminio o nero satinato.

The word "Bureau" perfectly describes this piece of furniture created by Bluezone, bearing in mind workspaces. It is perfect in the office next to a desk and ideal in the home as an accessory for the home-office. A metal drawer unit with flawless lines, Bureau is a minimalist parallelepiped, which moves easily on castors. Made of strong unalterable metal, it is hardwearing and equipped with a stationery drawer and can be fitted with drawers only, or with drawers and a file sorter. Bureau is available with a semi-matt white, aluminium or satin black finish.

Das Wort Bureau beschreibt auf perfekte Weise dieses von Bluezone kreierte Einrichtungselement. Der Entwurf richtete sich dabei an Arbeitsräume als ideale Möbel neben dem Schreibtisch, es macht aber auch zu Hause

als Zusatzelement für das Home Office eine gute Figur. Der metallische Schubladenschrank Bureau mit makellosen Linien ist ein essenzieller Quader, der sich dank der Rollen mühelos verschieben lässt. Er ist aus robustem und besonders haltbarem Metall gefertigt, besitzt eine praktische Lade für Schreibutensilien und kann nur mit Schubladen oder mit Schubladen und Hängeregistratur ausgestattet werden. Bureau ist in den Ausführungen Weiß halbmatt, Aluminium oder Schwarz satiniert erhältlich.

La palabra Bureau describe a la perfección este elemento decorativo creado por Bluezone pensando en los espacios de trabajo, perfecto en la oficina al lado del escritorio o en casa, como complemento del estudio doméstico. Cajonera metálica de líneas impecables, Bureau es un paralelepípedo esencial provisto de ruedas que se desplaza con agilidad. Resistente, porque está realizado en metal robusto e inalterable, está dotado de un pequeño cajón para los artículos de papelería y puede equiparse solamente con cajones o con cajones y clasificador. Bureau está disponible en los acabados blanco semimate, aluminio o negro satinado.

Le mot Bureau décrit à la perfection ce meuble créé par Bluezone en pensant aux espaces de travail, parfait au bureau, mais également idéal à la maison comme complément pour l'home-office. Caisson à tiroirs en métal aux lignes impeccables, Bureau est un

Type



L 42 P 54 H 54 cm
W 16¹/₈" D 21¹/₂" H 21¹/₂"

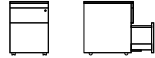

L 42 P 54 H 60 cm
W 16¹/₈" D 21¹/₂" H 23⁵/₈"



L 42 P 76 H 60 cm
W 16¹/₈" D 30" H 23⁵/₈"

Steel



parallélépipède épuré qui se déplace aisément grâce à ses roulettes. Résistant parce qu'il est réalisé en métal robuste et inaltérable, il est doté à l'intérieur d'un plumier et peut être aménagé avec des tiroirs simples ou pour dossiers suspendus. Bureau est décliné en blanc semi-mat, en aluminium ou en noir satiné.





Lips—R removable cushion
Upholstered Hero fabric

Rama chair - four legs
Wooden body

TNP table
Bistro



Lips—S removable cushion
Upholstered Field 2 fabric

Lips—R removable cushion
Back view



Lips-R



Lips-S



Lips-D

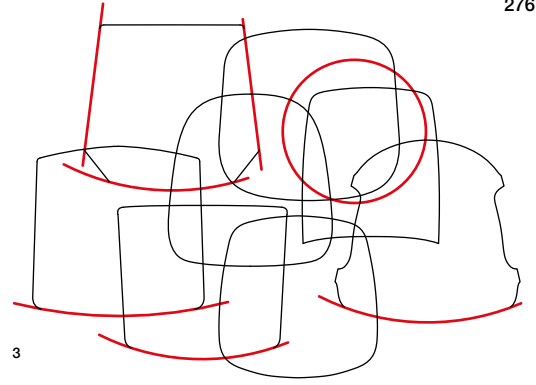

3



Fixing system

Seating & cushions



Colander



Compas



or



Elephant



or



Face



LP



or



Mem



Pikaia



Plana



Pulp



or



Rama



Sharky



Lips

DESIGN BY LUCIDIPEVERE, 2018

IT I cuscini Lips sono pensati per rendere ancora più comode le nostre sedie. Disegnati da LucidiPevere, hanno tre forme diverse – tonda, sagomata e rettangolare, quest'ultima specifica per la seduta Mem – per adattarsi a tutti i sedili, dal più piccolo al più ampio. Infinite le possibilità di rivestimento, un'ampia tavolozza che permette di abbinare a piacere i colori a quelli delle sedie. I cuscini Lips sono caratterizzati dal bordo nero e da una cucitura centrale, che fa sembrare la variante tonda una bocca. La superficie inferiore è rivestita di materiale antiscivolo, un dettaglio tecnico che li rende ancora più confortevoli.

EN Lips cushions have been designed to make our chairs even more comfortable. Designed by LucidiPevere, they come in three different shapes – round, shaped and rectangular, the latter specifically designed for the Mem chair – to adapt to all chairs, from the smallest to the largest. Countless options are available for upholstery, whereas a wide variety of colours allows you to match the colours with chairs as you please. Lips cushions feature a black trim and a central seam, which makes the round version look like a mouth. The lower surface is covered with non-slip material, a technical detail that makes them even more comfortable.

DE Die Kissen Lips sind dafür da, um unsere Stühle noch bequemer zu machen. Sie wurden von LucidiPevere entworfen und haben drei unterschiedliche Formen, rund, fassoniert und

rechteckig, letztere speziell für das Sitzmöbel Mem, um sich allen Sitzflächen, von der kleinsten bis zur größten, anzupassen. Es gibt unzählige Bezugsvarianten und eine reichhaltige Farbpalette, die es Ihnen ermöglicht, die Farben ganz nach Belieben mit jenen der Stühle zu kombinieren. Die Kissen Lips zeichnen sich durch eine schwarze Einfassung und eine Mittelnaht aus, die an einen runden Mund erinnert. Die Unterseite ist mit rutschfestem Material bezogen, ein technisches Detail, das die Kissen noch komfortabler macht.

ES Los cojines Lips han sido concebidos para hacer todavía más cómodas nuestras sillas. Diseñados por LucidiPevere, están disponibles con tres formas distintas, redonda, perfilada y rectangular —la última específica para la silla Mem— que se adaptan a todos los asientos: del más pequeño al más grande. Las posibilidades de revestimiento son infinitas: su amplia paleta cromática permite combinar a voluntad sus colores con los de las sillas. Los cojines Lips se caracterizan por su borde negro y por su costura central, que en la variante redonda produce el efecto de una boca. La superficie inferior está revestida en material antideslizante, un detalle técnico que aumenta todavía más su confort.

FR Les coussins Lips ont été créés pour que nos chaises soient encore plus confortables. Dessinés par LucidiPevere, ils ont trois différentes formes – ronde, galbée et rectangulaire (cette dernière spécifique pour le

modèle Mem) – afin de s'adapter aux assises, des plus petites aux plus grandes. Les revêtements possibles sont infinis grâce au vaste choix de couleurs permettant de les associer aux chaises selon les goûts de chacun. Les coussins Lips se distinguent par un passepoil noir et par une couture centrale qui fait ressembler la version ronde à une bouche. La face inférieure est revêtue d'un matériau antiglisse, un plus pour un confort sans égal.

Type



R
Ø 38 H 5 cm
Ø 15" H 2"



S
L 40 P 40 H 5 cm
W 15^{5/8}" D 15^{5/8}" H 2"



D
L 46 P 60 H 5 cm
W 18^{1/8}" D 23^{5/8}" H 2"

Field 2 (Kvadrat®) fabric



30 colours



Type



45 x 45 cm
17^{5/8}" x 17^{5/8}"



65 x 55 cm
25^{5/8}" x 21^{5/8}"

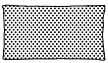

75 x 40 cm
29^{1/8}" x 15^{5/8}"

Sofa cushions

DESIGN BY BLUEZONE, 2018

IT Morbidi e confortevoli, i cuscini sono anche molto decorativi. Soffici per l'imbottitura in vera piuma d'oca, trasformano con colori e texture gli arredi cui si accompagnano, creando bellissime palette di colori a contrasto o in tinta. I nostri cuscini, disponibili in tre misure, sono universali: perfetti sul divano, sono ideali ovunque sia necessario un tocco di comfort in più.

EN Soft and comfortable, these cushions are also highly decorative. Soft thanks to their genuine goose down padding, with their colours and textures they transform the furniture that they adorn, creating a beautiful splash of contrasting or matching colours. Our cushions, available in three sizes, are universal: perfect on the sofa, they are ideal wherever a little comfort is required.

DE Diese weichen und bequemen Kissen sind auch noch sehr dekorativ. Flauschig durch die Füllung aus echter Gänsedaune verwandeln sie mit ihren Farben und Texturen die Möbelemente und schaffen wunderschöne Farbpaletten aus kontrastierenden oder abgestimmten Tönen. Unsere in drei Größen erhältlichen Kissen sind richtige Alleskönner: Perfekt auf dem Sofa und überall ideal, wo ein Extrahauch von Komfort benötigt wird.

ES Suaves y confortables, los cojines son también muy decorativos. Provisos de un suave relleno de auténtica pluma de oca, con sus colores y texturas transforman los muebles que

los acompañan creando magníficas paletas de colores a juego o en contraste. Nuestros cojines, disponibles en tres medidas, son universales: perfectos en el sofá, son ideales para todos los lugares que requieren un toque adicional de confort.

FR Moelleux grâce aux garnissages en plumes d'oie véritables et confortables, les coussins sont également très décoratifs. En effet, avec leurs couleurs et leurs tissus, ils transforment les éléments qu'ils accompagnent en créant de très belles palettes contrastantes ou assorties. Nos coussins déclinés en trois dimensions au choix sont universels: parfaits sur le canapé, ils s'installent là où ils sont nécessaires pour un meilleur confort.

Divina Melange 2 (Kvadrat®) fabric



Divina MD (Kvadrat®) fabric

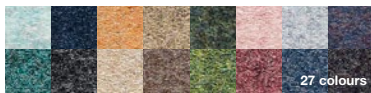

Hero (Kvadrat®) fabric

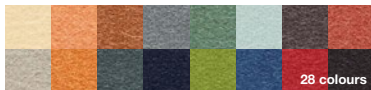

Steelcut Trio 3 (Kvadrat®) fabric

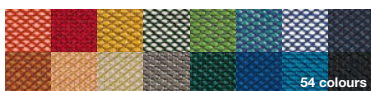

Field 2 (Kvadrat®) fabric



Curmi (Torri Lana®) fabric

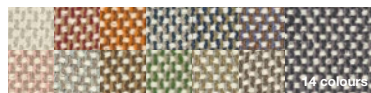

Regal (Erimiti®) velvet fabric



Scuba (Kvadrat®) fabric



Extrema AU (Flukso®) synthetic leather

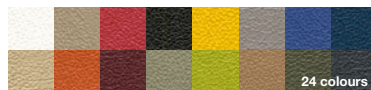

Coast (Elmo®) pigmented & printed leather

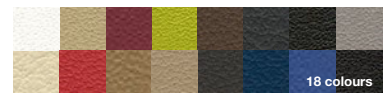

Elmosoft (Elmo®) semi-aniline leather



Elmotique (Elmo®) aniline leather





Constellations occasional table
H. 61-41 cm

Tenso sofa
Upholstered Curmi fabric

Mustache—GA rug
GA-03 green

Mustache

DESIGN BY PAOLO ZANI, 2018

IT Mustache è una linea di tappeti disegnata da Paolo Zani. Nata per rispondere alle esigenze dell'outdoor, si è evoluta in una serie di complementi versatili adatti a qualsiasi spazio. Caratterizzati da una tramatura mélange con bordature in diversi colori e frange, i tappeti sono fatti con il telaio a mano: una lavorazione di pregio artigianale e qualità sartoriale che li rende uno diverso dall'altro. Realizzati con un filato in fibra di polipropilene, i tappeti Mustache sono disponibili con tre disegni a due o più colori, in due dimensioni standard o su richiesta. Sono molto resistenti, anche quando esposti ai raggi solari o all'umidità.

EN **Mustache is a collection of carpets designed by Paolo Zani. Created to meet the needs of outdoor spaces, it has evolved into a range of versatile furnishing accessories ideal for any space. Featuring a melange weave with edge trims in different colours and fringes, the carpets are woven on handlooms: such fine craftsmanship and tailored quality makes each one of them unique. Made from a polypropylene fibre yarn, Mustache carpets are available in three designs in two or more colours and in two standard sizes, or can be customised on request. They are highly resistant, even when exposed to sunlight or humidity.**

DE Mustache ist eine von Paolo Zani entworfene Teppichlinie. Ursprünglich als Antwort für die Anforderungen im Outdoor-Bereich gedacht, hat

sich die Linie zu einer Reihe von vielseitigen und für jede Räumlichkeit geeigneten Einrichtungselementen weiterentwickelt. Die Teppiche zeichnen sich durch ein Gewebe mit Mélange-Effekt und Kettelung in verschiedenen Farben und Fransen aus und werden von Hand am Rahmen gewebt: Eine mit großem handwerklichem Können ausgeführte Verarbeitung, die jeden Teppich zu einem unnachahmlichen Einzelstück macht. Die mit Garn aus Polypropylen hergestellten Teppiche Mustache stehen mit drei Mustern mit zwei oder mehreren Farben sowie in zwei Standardgrößen oder mit Maß nach Anfrage zur Auswahl. Sie sind sehr widerstandsfähig, auch wenn sie Sonnenstrahlen oder Feuchtigkeit ausgesetzt sind.

ES Mustache es una línea de alfombras diseñada por Paolo Zani. Nacida para responder a las necesidades de los ambientes exteriores, ha evolucionado dando lugar a una serie de complementos versátiles adecuados para cualquier espacio. Caracterizadas por una trama melange con ribeteados de distintos colores y flecos, las alfombras están realizadas en telar a mano: una confección de alto valor artesanal y de calidad sartorial que confiere un carácter exclusivo a cada pieza. Realizadas con un hilado de fibra de polipropileno, las alfombras Mustache están disponibles con tres motivos de dos o varios colores, en los dos tamaños estándar o bajo demanda. Son muy resistentes, incluso cuando se exponen a los rayos solares o la humedad.

ES Mustache est une ligne de tapis dessinée par Paolo Zani. Créée pour répondre aux besoins de l'extérieur, elle s'est ensuite développée en une série de compléments adaptés à n'importe quel espace. Caractérisés par un tissage mélangé avec bordage en divers coloris et franges, les tapis sont tissés à la main sur un métier à tisser : une réalisation offrant la qualité du travail artisanal et permettant d'avoir des tapis tous différents les uns des autres. Fabriqués avec un fil en fibre de polypropylène, les tapis Mustache existent avec trois dessins à deux ou plusieurs couleurs, dans deux dimensions standard ou sur mesure. Ils sont très résistants même s'ils sont exposés au soleil ou à l'humidité.

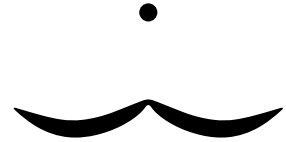

Mustache logo





1

Il simbolo grafico della linea Mustache si ispira all'India, civiltà di millenaria tradizione culturale, artistica e artigianale. Qui, nella regione di Varanasi, nascono questi tappeti nell'ambito del programma STEP che certifica: il rispetto dei diritti delle lavoratrici e dei lavoratori, la tutela della loro salute e sicurezza, la lotta contro il lavoro minorile illegale, la discriminazione, il lavoro forzato e la promozione di processi produttivi ecosostenibili. Vengono inoltre garantiti compensi adeguati secondo i principi del commercio equo e solidale. Questi concetti sono elencati su un'etichetta che accompagna ogni tappeto. I tappeti sono sottoposti inoltre a continui controlli sul posto per garantirne il valore etico oltre che estetico. I tappeti Mustache sono realizzati con filati di polipropilene di alta qualità, adatti sia all'utilizzo outdoor che in interni. L'unica accortezza richiesta è di utilizzare una rete antiscivolo se il pavimento è molto liscio, e nel caso sia dotato di sistema di riscaldamento radiante, verificare che nel tempo non aderisca alla superficie su cui è appoggiato. All'aria aperta si consiglia di non appoggiare per lungo tempo il tappeto direttamente sulla terra o sull'erba. In caso di pioggia o umidità, per facilitare l'asciugatura, meglio sollevare lievemente il tappeto. La pulizia ordinaria andrebbe effettuata almeno una volta a settimana, con un aspiratore dotato di spazzola morbida, mentre per una pulizia più profonda si possono usare acqua fredda e detersivo neutro. Rimuovere immediatamente le macchie di liquidi e tamponarle con un panno pulito, senza strofinare o bagnare l'area. Quando la macchia è assorbita, pulire con un panno e detersivo neutro diluito in acqua, iniziando dai bordi verso il centro, poi sciacquare e lasciare asciugare. Ripetere l'operazione in caso di macchie resistenti. Togliere le macchie di materiale secco con una spazzola morbida o il bordo di un cucchiaino. Evitare spazzole dure, utensili abrasivi, candeggianti e solventi, lavaggi a secco e idropulitrici.

EN The graphic symbol of the Mustache collection is inspired by India, a civilization with centuries-old cultural, artistic and artisan traditions. Here, in the Varanasi region, these carpets are made as part of the STEP programme, which supports: respect for the rights of male and female workers and the protection of their health and safety, the prevention of illegal child labour, discrimination, forced labour and the promotion of eco-sustainable production processes. Adequate remuneration is also guaranteed in accordance with the principles of fair trade. These principles are listed on a label that accompanies each carpet. The carpets also undergo on-site checks to ensure their ethical and aesthetic value. Mustache carpets are made of high-quality polypropylene yarns, ideal for both indoor and outdoor use. The only precaution required is to use non-slip mesh if the floor is very smooth. And if it is has a radiant heating system, it is necessary to check, over time,

that it does not stick to the surface where it has been placed. When used outdoors, we do not recommend placing the carpet directly on the ground or on grass for a long period. When it has rained or humidity is high, it is better to slightly raise the carpet to facilitate drying. Routine cleaning should be carried out at least once a week with a vacuum cleaner with a soft brush, whereas cold water and a mild detergent can be used for more thorough cleaning. Immediately remove any stains caused by liquids and dab them with a clean cloth, without rubbing or wetting the area. When the stain has been absorbed, clean with a cloth and a mild detergent diluted in water, starting from the edges towards the centre, then rinse and allow to dry. Repeat the procedure for stubborn stains. Remove any stains caused by dry materials with a soft brush or the rim of a spoon. Avoid using hard brushes, abrasive tools, bleaching agents and solvents, dry cleaning and high-pressure cleaners.

Das grafische Symbol der Linie Mustache lässt sich von Indien und dessen Zivilisation mit tausendjähriger kultureller, künstlerischer und handwerklicher Tradition inspirieren. Hier in der Region von Varanasi entstehen diese Teppiche im Rahmen des Programms STEP, dessen Label folgende Standards bescheinigt: Einhaltung der Rechte der Teppichknüpfer/-innen, Gesundheitsschutz und Sicherheit am Arbeitsplatz, Kampf gegen missbräuchliche Kinderarbeit, Diskriminierung und Zwangsarbeit sowie die Förderung von ökologisch verträglichen Herstellungsverfahren. Darüber hinaus werden laut den Vorgaben des Fairen Handels gerechte Löhne gewährleistet. Alle diese Punkte sind auf einem Etikett angeführt, das jedem Teppich beiliegt. Die Teppiche werden außerdem ständigen Kontrollen vor Ort unterzogen, um neben dem ästhetischen auch den ethischen Wert zu garantieren. Die Teppiche Mustache werden mit hochwertigen Polypropylengarnen angefertigt, die sich sowohl für den Innen- als auch für den Außenbereich eignen. Die einzige Vorsichtsmaßnahme ist die Verwendung einer Antirutschmatte, wenn der Boden sehr glatt sein sollte. Stellen Sie bei einer vorhandenen Fußbodenheizung außerdem sicher, dass der Teppich nicht auf der Oberfläche festhaftet. Im Freien wird empfohlen, den Teppich nicht für längere Zeit direkt auf die Erde oder auf das Gras zu legen. Heben Sie den Teppich bei Regen oder Feuchtigkeit leicht an, um das Trocknen zu erleichtern. Reinigen Sie den Teppich mindestens einmal pro Woche mit der weichen Bürste eines Staubsaugers, bei stärkerer Verschmutzung können kaltes Wasser und ein neutrales Reinigungsmittel verwendet werden. Eventuelle Flüssigkeiten müssen sofort mit einem sauberen Tuch abgetupft werden, ohne dabei die Stelle zu reiben oder zu befeuchten. Wenn der Fleck aufgesaugt ist, reinigen Sie die Stelle mit einem Tuch und mit Wasser verdünnten Reinigungsmittel. Dabei immer von den Rändern aus zur Mitte wischen, mit klarem Wasser nachspülen und trocknen

lassen. Bei hartnäckigen Flecken den Vorgang wiederholen. Entfernen Sie trockene Schmutzreste mit einer weichen Bürste oder dem Rand eines Löffels. Vermeiden Sie den Einsatz von harten Bürsten, Reibschwämmen, Bleich- und Lösungsmittel oder Hochdruckreinigern und bringen Sie den Teppich nicht in die chemische Reinigung.

El símbolo gráfico de la línea Mustache se inspira en la India, una civilización de tradición cultural, artística y artesanal milenaria. Las alfombras se crean en la región de Varanasi en el ámbito del programa STEP, que certifica el respeto de los derechos de los trabajadores y las trabajadoras, la tutela de su salud y seguridad, la lucha contra el trabajo ilegal de menores, la discriminación y los trabajos forzados y la promoción de procesos productivos ecosostenibles. También se garantizan retribuciones adecuadas, de acuerdo con los principios del comercio justo y solidario. Estos conceptos aparecen mencionados en la etiqueta que acompaña cada alfombra. Las alfombras son sometidas a continuos controles en situ para garantizar su valor ético y estético. Las alfombras Mustache están realizadas con hilados de polipropileno de alta calidad, idóneos para el uso en ambientes exteriores e interiores. Solo es necesario acordarse de utilizar una red antideslizante si el suelo es muy liso o asegurarse de que no se adhieran a la superficie de apoyo en presencia de sistemas de calefacción radiante. Al aire libre, se aconseja no mantener apoyada la alfombra sobre la tierra o la hierba durante demasiado tiempo. En caso de lluvia o humedad, es preferible elevarla ligeramente para facilitar el secado. La limpieza rutinaria debe efectuarse al menos una vez por semana con un aspirador dotado de cepillo suave, mientras que para efectuar una limpieza más profunda se puede utilizar agua fría con un detergente neutro. Eliminar inmediatamente las manchas de líquidos y secar con delicadeza presionando con un paño limpio, sin frotar ni mojar el área afectada. Una vez que se ha absorbido la mancha, limpiar con un paño y detergente neutro diluido en agua, empezando por los bordes y siguiendo hacia el centro. A continuación, aclarar y dejar secar. Repetir la operación en caso de manchas resistentes. Quitar las manchas de material seco con un cepillo suave o con el borde de una cuchara. Evitar el uso de cepillos duros, de utensilios abrasivos y de blanqueadores o solventes, así como el lavado en seco o con hidrolimpiadoras.

Le symbole graphique de la ligne Mustache s'inspire de l'Inde dont la civilisation a une tradition culturelle, artistique et artisanale millénaire. C'est dans la région de Varanasi que sont créés ces tapis dans le cadre du programme STEP qui certifie: le respect des droits des travailleuses et des travailleurs, la protection de leur santé et de leur sécurité, la lutte contre le travail illégal des enfants, contre la discrimination et contre le travail forcé et la promotion de processus de production éco-durables. En outre, des rémunérations adéquates sont assurées selon les principes du commerce équitable. Tous ces concepts sont indiqués sur une étiquette qui accompagne chaque tapis. Les tapis sont également soumis à des contrôles continus sur place pour en assurer la valeur éthique et esthétique. Les tapis Mustache sont réalisés avec des fils de polypropylène de haute qualité, adaptés à un usage tant extérieur qu'intérieur. L'unique précaution requise est d'utiliser un sous-tapis antiglisse antidérapant au cas où le sol serait très lisse. En cas de chauffage radiant, il faudra également surveiller, après un certain temps, que celui-ci n'adhère pas à la surface sur laquelle il pose. Si le tapis

est utilisé à l'extérieur, il est recommandé d'éviter de le poser directement sur la terre ou sur l'herbe pendant une longue période de temps. En cas de pluie ou de temps humide, il est préférable de le soulever légèrement afin qu'il sèche plus facilement. L'entretien ordinaire devrait s'effectuer au moins une fois par semaine à l'aide d'un aspirateur doté d'une brosse souple alors que, pour un nettoyage plus en profondeur, on pourra utiliser de l'eau froide et un détergent neutre. Éliminer immédiatement les taches liquides et les tamponner avec un chiffon propre sans frotter ni mouiller la surface. Si le tapis a déjà absorbé la tache, le nettoyer avec un chiffon et un détergent neutre dilué dans de l'eau, en partant du bord vers le centre du tapis, puis rincer et laisser sécher. Répéter l'opération en cas de taches plus tenaces. Enlever les taches épaisses, solides ou pâteuses à l'aide d'une brosse souple ou du bord arrondi d'une cuillère. Ne pas utiliser de brosse dure, d'instruments abrasifs, d'eau de Javel, de solvants, de nettoyeur haute pression et ne pas effectuer de nettoyage à sec.

- 1  **Wage agreements are observed; living wages are aimed for**
-  **Health and safety of workers is assured**
-  **Workers have the right to organise and to collective bargaining**
-  **Discrimination of any kind is not tolerable**
-  **Child labour is prohibited**
-  **Inhumane treatment and sexual harassment are not tolerated**
-  **Forced and bonded labour are forbidden**
-  **Maximum working hours and rest periods are followed**
-  **Environmental impact is reduced**
-  **STEP gets unhindered access for audits**

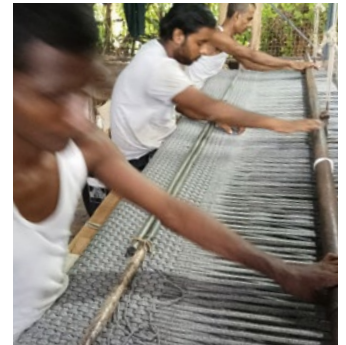

2



3



DESIGNED RESPONSIBLY
www.label-step.org





GA-01 charcoal



GA-02 terracotta brown



GA-03 green

Mustache – GA

DESIGN BY PAOLO ZANI, 2018

IT

Filato: 100% polipropilene
 Tecnica: tessuto a mano su telaio
 Spessore: ≈1 cm
 Peso: ≈2,75 kg/m²
 Resistente all'acqua
 Inalterabilità colore UV interno: 8/8
 Inalterabilità colore UV esterno: 4-5/8
 Inalterabilità colore al lavaggio: 5/5
 Testato: ISO 105B02 – ISO 105B04
 Dimensioni (frange escluse):
 standard 200x300 – 300x400 cm
 su misura a richiesta
 Tolleranza dimensionale: ± 3%

EN

Yarn: 100% polypropylene
Weaving: handwoven on a loom
Thickness: ≈1 cm
Weight: ≈2.75 kg/m²
Water resistant
Indoor UV colour fastness: 8/8
Outdoor UV colour fastness: 4-5/8
Washing colour fastness: 5/5
Tested: ISO 105B02 – ISO 105B04
Sizes (fringes not included):
standard 200x300 – 300x400 cm
custom-sized on demand
Size tolerance: ± 3%

DE

Garn: 100% Polypropylen
 Webtechnik: Am Rahmen handgewebt
 Stärke: ≈1 cm
 Gewicht: ≈2,75 kg/m²
 Wasserfest
 UV-Farbbeständigkeit im Innenbereich: 8/8
 UV-Farbbeständigkeit im Außenbereich: 4-5/8
 Farbbeständigkeit bei der Wäsche: 5/5
 Geprüft: ISO 105B02 – ISO 105B04
 Maße (inklusive Fransen):
 Standard 200x300 – 300x400 cm
 nach Maß auf Anfrage
 Größertoleranz: ± 3%

ES

Hilado: polipropileno 100%
 Técnica: tejido a mano en telar
 Espesor: ≈1 cm
 Peso: ≈2,75 kg/m²
 Resistente al agua
 Solidez del color UV interno: 8/8
 Solidez del color UV externo: 4-5/8
 Solidez del color al lavado: 5/5
 Probado: ISO 105B02 – ISO 105B04
 Dimensiones (sin incluir los flecos):
 estándar 200x300 – 300x400 cm
 a medida bajo pedido
 Tolerancia dimensional: ± 3%

EB

Fil: 100% polypropylène
 Technique: tissé main sur métier à tisser
 Épaisseur: ≈1 cm
 Poids: ≈2,75 kg/m²
 Résistant à l'eau
 Solidité des couleurs aux UV à l'intérieur: 8/8
 Solidité des couleurs aux UV à l'extérieur: 4-5/8
 Solidité des couleurs au lavage: 5/5
 Testé: ISO 105B02 – ISO 105B04
 Dimensions (hors franges):
 standard 200x300 – 300x400 cm
 sur mesure sur commande
 Tolérance des dimensions: ± 3%

Sizes

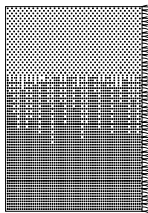

Small
 200 x 300 cm
 78⁵/₈" x 118¹/₈"

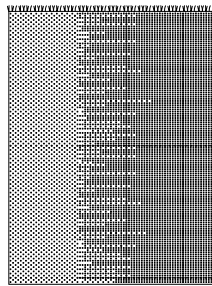

Large
 300 x 400 cm
 118¹/₈" x 157⁴/₈"

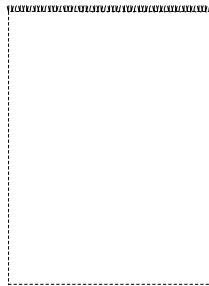

Custom

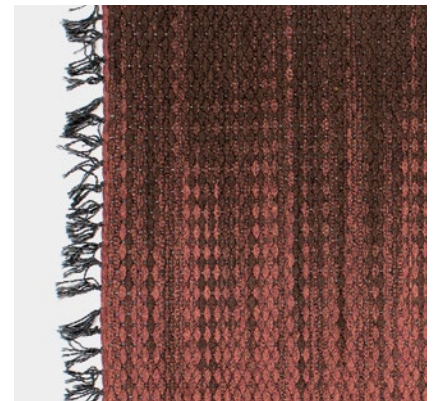



Mustache—RE rug
RE-02 terracotta brown

Elephant occasional table
Pure-white laminate top

Brioni large lounge chair
Outdoor version



Mustache—SA rug
SA-03 terracotta brown

Tuile 2-seat sofa
Upholstered Steelcut Trio 3 fabric



RE-01 canvas



RE-02 terracotta brown



RE-03 denim

Mustache – RE

DESIGN BY PAOLO ZANI, 2018

IT

Filato: 100% polipropilene
 Tecnica: tessuto a mano su telaio
 Spessore: ≈0,5 cm
 Peso: ≈1,40 kg/m²
 Resistente all'acqua
 Inalterabilità colore UV interno: 8/8
 Inalterabilità colore UV esterno: 4-5/8
 Inalterabilità colore al lavaggio: 5/5
 Testato: ISO 105B02 – ISO 105B04
 Dimensioni (frange escluse):
 standard 200x300 – 300x400 cm
 su misura a richiesta
 Tolleranza dimensionale: ± 3%

EN

Yarn: 100% polypropylene
Weaving: handwoven on a loom
Thickness: ≈0.5 cm
Weight: ≈1.40 kg/m²
Water resistant
Indoor UV colour fastness: 8/8
Outdoor UV colour fastness: 4-5/8
Washing colour fastness: 5/5
Tested: ISO 105B02 – ISO 105B04
Sizes (fringes not included):
standard 200x300 – 300x400 cm
custom-sized on demand
Size tolerance: ± 3%

DE

Garn: 100% Polypropylen
 Webtechnik: Am Rahmen handgewebt
 Stärke: ≈0,5 cm
 Gewicht: ≈1,40 kg/m²
 Wasserfest
 UV-Farbbeständigkeit im Innenbereich: 8/8
 UV-Farbbeständigkeit im Außenbereich: 4-5/8
 Farbbeständigkeit bei der Wäsche: 5/5
 Geprüft: ISO 105B02 – ISO 105B04
 Maße (inklusive Fransen):
 Standard 200x300 – 300x400 cm
 nach Maß auf Anfrage
 Größertoleranz: ± 3%

ES

Hilado: polipropileno 100%
 Técnica: tejido a mano en telar
 Espesor: ≈0,5 cm
 Peso: ≈1,40 kg/m²
 Resistente al agua
 Solidez del color UV interno: 8/8
 Solidez del color UV externo: 4-5/8
 Solidez del color al lavado: 5/5
 Probado: ISO 105B02 – ISO 105B04
 Dimensiones (sin incluir los flecos):
 estándar 200x300 – 300x400 cm
 a medida bajo pedido
 Tolerancia dimensional: ± 3%

EB

Fil: 100% polypropylène
 Technique: tissé main sur métier à tisser
 Épaisseur: ≈0,5 cm
 Poids: ≈1,40 kg/m²
 Résistant à l'eau
 Solidité des couleurs aux UV à l'intérieur: 8/8
 Solidité des couleurs aux UV à l'extérieur: 4-5/8
 Solidité des couleurs au lavage: 5/5
 Testé: ISO 105B02 – ISO 105B04
 Dimensions (hors franges):
 standard 200x300 – 300x400 cm
 sur mesure sur commande
 Tolérance des dimensions: ± 3%

Sizes

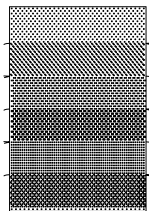

Small
 200 x 300 cm
 78^{5/8}" x 118^{1/8}"

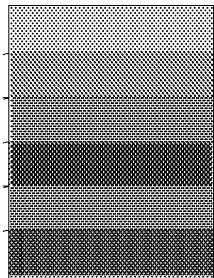

Large
 300 x 400 cm
 118^{1/8}" x 157^{4/8}"

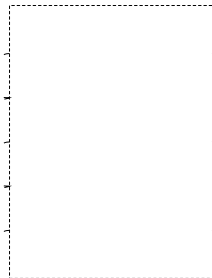

Custom

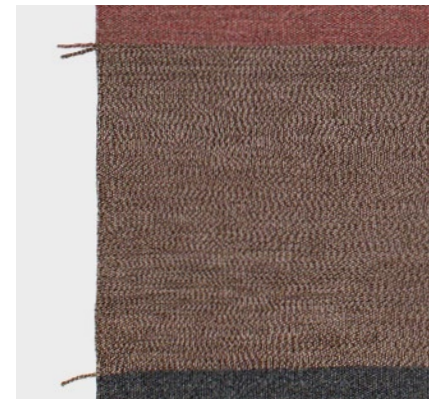

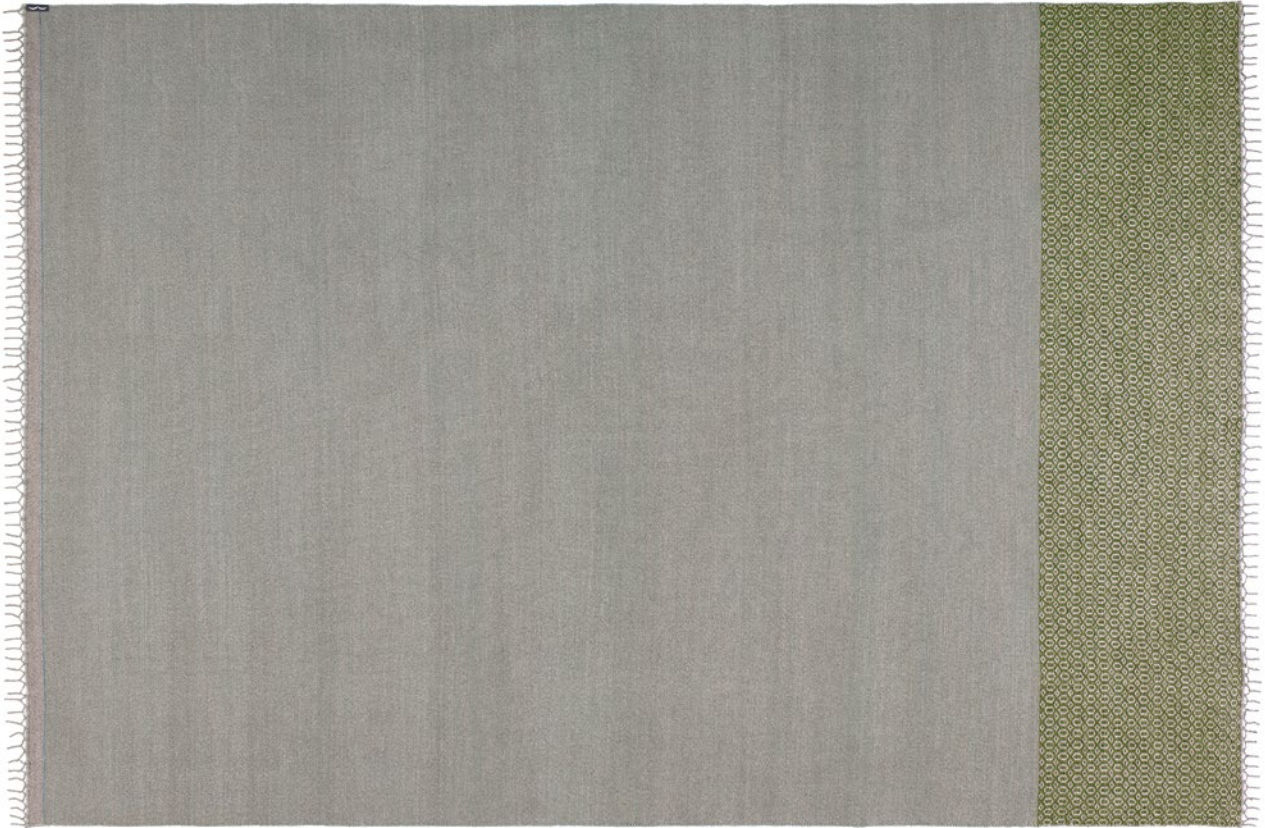

SA-01 green



SA-02 charcoal

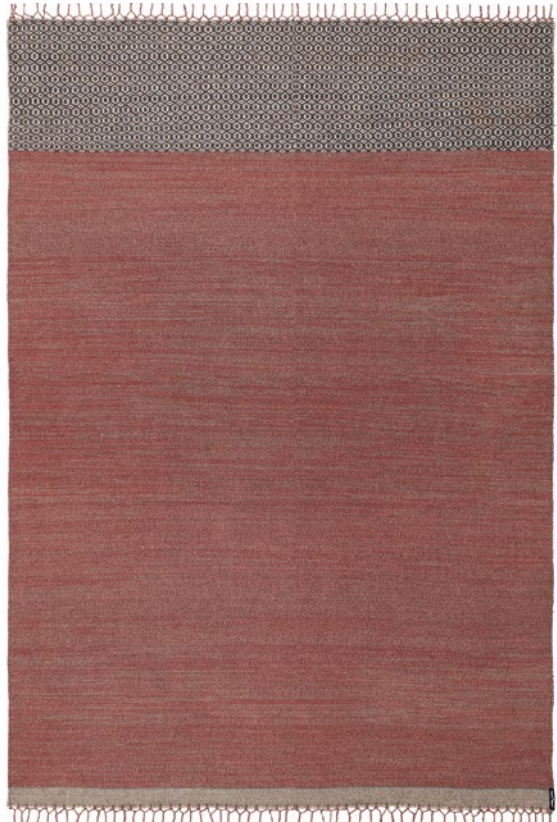

SA-03 terracotta brown

Mustache – SA

DESIGN BY PAOLO ZANI, 2018

IT

Filato: 100% polipropilene
 Tecnica: tessuto a mano su telaio
 Spessore: ≈0,5 cm
 Peso: ≈1,20 kg/m²
 Resistente all'acqua
 Inalterabilità colore UV interno: 8/8
 Inalterabilità colore UV esterno: 4-5/8
 Inalterabilità colore al lavaggio: 5/5
 Testato: ISO 105B02 – ISO 105B04
 Dimensioni (frange escluse):
 standard 200x300 – 300x400 cm
 su misura a richiesta
 Tolleranza dimensionale: ± 3%

EN

Yarn: 100% polypropylene
Weaving: handwoven on a loom
Thickness: ≈0.5 cm
Weight: ≈1.20 kg/m²
Water resistant
Indoor UV colour fastness: 8/8
Outdoor UV colour fastness: 4-5/8
Washing colour fastness: 5/5
Tested: ISO 105B02 – ISO 105B04
Sizes (fringes not included):
standard 200x300 – 300x400 cm
custom-sized on demand
Size tolerance: ± 3%

DE

Garn: 100% Polypropylen
 Webtechnik: Am Rahmen handgewebt
 Stärke: ≈0,5 cm
 Gewicht: ≈1,20 kg/m²
 Wasserfest
 UV-Farbbeständigkeit im Innenbereich: 8/8
 UV-Farbbeständigkeit im Außenbereich: 4-5/8
 Farbbeständigkeit bei der Wäsche: 5/5
 Geprüft: ISO 105B02 – ISO 105B04
 Maße (inklusive Fransen):
 Standard 200x300 – 300x400 cm
 nach Maß auf Anfrage
 Größertoleranz: ± 3%

ES

Hilado: polipropileno 100%
 Técnica: tejido a mano en telar
 Espesor: ≈0,5 cm
 Peso: ≈1,20 kg/m²
 Resistente al agua
 Solidez del color UV interno: 8/8
 Solidez del color UV externo: 4-5/8
 Solidez del color al lavado: 5/5
 Probado: ISO 105B02 – ISO 105B04
 Dimensiones (sin incluir los flecos):
 estándar 200x300 – 300x400 cm
 a medida bajo pedido
 Tolerancia dimensional: ± 3%

EB

Fil: 100% polypropylène
 Technique: tissé main sur métier à tisser
 Épaisseur: ≈0,5 cm
 Poids: ≈1,20 kg/m²
 Résistant à l'eau
 Solidité des couleurs aux UV à l'intérieur: 8/8
 Solidité des couleurs aux UV à l'extérieur: 4-5/8
 Solidité des couleurs au lavage: 5/5
 Testé: ISO 105B02 – ISO 105B04
 Dimensions (hors franges):
 standard 200x300 – 300x400 cm
 sur mesure sur commande
 Tolérance des dimensions: ± 3%

Sizes

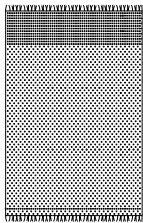

Small
 200 x 300 cm
 78⁵/₈" x 118¹/₈"

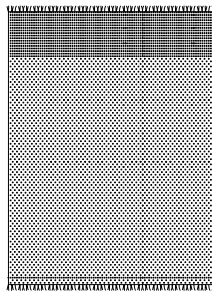

Large
 300 x 400 cm
 118¹/₈" x 157⁴/₈"

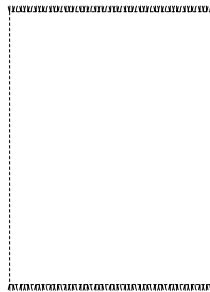

Custom





Mustache—RE rug
RE-01 Canvas

Made in Italy

Text by Chiara Alessi

^{IT} Se il made in Italy salverà gli italiani, gli italiani saranno capaci di salvare il made in Italy? Negli ultimi anni, la propagazione mediatica del made in Italy, la strumentalizzazione di quest'etichetta e la sua contemporanea e complicata burocratizzazione hanno in parte contribuito allo svuotamento di quel senso spesso immateriale, intangibile, valoriale che ha tradizionalmente disegnato nel nostro immaginario il ritratto del made in Italy. Come a dire che forse c'è stato un momento in cui anche senza spiegarcelo, tutti sapevamo che cosa intendere con made in Italy. Mentre oggi, forse, è necessario specificare qualche informazione in più da parte dei produttori e chiederla da parte dei consumatori/clienti. Non solo, infatti, per alcuni vuoti giuridici è possibile aggirare certi parametri quantitativi dichiarando come italiana anche una produzione che per buona parte viene da fuori, ma il fatto stesso di produrre in Italia, oggi, non garantisce più per se stesso di essere sinonimo di qualità. C'è made in Italy e made in Italy, insomma, e non è detto che tutto sia da salvare. E poi c'è l'idea che del made in Italy ha Kristalia e che difende in modo convincente da vent'anni.

Kristalia crede nel senso di ricapitolare le tappe principali del tragitto di un prodotto, offrirlo al proprio pubblico, convinta che la condivisione di questa storia ne certifichi il valore. Quella storia diventa così non solo un racconto aziendale, ma un tassello della narrazione della più interessante produzione italiana, delle sue specificità, e delle ragioni per cui crediamo davvero che questo sia uno degli esempi di made in Italy da salvare. Allora cominciamo col dire che la scelta dell'Italia, come luogo della produzione ma anche come luogo del reperimento di più del 90% delle materie prime, per Kristalia non dipende tanto dalle ragioni dei localismi o da bandiere campanilistiche, ma dal fatto che proprio l'Italia sia ritenuta ancora il migliore dei fornitori possibili nella stragrande maggioranza dei casi. Nel restante 10% dei casi, ci si rivolge ad altre eccellenze come ad esempio: il nord Europa per l'approvvigionamento dei tessuti, l'Austria per i laminati, la Germania per i materiali di ferramenta. Lo stesso vale per certi tipi di lavorazioni rispetto ai quali il territorio immediatamente circostante l'azienda detiene un primato di qualità impareggiabile. Questa prossimità, anche strategicamente, diventa essenziale per controllare i processi in modo costante e diretto nel raggio di pochi km, così come verificare i risultati dei semilavorati che arrivano. Ecco come il distretto si trasforma in servizio e come la rete locale riattiva uno scambio che ancora è possibile trovare solo in certi speciali territori italiani, di cui Prata senza dubbio rappresenta un epicentro dinamico. E ancora: pensando a un tema caldo di questi tempi come quello della manifattura italiana, Kristalia offre un buon esempio di quello che chiamiamo "alto artigianato industriale" tenendo insieme l'idea della manualità con quella della riproducibilità in serie, il concetto di alta specializzazione degli operatori con quello di produzione meccanica, l'efficienza con la slow production. Quanto alla creatività, infine, si cerca

di nuovo di scegliere il meglio, al di là della provenienza dei designer. La maggior parte delle aziende con una tradizione nel design italiano, da diversi anni, guardano anche o soprattutto all'estero per l'esplorazione dei talenti creativi. Allo stesso modo, Kristalia crede che proprio grazie alla sua forte identità culturale, nell'ambito del progetto l'impresa possa e debba dialogare con designer di tutte le lingue. Ormai da qualche anno succede che storiche aziende di design italiano si intendano di più con progettisti stranieri: questo accade perché la ricerca di un contributo creativo decisivo è incessante e non ammette confini, ma anche perché i migliori progettisti internazionali credono che sia ancora qui la patria della produzione di qualità e spesso è qui che vengono a cercare le storie più interessanti. A volte proprio come questa, home-made in Kristalia.

^{EN} If the "Made in Italy" concept can save the Italians, can the Italians save "Made in Italy"? In recent years, the coverage given to "Made in Italy" in the media, the exploitation of this tag and the complicated bureaucracy involved have partly contributed to the disappearance of that often immaterial, intangible and prestigious concept that has traditionally shaped our idea of "Made in Italy". We can say that perhaps there was a time when we all knew what was meant by "Made in Italy" even though it was never explained to us. Today, however, maybe manufacturers should be required to give more information, whereas consumers and customers should ask for more. Moreover, as a result of several legal loopholes, certain quantitative parameters can be bypassed and a product can be declared Italian even though most of its components come from abroad. But the very fact that something is made in Italy today is no longer a guarantee of it being synonymous with quality. In short, there is "Made in Italy" and "Made in Italy", and not necessarily should everything be preserved. What's more, Kristalia has been strongly defending its own concept of "Made in Italy" for twenty years. Kristalia believes in recapitulating the main steps in product phases, making its customers aware of this, convinced that sharing its path will be a guarantee of its value. Thus the product path not only belongs to the company but also becomes part of the most interesting Italian production, of its special features and the reasons why we really believe that this is an example of "Made in Italy" to be preserved. We can therefore say that for Kristalia the choice of Italy as a place of production and as a source of over 90% of its raw materials is not so much based on local interests or pride but on the fact that Italy is still considered the best supplier in the majority of cases. For the remaining 10%, we turn to other excellent sources, for example: northern Europe for the supply of fabrics, Austria for laminates and Germany for hardware fixings. The same applies to certain types of processing, with the area in the immediate vicinity of the company ranking high for

unbeatable quality. This proximity becomes essential, also in strategic terms, for the continuous control of processes within a range of just a few kilometres and for checking semi-finished products on arrival. This is how the district is transformed into a service and how the local network encourages an exchange that can still be found only in certain areas of Italy, and Prata di Pordenone is unquestionably a dynamic centre. Furthermore, when considering such a hot topic as Italian manufacturing Kristalia is a good example of what is called "high-end industrial craftsmanship", since it combines manual skills with standard production, the concept of highly specialised workers with mechanical production, and efficiency with slow production. Finally, with regard to creativity, once again, the company is trying to select the best, regardless of the origin of its designers. For several years, most companies with a tradition in Italian design, have, also or particularly, been looking abroad to explore creative talent. Likewise, Kristalia believes that with its strong cultural identity, it can and must interact with a variety of foreign designers as part of its business project. For several years, longstanding Italian design companies have been more in tune with foreign designers because the pursuit of a valuable creative contribution is ongoing and without boundaries, but also because the best international designers believe that Italy is still the home of quality production, and they often come here to look for the most interesting examples. Sometimes just like this one, "home-made" at Kristalia.

^{DE} Wenn das „Made in Italy“ die Italiener retten soll, gelingt es dann den Italiener, das „Made in Italy“ zu retten? In den letzten Jahren haben die Verbreitung des „Made in Italy“ in den Medien, die Instrumentalisierung dieses Etiketts und seine gleichzeitige und komplizierte Bürokratisierung teilweise zur Aushöhlung jener oft immateriellen, unantastbaren und wertbezogenen Idee beigetragen, die traditionsgemäß das Bild des „Made in Italy“ in unserer Vorstellung ausmacht. Obwohl es einmal einen Zeitpunkt gab, in dem alle auch ohne lange Erklärungen wussten, was unter „Made in Italy“ zu verstehen ist, ist es heute vielleicht notwendig, dass die Erzeuger einerseits einige Erklärungen mehr liefern, die Verbraucher/Kunden andererseits aber auch mehr Informationen verlangen. Aufgrund einiger rechtsleerer Räume lassen sich nämlich nicht nur gewisse quantitative Parameter umgehen, wodurch auch eine zum Großteil von auswärts stammende Produktion als italienisch bezeichnet werden kann, sondern auch eine tatsächlich in Italien erfolgte Produktion stellt heute nicht mehr automatisch ein Synonym für Qualität dar. Es gibt also 2 Arten von „Made in Italy“ und es ist nicht gesagt, dass alles gerettet werden sollte. Und dann gibt es noch das Konzept des „Made in Italy“ von Kristalia, das dieses Unternehmen seit zwanzig Jahren überzeugend verteidigt.

Kristalia glaubt an den Sinn, die wichtigsten Etappen bei der Entstehung eines Produkts zusammenzufassen und sie seinem Publikum vorzustellen, in der Überzeugung, dass die Verbreitung dieser Geschichte ihren Wert bescheinigt. Diese Geschichte wird so nicht nur zu einer Erzählung im Unternehmen, sondern zu einem erzählerischen Bindeglied der interessantesten italienischen Produktionsrealität, ihrer Besonderheiten sowie der Gründe, weshalb wir wirklich glauben, das sie eines der Beispiele für das „Made in Italy“ ist, das es zu retten gilt. Beginnen wir also mit der Tatsache, dass die Wahl Italiens als Produktionsstätte, aber auch als Beschaffungsort für mehr als 90% der Rohstoffe für Kristalia nicht so sehr auf Lokalismus oder einer „Kirchturmpolitik“ beruht, sondern durch den Umstand begründet wird, dass sich in den meisten Fällen wirklich Italien als einer der bestmöglichen Lieferanten erwiesen hat. Für die restlichen 10% wendet man sich an andere vorzügliche Produktionsländer, wie zum Beispiel Nordeuropa für die Beschaffung der Stoffe, Österreich für die Lamine oder Deutschland für Eisenwaren und Beschläge. Dasselbe gilt für bestimmte Verarbeitungsweisen, bei denen das direkte Umgebungsgebiet des Unternehmens dank der unvergleichlichen Qualität eine Führungsrolle einnimmt. Diese auch strategisch unmittelbare Nähe ist ausschlaggebend, um die im Umkreis von wenigen Kilometern stattfindenden Arbeitsprozesse fortlaufend und direkt zu kontrollieren und die Ergebnisse der angelieferten Halbfertigwaren zu überprüfen. Auf diese Weise verwandelt sich das Produktionsgebiet in einen Dienstleister und das lokale Firmennetz aktiviert erneut ein Austauschsystem, das man nur mehr in ganz bestimmten italienischen Gebieten findet, unter denen Prata zweifellos ein dynamisches Epizentrum darstellt.

Und darüber hinaus: Wenn man an ein heißes Thema dieser Zeit wie jenes der italienischen Fertigung denkt, dann bietet Kristalia ein erstklassiges Beispiel für eine von uns als „hochwertiges industrielles Handwerk“ bezeichnete Produktion, wobei die Idee der Handarbeit mit jener der serienmäßigen Reproduzierbarkeit, das Konzept der hohen Spezialisierung der Arbeiter mit jenem der mechanischen Produktion und die Leistungsfähigkeit mit Slow Production Hand in Hand gehen. Was dann abschließend die Kreativität betrifft, so versucht man erneut, unabhängig von der Herkunft der Designer das Beste auszuwählen. Die meisten traditionellen italienischen Designer-Unternehmen blicken seit etlichen Jahren auch oder vor allem ins Ausland, um kreative Talente ausfindig zu machen. Kristalia ist auf dieselbe Weise davon überzeugt, dass sich das Unternehmen gerade dank seiner starken kulturellen Identität im Bereich des Entwurfs mit Designern austauschen kann und muss, die alle Sprachen sprechen. Bereits seit einiger Zeit scheinen sich die alteingesessenen Unternehmen des italienischen Designs besser mit ausländischen Planern zu verstehen: Dies geschieht, weil die Suche nach einem entscheidenden kreativen Beitrag interessant ist und keine Grenzen kennt, aber auch, weil die besten internationalen Designer glauben, dass Italien immer noch die Heimat der Qualitätsproduktion ist und sie oft genau hier nach den interessantesten Geschichten suchen. Und manchmal ist es genau eine Geschichte wie diese, Home Made by Kristalia.

ES Si es cierto que el made in Italy salvará a los italianos, ¿serán los italianos capaces de salvar el made in Italy? En los últimos años la propagación mediática del made in Italy, la instrumentalización de esta etiqueta y su contemporánea y complicada burocratización han contribuido en parte a vaciar esa sensación a menudo inmaterial, intangible y de alto valor que tradicionalmente ha

dibujado el retrato del made in Italy en nuestro imaginario.

Como si hubiera existido un momento en el que, sin tantas explicaciones, todos entendíamos perfectamente lo que era el made in Italy, mientras que hoy puede ser necesaria alguna especificación más por parte de los productores, que también deberían conocer los clientes o consumidores. A este propósito, existen vacíos jurídicos que permiten evitar algunos parámetros cuantitativos y declarar como italiana una producción que en gran parte llega de fuera. Y, por otro lado, el hecho de producir en Italia ha dejado de constituir de por sí una garantía, sinónimo de calidad. En fin, existe made in Italy y made in Italy y no se puede decir que todo sea aceptable. Luego tenemos la idea de Kristalia sobre el made in Italy, la que defiende de modo convincente desde hace veinte años.

Kristalia cree en el sentido de recapitular las etapas principales del trayecto de un producto y de ofrecerlo a su público convencida de que compartir esta historia certifica su valor. De este modo, esta historia no es un simple relato sobre la empresa, sino una pieza narrativa de la más interesante producción italiana, de sus peculiaridades y de las razones por las que verdaderamente creemos que este es uno de los ejemplos del made in Italy que es posible salvar. Empecemos entonces diciendo que, para Kristalia, la elección de Italia como lugar de producción y como lugar en el que se obtienen más del 90 % de las materias primas no depende de razones relacionadas con localismos o banderas patrióticas, sino del hecho de que Italia sigue siendo considerada como el mejor proveedor posible en la absoluta mayoría de los casos. Para el 10% restante se dirige a otras excelencias, como por ejemplo: al norte de Europa para el abastecimiento de los tejidos, a Austria para los laminados, a Alemania para los materiales de ferretería. Lo mismo vale para algunos tipos de trabajos, en los que el territorio que circunda la empresa ostenta la supremacía de su incomparable calidad. Esta proximidad, incluso estratégicamente, resulta esencial para controlar los procesos de modo constante y directo en un radio de pocos kilómetros, así como para controlar los resultados de los productos semielaborados recibidos. Es así como la localidad se transforma en servicio y como la red local reactiva un intercambio que solo sigue encontrándose en algunos territorios especiales de Italia, de los que Prata representa sin duda un epicentro dinámico. Es más: pensando en un tema candente de estos tiempos, como lo es el de la manufactura italiana, Kristalia ofrece un buen ejemplo de lo que llamamos «alta artesanía industrial» uniendo la idea de la manualidad y la de la reproducibilidad en serie, el concepto de alta especialización de los operadores y el de producción mecánica, la eficiencia y la producción slow.

Por último, con relación a la creatividad se vuelve a buscar una selección de lo mejor, más allá de la procedencia de los diseñadores. Desde hace varios años, la mayor parte de las empresas que cuentan con una tradición en el diseño italiano se dirige también o sobre todo al extranjero para explorar nuevos talentos creativos. Del mismo modo Kristalia cree que, gracias a su fuerte identidad cultural, en el ámbito del proyecto la empresa puede y debe dialogar con diseñadores de todos los idiomas. Desde hace algunos años se observa que empresas históricas del diseño italiano se entienden mejor con los proyectistas extranjeros: esto es así porque la búsqueda de una contribución creativa decisiva e interesante no admite confines, pero también porque los mejores proyectistas internacionales creen que sigue siendo esta la patria de la producción de calidad por excelencia, y a menudo vienen aquí

en busca de las historias más interesantes. A veces como esta, home-made en Kristalia.

ES Si le Made in Italy sauverá los italianos, les italiens seront-ils capables de sauver le Made in Italy ? Durant ces dernières années, la propagation médiatique du Made in Italy, l'instrumentalisation de ce label ainsi que son actuelle bureaucratization plutôt compliquée ont contribué, en partie, à faire disparaître la notion d'immatériel, d'intangible et d'éthique que le mot Made in Italy a traditionnellement tracé dans notre imaginaire. C'est comme si, pendant une période donnée et on ne sait trop pourquoi, tout le monde savait ce que voulait dire Made in Italy alors que, aujourd'hui, il est peut être nécessaire, côté fabricants, de fournir quelques informations supplémentaires à ce sujet et, côté consommateurs/clients, d'en demander davantage.

En effet, non seulement il est possible, à cause de certains vides juridiques, de contourner certains paramètres quantitatifs en déclarant qu'une fabrication est italienne même si celle-ci provient, en grande partie, de l'étranger, mais le fait même de fabriquer en Italie n'est plus une garantie en soi d'être synonyme de qualité. Il y a donc plusieurs types de Made in Italy et ce n'est pas dit que l'on peut tous les sauvegarder.

Et puis, il y a la conception du Made in Italy que Kristalia a adoptée et qu'elle défend de façon convaincante depuis vingt ans. Kristalia est persuadée que le fait de récapituler les étapes principales de la fabrication d'un produit et de partager son histoire avec son public, représente la garantie de sa valeur. C'est ainsi que cette histoire n'est plus une simple histoire d'entreprise, mais le maillon d'un récit intéressant sur la production italienne, sur ses particularités et sur les raisons pour lesquelles nous croyons vraiment qu'il s'agit de l'un des exemples du Made in Italy à sauvegarder. Alors, commençons par dire que si Kristalia a choisi l'Italie comme lieu de fabrication, mais aussi comme lieu pour trouver plus de 90% des matières premières qu'elle utilise, ce n'est pas pour une raison de localismes ou d'histoires de clochers, mais c'est pour le fait que, dans la très grande majorité des cas, elle considère l'Italie comme étant encore le meilleur pays fournisseur possible. Pour les 10% restants, elle s'adresse à d'autres marchés d'excellence comme, par exemple, l'Europe du Nord pour l'approvisionnement de tissus, l'Autriche pour les stratifiés et l'Allemagne pour les matériaux de quincaillerie.

Le même raisonnement est valable pour certains types de réalisations pour lesquels le territoire immédiatement environnant notre entreprise détient une suprématie inégalable au niveau de la qualité. Cette proximité devient essentielle, même au niveau stratégique, pour contrôler les processus de façon constante et directe dans un rayon de quelques kilomètres seulement, ainsi que pour vérifier la qualité des semi-finis à la réception. Voilà comment le district se transforme en service et comment le réseau local rétablit des échanges que l'on ne peut encore trouver que sur certains territoires italiens dont Prata représente, sans aucun doute, un épicerie dynamique.

Et encore: si l'on pense à un thème chaud, en ces temps-ci, comme celui de la manufacture italienne, Kristalia offre un bon exemple de ce que nous appelons «l'artisanat industriel haut de gamme» qui allie le travail manuel et la production en série, le concept de haute spécialisation des ouvriers et celui de fabrication mécanique et, enfin, le rendement et la fabrication à cadence lente.

Quant à la créativité, on essaie, là encore, de choisir le top, quelle que soit la provenance des designers. La plupart des entreprises ayant une tradition dans le design italien observent, depuis plusieurs années, ce qui se passe également, ou surtout, à l'étranger, pour explorer de nouveaux talents créatifs. De son côté, Kristalia, forte de son identité culturelle, est elle aussi convaincue que l'entreprise, dans le cadre des projets, a le pouvoir et le devoir de dialoguer avec des designers de différentes nationalités. Depuis quelques années, il arrive désormais assez fréquemment que d'historiques entreprises de design italien collaborent plus facilement avec des designers étrangers: ceci est dû au fait qu'elles sont constamment à la recherche d'un apport créatif marquant, d'où qu'il vienne, mais aussi au fait que les meilleurs designers internationaux estiment que l'Italie est encore la patrie de la fabrication de qualité et souvent c'est ici qu'ils viennent chercher des histoires intéressantes. Justement comme cette histoire-ci, «home-made» chez Kristalia.

Design session

II Siamo nati nel 1994 da un'idea di alcuni giovani imprenditori che avevano in comune due passioni: il design e il jazz. Eravamo nel posto giusto, al centro di un distretto produttivo che nell'innovazione e nell'eccellenza aveva – e ha tuttora – i suoi punti di forza. Volevamo diventare un esempio di alto artigianato industriale, mostrare come la tecnologia e la creatività potevano accompagnare il made in Italy verso il nuovo millennio. Siamo cresciuti in fretta: in pochi anni siamo diventati un brand riconosciuto a livello internazionale per i suoi progetti innovativi e il segno leggero ed essenziale dei suoi arredi. Oggi, la nostra collezione racconta più di vent'anni di ispirazioni e convinzioni, sintesi del dialogo costante con i nostri designer – una famiglia che inizia a essere numerosa e conta alcuni dei nomi più interessanti del panorama contemporaneo. Progettiamo per il mondo in cui vorremmo vivere: aperto e curioso, coraggioso e creativo, bello e sostenibile. Siamo ancora appassionati di jazz.

EN We were established as a company in 1994 thanks to the idea of some young entrepreneurs who shared two passions: design and jazz. We were in the right place, in the heart of a production district that still has innovation and excellence as its strengths. We wanted to become an example of fine industrial craftsmanship, showing how technology and creativity could accompany "made in Italy" into the new millennium. We quickly expanded: in just a few years, we became a brand that was internationally acknowledged for its innovative projects and the light minimalist design of its furniture. Now, our collection tells the story of more than twenty years of inspiration and belief, the result of constant interaction with our designers – a family that is growing fast and includes some of the most interesting names on the contemporary scene. We design for the world we would like to live in: open and curious, bold and creative, beautiful and sustainable. And we are still passionate about jazz!

DE Wir entstanden 1994 aus der Idee einiger Jungunternehmer, die zwei Leidenschaften gemeinsam hatten: Design und Jazz. Wir waren am richtigen Ort, im Zentrum eines Produktionsgebiets, das Innovation und Vorzüglichkeit bereits damals – und auch noch heute – zu seinen Hauptstärken gemacht hat. Wir wollten ein Beispiel für hochwertiges industrielles Handwerk werden und zeigen, wie Technologie und Kreativität das „Made in Italy“ ins neue Jahrtausend begleiten können. Und wir sind schnell gewachsen: In wenigen Jahren wurden wir zu einer Marke, die aufgrund ihrer innovativen Projekte und der leichten und essenziellen Note ihrer Einrichtungselemente international anerkannt wird. Heute erzählt unsere Kollektion von mehr als zwanzig Jahren voller Inspirationen und Überzeugungen, eine Synthese des ständigen Dialogs mit unseren Designern – eine Familie, die allmählich immer zahlreicher wird und einige der interessantesten Namen der zeitgenössischen Szene umfasst. Wir planen für die Welt, in der wir leben möchten: offen und neugierig, mutig und kreativ, schön und nachhaltig. Und wir sind immer noch leidenschaftliche Jazzanhänger.

ES Hemos nacido en el año 1994 de una idea de algunos jóvenes empresarios que compartían dos pasiones: el diseño y el jazz. Estábamos en el lugar adecuado, en el centro de un distrito industrial que todavía hoy tiene sus puntos de fuerza en la innovación y la excelencia. Queríamos convertirnos en un ejemplo de alta artesanía industrial, mostrar cómo la tecnología y la creatividad podían acompañar al Made in Italy hacia el nuevo milenio. Hemos crecido rápidamente: en pocos años hemos llegado a convertirnos en una marca reconocida a escala internacional por sus innovadores proyectos y por el signo ligero y esencial de sus piezas de mobiliario. Hoy, nuestra colección expresa más de veinte años de inspiración y convicciones, síntesis del diálogo constante con nuestros diseñadores: una familia que empieza a ser numerosa y que cuenta con algunos de los nombres más interesantes del panorama contemporáneo. Diseñamos para el mundo en el que nos gustaría vivir: abierto y curioso, valiente y creativo, bonito y sostenible. Seguimos siendo amantes del jazz.

FR C'est en 1994 que nous avons eu l'idée de créer notre entreprise. Nous étions de jeunes entrepreneurs avec deux passions en commun: le design et le jazz. Nous étions au bon endroit, au cœur d'une zone industrielle où l'innovation et l'excellence étaient – et le sont encore aujourd'hui – les points forts. Nous voulions devenir un exemple de haut artisanat industriel et montrer comment la technologie et la créativité pouvaient accompagner le « Made in Italy » vers le nouveau millénaire. Nous avons grandi très rapidement: en quelques années, nous sommes devenus une marque reconnue au niveau international pour ses projets innovants et le trait léger et épuré de son mobilier. Aujourd'hui, notre collection raconte plus de vingt ans d'inspirations et de convictions, un résumé du dialogue constant avec nos designers – une famille qui commence à être vraiment nombreuse et qui vante plusieurs noms importants dans le secteur contemporain. Nous concevons pour le monde où nous souhaiterions vivre: ouvert et curieux, courageux et créatif, beau et durable. Nous sommes encore passionnés de jazz.



Bebop, Bartoli Design 2001

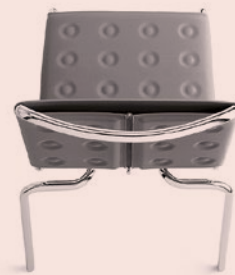

Free, Monica Graffeo 2001



Bird, Bartoli Design 2001

New HQ

Text by Chiara Alessi

^{II} Prima della rivoluzione del 2001, Kristalia è per alcuni anni un'azienda specializzata nella produzione di complementi prevalentemente in vetro. Da qui il suo nome, che deriva dalla fusione delle due parole chiave: cristallo e made in Italy. Ma quel nome è evocatore anche di un'altra specificità, che continua a contraddistinguere Kristalia anche quando la produzione del vetro verrà abbandonata a favore del furniture design: cioè la trasparenza.

La trasparenza infatti è uno dei valori principali di Kristalia e si estende dalla modalità con cui viene affrontato lo sviluppo dei progetti fino ai processi di produzione e di comunicazione, ma investendo infine anche i luoghi dell'azienda che diventano "trasparenti", nel senso di genuini, vivibili, luminosi. Perciò il "posto di lavoro" per Kristalia è determinante, come la luce che lo investe e la natura in cui è immerso. Nonostante il distretto che ospita la sede, Prata, sia il centro pulsante di una fiorente attività produttiva.

In totale controtendenza con il momento storico, proprio nel 2014, Kristalia decide di investire su se stessa, a cominciare dalla sua sede. Non va all'estero, non va neanche a cementificare nei paraggi: invece potenzia, aggiorna e migliora l'esistente, intervenendo sulle aree industriali dismesse e procedendo con una nuova bonifica del terreno e delle strutture che ospita. In controtendenza è anche la scelta di assestare una prassi che storicamente ha illuminato le esperienze di grandi e coraggiose imprese italiane nei territori in cui sono sorte e nei quali hanno cercato di portare i valori della comunità, del suolo, della gente che lì ha abitato, prima ancora che serviti nel ruolo di dipendenti. Le fabbriche-villaggio, le farm si direbbe oggi, il senso sopravvissuto dei distretti nel nostro Paese. È una questione di verdi (alberi, montagne), di bianchi (neve, luce), di neri (buio vs. illuminazione artificiale), di aria pulita, di naturalezza che fa sembrare anche il cemento un colore del paesaggio. È una questione di sostenibilità, che muove dall'idea che un ambiente di lavoro possa assorbire e al contempo produrre l'energia che gli serve, in un circolo virtuoso: così i pannelli fotovoltaici posti sul tetto servono a garantire la sussistenza energetica agli interni che sono progettati nello scambio tra aree votate al lavoro e zone di relax e svago. In questo modo, anche la forza energetica umana promette una risposta combinata tra creatività ed efficienza. La struttura prevede perciò un'area dedicata agli uffici, alla produzione, al carico e scarico merci, ma anche zone ricreative per lo sport e l'intrattenimento, la musica, il cibo, un ampio showroom aperto al pubblico e un'area nella quale si concentreranno le collaborazioni di natura artistica.

Così è nata la nuova azienda, adattata anche nell'aspetto al pensiero che orienta la filosofia di Kristalia e ne guida il catalogo di prodotti: minimalismo, benessere, ordine, serenità, legame con la natura.

^{EN} Before revolutionary changes in 2001, for several years Kristalia was a company specialising in the production of accessories mainly made of glass. Hence its name, which

comes from the fusion of two key words: "cristallo" (crystal glass) and "Italia" (made in Italy). Its name also evokes another special feature, transparency, which continued to make Kristalia stand out even when glass production was abandoned in favour of furniture design. Transparency is one of Kristalia's key values, which can be applied to the way projects are developed, to production processes and advertising, as well as to the company's premises that become "transparent", since they are genuine, liveable and light. For Kristalia, the work environment is crucial, just like the light that illuminates it and nature all around it, despite the fact that the district where Kristalia is based, Prata di Pordenone, is a lively centre of production.

In total contrast with that period, in 2014, Kristalia decided to invest in the company, starting with its headquarters. It did not go abroad or build in the immediate vicinity: instead it strengthened, updated and improved what already existed, recovering land and buildings in disused industrial areas. A further contrast was the company's choice to support a practice that, in the past, highlighted the experiences of leading and courageous Italian companies in the areas where they were established and where they tried to contribute to the values of a community, the land and its people, even before such values were required in employees. Such factory-villages, the so-called "farms" of today, are reminders of the districts in Italy.

It is a question of green (trees and mountains), white (snow and light), black (dark vs. artificial lighting), clean air and naturalness that even allows cement to harmoniously blend in with the landscape.

It is a question of sustainability, arising from the idea that a work environment can absorb and still produce the energy it needs, in a virtuous cycle: so photovoltaic panels are required on the roof to guarantee the energy we need for interiors designed with work areas alternating with relaxation and leisure areas. In this way, human potential also promises a combined result based on creativity and efficiency.

Our premises have an area dedicated to offices and to production, the loading and unloading of goods, as well as a recreational area for sport and entertainment, music, food, a spacious showroom open to the public and an area for hosting partnerships of an artistic nature.

This is how our new company took shape, also adapting its appearance and its catalogue of products according to the concepts of Kristalia's philosophy: minimalism, wellbeing, harmony, tranquillity and a bond with nature.

^{DE} Vor der Revolution im Jahr 2001 war Kristalia für einige Jahre ein ganz auf die Erzeugung von Einrichtungsgegenständen aus Glas spezialisiertes Unternehmen. Daher stammt auch sein Name, der ein Verschmelzen der beiden Schlüsselwörter darstellt: Kristallglas und „Made in Italy“. Aber

dieser Name ist auch Beschwörer einer anderen Besonderheit, die Kristalia auch jetzt noch, nachdem die Glasproduktion zugunsten von Designermöbeln aufgegeben wurde, auszeichnet: die Transparenz.

Transparenz gehört nämlich zu den wichtigsten Werten von Kristalia und reicht von der Art und Weise, mit der die Projektentwicklung in Angriff genommen wird, bis hin zu den Produktions- und Kommunikationsprozessen. Aber auch die Räumlichkeiten des Unternehmens selbst sind davon betroffen und werden so „transparent“, im Sinne von unverfälscht, menschennah und hell. Deshalb ist der „Arbeitsplatz“ für Kristalia so ausschlaggebend wie das Licht, das ihn durchdringt und die Natur, die ihn umgibt. Und das, obwohl das Industriegebiet Prata, in dem der Firmensitz liegt, das pulsierende Zentrum einer überkochenden Produktionstätigkeit ist.

Im klaren Gegenteil zum historischen Moment beschließt Kristalia genau im Jahr 2014, in sich selbst zu investieren und fängt direkt beim Firmensitz an. Das Unternehmen geht nicht ins Ausland und verzichtet auch auf eine Zubetonierung der nahen Umgebung: Stattdessen wird bereits Vorhandenes verstärkt, erneuert und verbessert, indem man durch eine Sanierung des Bodens und der darauf stehenden Bauten in aufgelassene Industrieanlagen investiert. Gegenläufig ist auch die Entscheidung, eine Praxis zu unterstützen, die historisch gesehen die Erfahrungen der großen und mutigen italienischen Unternehmen in ihren Entstehungsgebieten erhellt haben. Sie haben versucht, die Werte der Gemeinschaft, des Bodens, der Menschen in ihre Unternehmen einzuschließen, noch bevor diese überhaupt eine Mitarbeiterrolle übernehmen. Die Fabriksiedlungen, die man heute als „Farmen“ bezeichnen würde, sind die hiesigen Produktionsgebiete.

Es ist eine Frage der Farbe Grün (Bäume, Berge), der Farbe Weiß (Schnee, Licht), der Farbe Schwarz (Dunkelheit gegen künstliche Beleuchtung), der reinen Luft und der Natürlichkeit, die auch den Zement zu einer Farbe der Landschaft macht. Es ist eine Frage der Umweltverträglichkeit, die aus der Idee entsteht, dass ein Arbeitsbereich die von ihm benötigte Energie durch einen meisterhaften Kreislauf aufnehmen und gleichzeitig wieder erzeugen kann: Die auf dem Dach installierten Fotovoltaik-Paneele dienen daher als Garantie für die Energieversorgung der Innenräume, die einen ständigen Wechsel aus Arbeitszonen und Erholungs- und Unterhaltungsbereichen bieten. Auf diese Weise verspricht auch die Kraft der menschlichen Energie eine aus Kreativität und Effizienz gebildete Antwort.

Der Bau sieht also jeweils einen Bereich für die Büroräume, für die Produktion und für das Ein- und Ausladen der Waren vor, er besitzt aber auch Zonen für Sport und Unterhaltung, für Musik, für das leibliche Wohl, einen großen, öffentlich zugänglichen Showroom und einen Bereich, der für die Zusammenarbeiten künstlerischer Natur reserviert ist. Es entstand so das neue Unternehmen, das auch vom Aussehen her dem Grundgedanken der Philosophie von Kristalia und dem daraus abgeleiteten Produktkatalog entspricht: Minimalismus, Wohlbefinden, Ordnung, Heiterkeit, Bündnis mit der Natur.

^{ES} Antes de la revolución del año 2001, Kristalia ha sido durante años una empresa especializada en la producción de complementos, principalmente de cristal. Debe a esto su nombre, que deriva de la fusión de dos palabras clave: cristal y made in Italy. Pero este nombre también evoca otra particularidad que ha seguido distinguiendo a Kristalia incluso después de abandonar la producción del cristal para dedicarse al diseño de mobiliario: la transparencia.

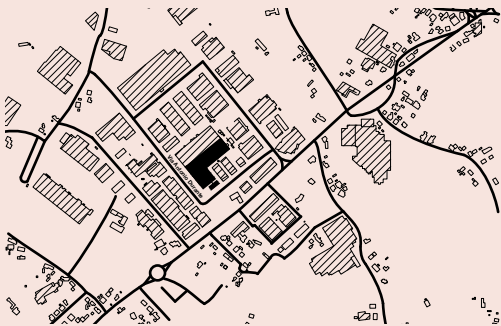

En efecto, la transparencia es uno de los valores principales de Kristalia, presente tanto en su modo de afrontar el desarrollo de los proyectos como en sus procesos de producción y comunicación o en los lugares de la empresa, que se vuelven «transparentes»: genuinos, vivibles y luminosos. Por este motivo, para Kristalia el «lugar de trabajo» es determinante, como la luz que lo atraviesa y la naturaleza que lo rodea. A pesar de ello, la localidad que aloja su sede, Prata, es el centro palpante de una frenética actividad productiva.

En total contrarrendencia con nuestro momento histórico, en el año 2014 Kristalia decide invertir en sí misma, empezando por su sede. No se marcha al extranjero, no cubre de cemento sus alrededores: en lugar de ello potencia, actualiza y mejora la realidad existente interviniendo en las áreas industriales abandonadas y llevando a cabo una nueva rehabilitación del terreno y de las estructuras que aloja. Siempre en contrarrendencia, elige seguir una praxis que ha iluminado históricamente las experiencias de grandes y valerosas empresas italianas en los territorios que las han visto nacer, donde han intentado infundir los valores de la comunidad, del suelo y de la gente que los ha habitado antes de que fueran acogidos como empleados. Las fábricas-poblado, las farm como las llamaríamos hoy, un valor que ha sobrevivido en las localidades de nuestro país.

Es una cuestión de verdes (árboles, montañas), de blancos (nieve, luz), de negro (oscuridad versus iluminación artificial), de aire limpio y de naturaleza, que hace que incluso el cemento parezca un color del paisaje. Es una cuestión de sostenibilidad, que viene de la idea de que un ambiente de trabajo puede absorber y al mismo tiempo producir la energía que necesita, en un círculo virtuoso: partiendo de este principio, los paneles fotovoltaicos situados en el techo sirven para garantizar la subsistencia energética de los ambientes interiores, proyectados creando un intercambio entre áreas destinadas al trabajo y zonas de ocio y relax. De este modo, hasta la fuerza energética humana promete una respuesta que combina creatividad y eficiencia.

La estructura incluye un área dedicada a las oficinas, a la producción y a la carga y descarga de mercancías, pero también zonas recreativas para el deporte y el entretenimiento, la música y la comida, una amplia sala de exposiciones abierta al público y un área donde se concentrarán las colaboraciones de tipo artístico. Así ha nacido la nueva empresa, adaptando también su aspecto al pensamiento que orienta la filosofía de Kristalia y que guía su catálogo de productos: minimalismo, bienestar, orden, serenidad y vínculo con la naturaleza.

Avant le tournant de 2001, Kristalia a été, pendant quelques années une entreprise spécialisée dans la production de compléments réalisés, pour la plupart, en verre. C'est d'ailleurs de là que vient son nom qui est formé de la fusion de deux mots clés: «cristallo» (NDT. verre en italien) et Made in Italy. Par ailleurs, ce nom évoque également une autre caractéristique qui continue à démarquer Kristalia même lorsqu'elle



Asbestos removal



Demolition of old premises



Green area



5



1

abandonne la production du verre en faveur du design de meubles: à savoir la transparence. En effet, la transparence est l'une des valeurs principales que Kristalia adopte aussi bien pour les modalités utilisées pour développer les projets que dans les processus de fabrication et de communication, et que l'on retrouve également dans les locaux de l'entreprise qui deviennent, eux aussi, «transparents» c'est-à-dire naturels, agréables à vivre et lumineux. Tout cela en dépit du fait que la ville de Prata où son siège est implanté, représente le cœur névralgique d'un secteur de production très dynamique.

C'est en allant à contre-courant de la tendance de l'époque que Kristalia décide, exactement en 2014, d'investir sur elle-même, en commençant par son siège. Elle ne s'implante pas à l'étranger et n'envisage pas non plus de fabriquer de nouveaux bâtiments dans les alentours: elle décide plutôt de renforcer, d'actualiser et d'améliorer ce qui existe déjà, en intervenant sur les aires industrielles abandonnées et en requalifiant le terrain et les structures où elle est implantée. C'est toujours en allant à contre-courant qu'elle choisit de soutenir une formule qui a mis en relief les expériences de plusieurs grandes et courageuses entreprises italiennes qui ont essayé d'apporter, dans les lieux où elles sont nées, les valeurs de la communauté, du territoire et des gens qui y ont

habité, bien avant d'en devenir les salariés. Les villages-ouvriers - on dirait aujourd'hui les «farms», le sens des districts de notre pays, qui a survécu.

C'est une question de verts (arbres, montagnes), de blancs (neige, lumière), de noir (la nuit contre l'éclairage artificiel), d'air pur, de naturel, qui fait ressembler même le béton à une couleur du paysage.

C'est une question de durabilité engendrée par l'idée qu'un lieu de travail peut à la fois consommer et produire l'énergie dont il a besoin, dans un cercle vertueux: c'est ainsi que les panneaux photovoltaïques installés sur le toit servent à garantir les besoins énergétiques des locaux conçus pour favoriser les échanges entre les zones vouées au travail et celles destinées à la détente et à la distraction. De cette façon, la force énergétique de l'homme apporte elle aussi une réponse alliant créativité et efficacité.

La structure prévoit donc une zone réservée aux bureaux, à la production, au chargement et au déchargement de la marchandise, mais également des zones de détente dédiées au sport, à la convivialité, à la musique, à la nourriture, un vaste show-room ouvert au public et enfin une zone spécialement réservée aux collaborations de nature artistique.

C'est ainsi qu'à vu le jour cette nouvelle entreprise dont l'aspect est lui aussi adapté à la pensée qui anime la philosophie de Kristalia et qui lui sert de guide au niveau du catalogue des produits, à savoir: minimalisme, bien-être, ordre, sérénité, lien avec la nature.

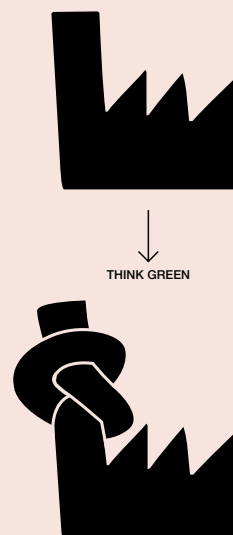
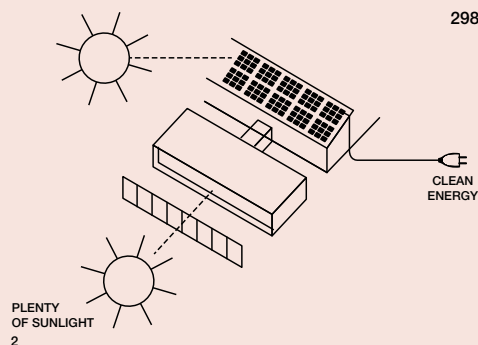

3



4



5

The Club

clubkristalia.it

IT Raccontiamo sempre che nel nostro DNA ci sono il design e il jazz. Perciò, quando nel 2015 ci siamo trasferiti nella nuova sede, abbiamo pensato che non poteva mancare uno spazio dove ospitare concerti: è nato così il Club Kristalia. L'abbiamo progettato perché fosse bello, accogliente e non convenzionale. Uno spazio industriale in una zona industriale che per una sera al mese ospita chiunque abbia voglia di ascoltare della buona musica, vedere un film o un documentario, assistere alla presentazione di un libro, visitare una mostra d'arte o design in una sala realizzata in collaborazione con marchi importanti del mondo del sound design, eccellente per la diffusione musicale e visiva. Il progetto è curato internamente, dalla direzione artistica all'organizzazione: è il nostro modo di dire grazie alla comunità e al territorio che ci hanno permesso di crescere.

EN **We always say that design and jazz are part of our DNA. So, when we moved to our new headquarters in 2015, we knew we just had to have a space for hosting concerts: this led to the creation of Club Kristalia. We designed it to be attractive, welcoming and unconventional. On one evening a month, this industrial space in an industrial district is open to anyone who wants to listen to good music, watch a film or a documentary, attend a book presentation, or visit an art or design exhibition in a room created in collaboration with leading brands in the sound design world, which is excellent for musical and visual diffusion. The project is internally managed, from its artistic direction to its organisation: it is our way of saying thanks to the local community and territory that have allowed us to grow.**

DE Wir erzählen immer, dass Design und Jazz Bestandteile unserer DNA sind. Als wir daher im Jahr 2015 in den neuen Firmensitz übersiedelt sind, haben wir gedacht, dass auf keinem Fall ein Platz für die Veranstaltung von Konzerten fehlen darf: Es entstand so der Club Kristalia. Bei der Planung haben wir vor allem darauf geachtet, dass er schön, einladend und unkonventionell ist. Ein Industriegebiet in einem Industriegebiet, der an einem Abend im Monat jedem offensteht, der gute Musik hören, einen Film oder eine Dokumentation sehen, an der Präsentation eines Buches teilnehmen oder eine Kunst- oder Designausstellung besuchen möchte. Und das alles in einem Raum, der in Zusammenarbeit mit führenden Marken der Welt des Sound Designs entstanden ist, die für ihre erstklassische musikalische und visuelle Verbreitung bekannt sind. Das Projekt wird von der künstlerischen Leitung bis zur Organisation intern betreut: Es ist unser ganz spezieller Dank an die Gemeinschaft und an das Gebiet, die unser Wachstum erst möglich gemacht haben.

ES Siempre decimos que en nuestro ADN están presentes el diseño y el jazz. Por eso, cuando en el año 2015 nos trasladamos a la nueva sede pensamos que no podía faltar un espacio para

organizar conciertos: fue así como nació el Club Kristalia. Lo habíamos proyectado de forma que resultase bonito, acogedor y poco convencional. Un espacio industrial en una zona industrial que, una noche al mes, reúne a todas las personas que desean escuchar buena música, ver una película o un documental, asistir a la presentación de un libro o visitar una muestra de arte o de diseño en una sala realizada en colaboración con importantes marcas del mundo del sound design, excelente para la difusión musical y visual. El proyecto es gestionado internamente, de la dirección artística a la organización: es el modo de manifestar nuestro agradecimiento a la comunidad y al territorio que nos ha permitido crecer.

FR Nous racontons toujours que, dans notre ADN, nous avons le design et le jazz. Voilà pourquoi, en 2015, lorsque nous nous sommes transférés dans notre nouvelle usine, nous avons pensé qu'il ne pouvait pas manquer un espace pour organiser des concerts: c'est ainsi qu'est né le Club Kristalia. Nous l'avons conçu de façon à ce qu'il soit beau, accueillant et non conventionnel. Un espace industriel dans une zone industrielle qui reçoit, un soir par mois, quiconque a envie d'écouter de la bonne musique, de voir un film ou un documentaire, d'assister à la présentation d'un livre, de visiter une exposition d'art ou de design dans une salle réalisée en collaboration avec des marques importantes dans le secteur du Sound Design, excellente pour la diffusion de la musique et de films. Le projet a été réalisé internement, de la direction artistique jusqu'à l'organisation: c'est notre façon de remercier la communauté et le territoire qui nous ont permis de croître.



Alfred "Pee Wee" Ellis



Mark de Clive-Lowe



1

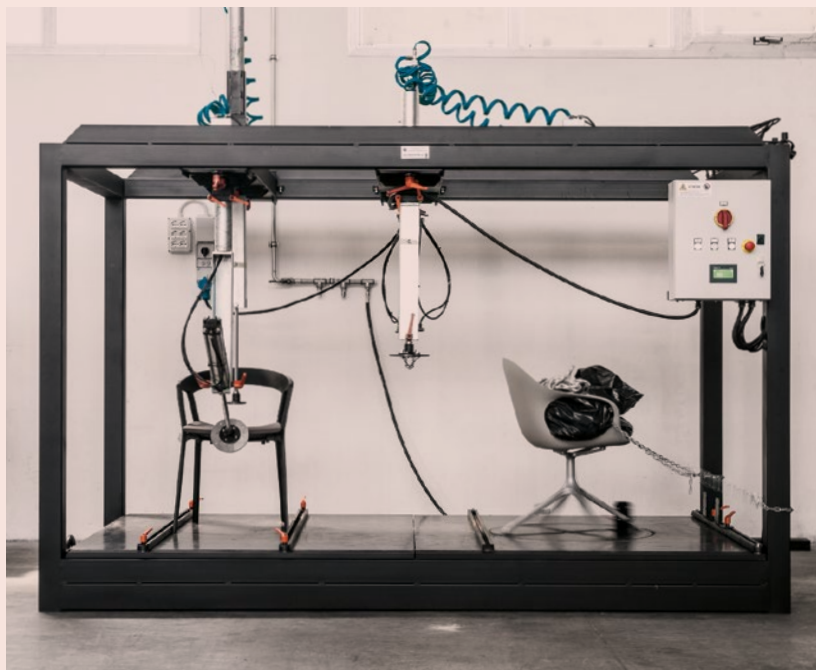
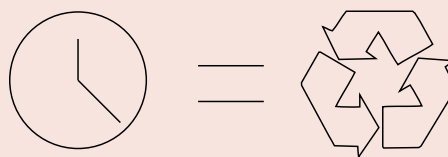

"Ercole" test machine



Cardboard box machine



New eco-friendly packaging

Durability = Eco – friendliness

■ Pensiamo che qualità e sostenibilità siano due modi complementari di parlare di futuro: per questo lavoriamo per allungare la vita dei nostri prodotti e per ridurre l'impatto ambientale di tutte le nostre attività – contemporaneamente. I nostri arredi durano nel tempo, resistendo alle sollecitazioni estreme e a quelle di ogni giorno. Vogliamo che chi acquista una sedia, un tavolo o un complemento Kristalia possa goderne per tutta la vita, così come le generazioni che verranno. In prospettiva significa consumare meno risorse, ma anche avere il privilegio di poter raccontare una storia attraverso un oggetto. Preferiamo materiali che si possono riciclare, anche più volte, come il vetro, l'acciaio, il polipropilene e l'alluminio. Seguiamo standard molto severi anche nella selezione dei materiali e dei semilavorati, sempre realizzati da aziende italiane che seguono i nostri stessi criteri di qualità ed ecologia. In controtendenza, stiamo portando internamente una serie di lavorazioni che in passato erano svolte all'esterno, come quella dei profilati e la verniciatura a polvere dei metalli: questo ci consente di abbassare il nostro impatto ambientale, azzerando le emissioni legate ai trasporti e controllando l'impronta delle nostre attività, alimentate per il 50% dal nostro impianto fotovoltaico. Abbiamo abbandonato plastiche e polistirolo a favore degli imballaggi in cartone 100% riciclabile, realizzati da un nuovo macchinario posto alla fine della linea produttiva. Tutti i nostri prodotti sono testati internamente da Ercole, una macchina che esegue molti più test e cicli di quelli richiesti a livello italiano e internazionale, e sono collaudati da enti esterni, che ne certificano la resistenza meccanica, la reazione al fuoco, la sicurezza e la salubrità, sempre con ottimi risultati.

■ **We believe that quality and sustainability are two complementary ways of talking about the future: so we work to extend the life of our products while reducing the environmental impact of all our activities. Our furniture is long-lasting, resisting extreme and everyday stress. We want those who buy a chair, a table or a furnishing accessory from Kristalia to be able to enjoy them for the rest of their life, and the same goes for future generations. In perspective, it means using fewer resources and having the privilege of being able to tell a story through an object. We prefer materials that can be recycled several times, such as glass, steel, polypropylene and aluminium. We also follow very strict standards when selecting materials and semi-finished products, which are always made by Italian companies that respect our criteria of quality and ecology. In contrast to current trends, we are bringing a series of processes that were previously outsourced back into the company, including profiling and powder-coating of metals: this allows us to lower our environmental impact, eliminating emissions related to transport and controlling the carbon footprint of our activities, for which our photovoltaic system provides 50% of the power required. We have eliminated plastics and polystyrene and now prefer to use 100% recyclable cardboard packaging, made by a new machine positioned at the end of the**

production line. All our products are internally tested by Ercole, a machine that performs many more tests and cycles than those required by Italian and international standards. They are tested by external bodies, which certify their mechanical resistance, reaction to fire, safety and health, and always produce excellent results.

■ Wir sind der Ansicht, dass Qualität und Nachhaltigkeit zwei komplementäre Wege sind, um über die Zukunft zu sprechen: Aus diesem Grund arbeiten wir daran, die Lebensdauer unserer Produkte zu verlängern und die Umweltbelastung aller unserer Aktivitäten zu reduzieren – und das gleichzeitig. Unsere Möbel sind langlebig und halten den extremsten Belastungen und jenen des ganz normalen Alltags stand. Wir möchten, dass diejenigen, die einen Stuhl, einen Tisch oder ein Zusatzelement von Kristalia kaufen, das Produkt ein Leben lang genießen können, und dass auch die nachfolgenden Generationen Freude daran haben. In Perspektive bedeutet das, weniger Ressourcen zu verbrauchen, aber auch das Privileg zu besitzen, über ein Objekt eine Geschichte erzählen zu können. Wir bevorzugen Materialien, die mehrfach wiederverwertbar sind, wie Glas, Stahl, Polypropylen und Aluminium. Auch bei der Auswahl der Materialien und der Halbfertigwaren, die immer von italienischen Unternehmen hergestellt werden, die unsere gleichen Qualitäts- und Umweltkriterien erfüllen, halten wir uns an sehr strenge Standards. Im Gegensatz dazu bringen wir intern eine Reihe von Bearbeitungsprozessen ein, die in der Vergangenheit extern durchgeführt wurden, wie z.B. die Erzeugung von Profilen und die Pulverbeschichtung von Metallen: Das ermöglicht es uns, unsere Auswirkung auf die Umwelt zu senken, Emissionen im Zusammenhang mit dem Transport auf Null zu reduzieren und den Einfluss unserer Arbeiten zu kontrollieren, die hinsichtlich Energie zu 50% von unserer Photovoltaikanlage versorgt werden. Wir haben auf Kunststoffe und Polystyrol zugunsten von 100% recycelbaren Kartonagen verzichtet, die mit einer neuen Maschine am Ende der Produktionslinie hergestellt werden. Alle unsere Produkte werden intern von Ercole getestet, eine Prüfmaschine, die viel mehr Tests und Zyklen durchführt, als auf italienischer und internationaler Ebene erforderlich sind. Außerdem werden die Produkte von externen Stellen geprüft, die die mechanische Beständigkeit, das Brandverhalten, die Sicherheit und die Ungefährlichkeit für die Gesundheit bescheinigen, wobei immer hervorragende Ergebnisse erzielt werden.

■ Pensamos que calidad y sostenibilidad son dos modos complementarios de hablar del futuro: por eso trabajamos para prolongar la vida de nuestros productos y para reducir el impacto medioambiental de todas nuestras actividades, simultáneamente. Nuestros muebles duran en el tiempo, resistiendo a las situaciones extremas y cotidianas. Queremos que quien compra una silla, una mesa o un complemento Kristalia pueda disfrutar de él durante toda su vida, al igual que las generaciones futuras. En perspectiva, esto significa consumir menos recursos, pero también tener el

privilegio de poder contar una historia a través de un objeto. Preferimos los materiales que pueden ser reciclados, incluso varias veces, como el cristal, el acero, el polipropileno y el aluminio. También seguimos estándares muy estrictos en la selección de los materiales y de los productos semielaborados, realizados siempre por empresas italianas que adoptan nuestros mismos criterios de calidad y ecología. En controtendencia, nos estamos ocupando internamente de una serie de trabajos que antes se realizaban fuera de la empresa, como el de los perfiles o el barnizado con polvo de los metales: esto nos permite reducir nuestro impacto medioambiental, eliminando las emisiones producidas en el transporte y controlando el efecto de nuestras actividades, alimentadas al 50% por nuestra planta fotovoltaica. Hemos abandonado el plástico y el poliestireno en favor de los embalajes de cartón 100% reciclable, realizados por una nueva maquinaria ubicada al final de la línea productiva. Todos nuestros productos son probados internamente por Ercole, una máquina que efectúa muchas más pruebas de las requeridas a nivel italiano e internacional, y son ensayados por entidades externas que certifican su resistencia mecánica, reacción al fuego, seguridad y salubridad, siempre con excelentes resultados.

■ Nous pensons que la qualité et la durabilité sont deux modes complémentaires de parler de l'avenir: voilà pourquoi nous travaillons pour prolonger la vie de nos produits et pour réduire l'impact sur l'environnement de toutes nos activités – et cela en même temps. Nos meubles durent longtemps, résistent aux sollicitations extrêmes et à celles de tous les jours. Nous voulons que celles ou ceux qui achètent une chaise, une table ou un complément Kristalia puissent en profiter toute leur vie durant, tout comme les générations futures. En vue de l'avenir, cela signifie consommer moins de ressources, mais également avoir le privilège de pouvoir raconter une histoire à travers un objet. Nous préférons des matériaux que l'on peut recycler, même plusieurs fois, comme le verre, l'acier, le polypropylène et l'aluminium. Nous suivons des normes très sévères, même dans la sélection des matériaux et des produits semi-finis, rigoureusement réalisés par des entreprises italiennes qui suivent nos mêmes critères de qualité et d'écologie. Conscients d'aller à contre tendance, nous sommes en train d'effectuer une série d'usinages que, dans le passé, nous donnions en sous-traitance, comme celles des profilés et du laquage à la poudre des métaux: ce choix nous permet de réduire notre impact sur l'environnement, en annulant les émissions liées aux transports et en contrôlant l'empreinte de nos activités alimentées, à 50%, par notre installation photovoltaïque. Nous avons abandonné le plastique et le polystyrène en faveur des emballages en carton 100% recyclable, réalisés par une nouvelle machine située à la fin de la ligne de production. Tous nos produits sont testés dans notre usine par Ercole – une machine qui effectue beaucoup plus d'essais et de cycles que ceux requis au niveau italien et international – et sont contrôlés par des organismes extérieurs qui en certifient la résistance mécanique, la réaction au feu, la sécurité et la salubrité, toujours avec d'excellents résultats.



New aluminium processing department

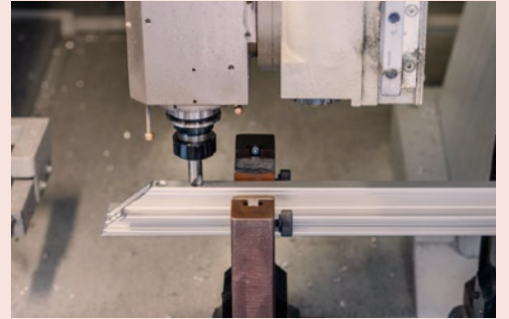

2

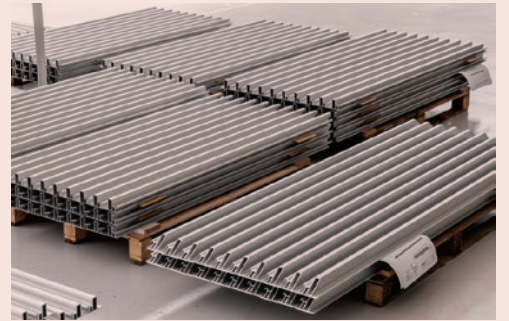

3



4



Table leg assembly area



6



New powder-coating department



2



3



Handmade finishes



Bartoli Design (I)



Luciano Bertoncini (I)



Bluezone (I)



Claesson Koivisto Rune (S)



Monica Graffeo (I)

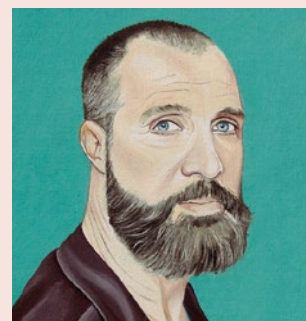

Harry-Paul (NL)

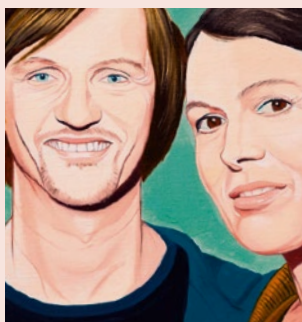

Läufer & Keichel (D)



LucidiPevere (I)

Family designers



Angelo Natuzzi (I)



Neuland (D)



Luca Nichetto (I)



Patrick Norguet (F)



Kensaku Oshiro (J)



Christophe Pillet (F)



Ramos Bassols (E)



Salvatore+Marie (I)

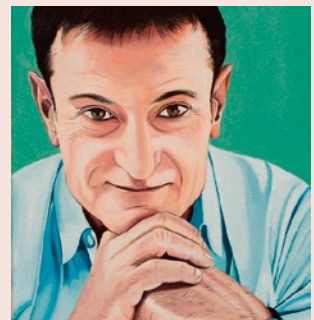

Paolo Zani (I)



1



2



3



4



5



7



Production process

Honourable mention

adi-design.org

Il tavolo Boiaccia, ideato da Paolo Lucidi e Luca Pevere e sviluppato insieme a Kristalia, è stato premiato con la menzione d'onore del Compasso d'Oro ADI 2014. Un riconoscimento fra i più prestigiosi nel mondo del design, per uno dei prodotti più originali non solo della collezione Kristalia, ma anche nel panorama internazionale dell'arredamento. Il cemento, un materiale grezzo ed imperfetto e proprio per questo ricco di sensazioni alla vista ed al tatto, è l'inusuale materia prima di un tavolo sorprendentemente raffinato e poetico. Un'opera, fra industria e artigianato, che riesce ad ammaestrare questa sostanza fluida colandola in uno stampo come se si trattasse di metallo o di plastica. Le lievi variazioni superficiali e cromatiche, causate dai diversi gradi di temperatura ed umidità dell'aria durante l'asciugatura del cemento, rendono ogni tavolo ancora più unico. Per tutte queste caratteristiche, Boiaccia ha ricevuto la menzione d'onore insieme ad altri progetti altrettanto originali, innovativi e significativi, da parte della Giuria composta da Anders Byriel, Vivian Cheng, Giorgio De Ferrari, Stefan Diez, Defne Koz, Mario Gagnon, Paolo Lomazzi, Laura Traldi, nel corso di una cerimonia tenutasi il 28 maggio 2014 a Milano, nelle officine Ex-Ansaldo in quartiere Tortona, famoso per gli eventi del FuoriSalone.

EN The Boiaccia table, designed by Paolo Lucidi and Luca Pevere and developed together with Kristalia, received an honourable mention at the ADI Compasso d'Oro Awards 2014. It is one of the most prestigious awards in the design sector, for one of the most original products, not only in the Kristalia collection but also on the international furniture scene. Cement, a rough and imperfect material that offers a range of visual and tactile sensations, is an unusual raw material for such a surprisingly refined and poetic table. A technique, which is both industrial and artisan, allows this fluid substance to be cast in a mould as if it were metal or plastic. The slight variations in its surface and colour, due to different degrees of temperature and humidity in the air during the drying phase of the cement, make each table even more unique. Thanks to all these features, Boiaccia received an honourable mention along with other just as original, innovative and important design projects, from the panel of judges comprising Anders Byriel, Vivian Cheng, Giorgio De Ferrari, Stefan Diez, Defne Koz, Mario Gagnon, Paolo Lomazzi and Laura Traldi. The award ceremony was held on 28 May 2014 in Milan, in the former Ansaldo workshops in the Tortona district, well-known for its FuoriSalone events.

Der von Paolo Lucidi und Luca Pevere kreiert und gemeinsam mit Kristalia entwickelte Tisch Boiaccia wurde bei der Preisverleihung des Compasso d'Oro ADI 2014 mit einer ehrenvollen Erwähnung prämiert. Eine der prestigevollsten Auszeichnungen der Welt des Designs für ein Produkt, das nicht nur in der Kollektion Kristalia, sondern auch im internationalen Einrichtungsportfolio zu den originellsten Entwürfen zählt. Der Zement, ein rohes und unperfektes Material, das gerade deshalb reich an sicht- und fühlbaren Wahrnehmungen ist,

präsentiert sich als ungewohnter Werkstoff dieses überraschend raffinierten und poetischen Tischmodells. Ein aus Industrie und Handwerk erschaffenes Werkstück, dem es gelingt, diese flüssige Substanz zu bändigen und wie Metall oder Kunststoff in eine Form zu gießen. Die leichten Unterschiede bei Oberfläche und Farbton, die durch verschiedene Temperaturen und die während des Trocknens des Zements herrschende Luftfeuchtigkeit entstehen, machen jeden Tisch noch einzigartiger. Für alle diese Merkmale wurde Boiaccia gemeinsam mit anderen, gleichermaßen originellen, innovativen und aussagekräftigen Projekten vonseiten der aus Anders Byriel, Vivian Cheng, Giorgio De Ferrari, Stefan Diez, Defne Koz, Mario Gagnon, Paolo Lomazzi und Laura Traldi bestehenden Jury eine ehrenvolle Erwähnung zuerkannt. Die feierliche Zeremonie fand am 28. Mai 2014 in Mailand statt, und zwar in den Räumlichkeiten des Ex Ansaldo im Stadtteil Tortona, das für seine Events des FuoriSalone berühmt ist.

La mesa Boiaccia, ideada por Paolo Lucidi y Luca Pevere y desarrollada junto a Kristalia, ha sido premiada con la mención de honor del Compás de Oro ADI 2014. Uno de los reconocimientos más prestigiosos en el mundo del diseño para uno de los productos más originales, no solo de la colección Kristalia, sino de todo el panorama internacional del sector del mueble. Bruto e imperfecto, y precisamente por eso capaz de suscitar múltiples sensaciones a nivel táctil y visual, el cemento es la inusual materia prima de una mesa sorprendentemente poética y elegante. Una obra que se sitúa entre la industria y la artesanía y que logra amañar esta sustancia fluida colándola en un molde como si se tratase de plástico o de metal. Sus leves variaciones superficiales y cromáticas, causadas por los distintos grados de temperatura y humedad del aire durante el secado del cemento, hacen que cada mesa resulte absolutamente

única. Gracias a estas características, Boiaccia ha recibido junto a otros proyectos igualmente originales, innovadores y significativos la mención de honor del jurado compuesto por Anders Byriel, Vivian Cheng, Giorgio De Ferrari, Stefan Diez, Defne Koz, Mario Gagnon, Paolo Lomazzi y Laura Traldi durante la ceremonia que tuvo lugar el 28 de mayo de 2014 en Milán, en las oficinas Ex-Ansaldo del barrio Tortona, famoso por los eventos del FuoriSalone.

La table Boiaccia, conçue par Paolo Lucidi et Luca Pevere et réalisée en collaboration avec Kristalia, a reçu la mention d'honneur au concours "Compasso d'Oro ADI 2014". Il s'agit de l'une des récompenses parmi les plus prestigieuses dans le domaine du design, attribuée à l'un des articles les plus originaux, non seulement de la collection Kristalia, mais également au niveau de la décoration internationale. Le béton est un matériau brut, présentant des imperfections. Mais c'est justement pour cela qu'il procure de fortes sensations au regard et au toucher: c'est une matière première inédite pour une table étonnante, raffinée et poétique. Une réalisation, fruit de l'alliance industrie-artisanat, réussissant à maîtriser cette substance fluide en la coulant dans un moule comme s'il s'agissait de métal ou de plastique. Les légères variations superficielles et chromatiques, causées lors du séchage du béton par les différences de température et d'humidité de l'air, rendent cette table encore plus unique en son genre. Ce sont toutes ces caractéristiques qui ont fait que Boiaccia a reçu la mention d'honneur, tout comme d'autres projets tout aussi originaux, innovateurs et remarquables, de la part d'un jury composé de Anders Byriel, Vivian Cheng, Giorgio De Ferrari, Stefan Diez, Defne Koz, Mario Gagnon, Paolo Lomazzi et Laura Traldi, au cours d'une cérémonie qui s'est déroulée le 28 mai 2014 à Milan, auprès des usines Ex-Ansaldo dans le quartier Tortona qui est célèbre pour ses événements OFF.



Paolo Lucidi and Luca Pevere



Metal

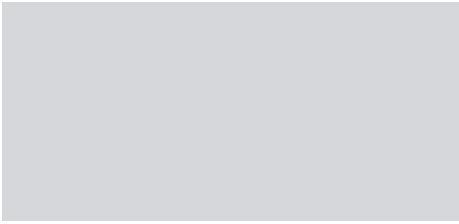

Anodised aluminium



Polished aluminium



Polished chrome steel

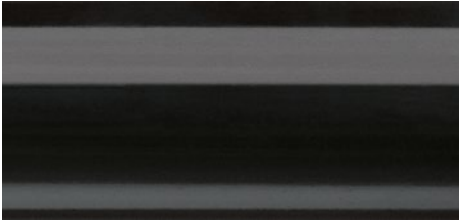

Black chrome steel



Satin-finish chrome steel



Brass



Brass finish steel

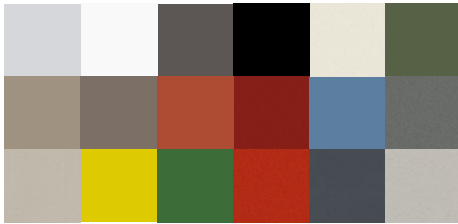

Polyester powder-coated metal

Wood



European oak



Walnut stained oak



Wengé stained oak



Black oak



Ebony

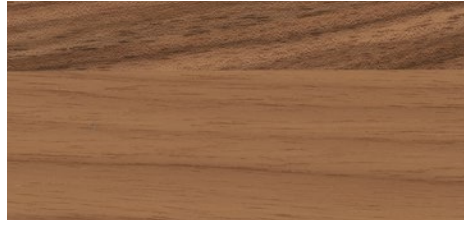

Walnut



Beech



Cork

Alucompact® laminate
4 colours



White

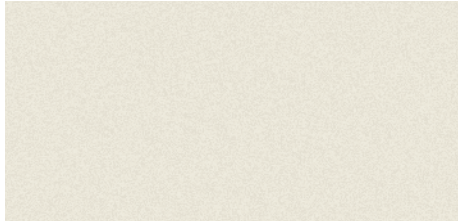

Sand grey



Anthracite grey



Black

Pure-white laminate



White

HPL laminate
2 colours



White

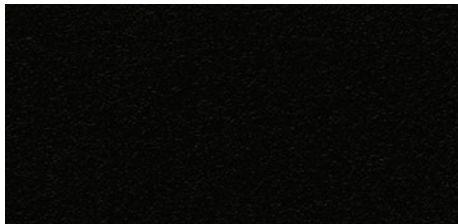

Black

Fenix-NTM®

5 colours

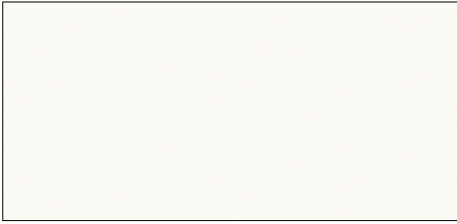

Kos white 0032



Ottawa beaver 0717



London grey 0718



Bromo grey 0724



Ingo black 0720

Low light reflectivity, extremely matt surface

Easy to clean

Anti-fingerprint

Soft touch

Suitable for contact with food

Antistatic

Enhanced anti-bacterial properties

Resistance to scratches and abrasion

Resistance to dry heat

Hygienic

High resistance to acid solvents and household reagents

Mold-resistant

Rub resistance

Hydro-repellent

Resistance to impact

Lightfastness

Tempered glass
6 colours



Extra white back-painted (gloss or matt)



Titanium back-painted (gloss or matt)



Anthracite grey back-painted (gloss or matt)



Black back-painted (gloss or matt)



Transparent extra light



Transparent smoked

DEKTON® by Cosentino
3 colours



Zenith white

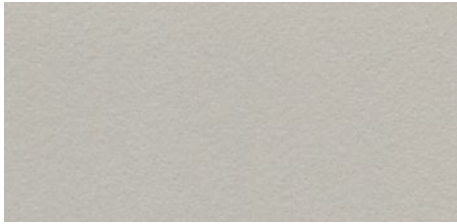

Ventus grey



Aura (digital marble)



Highly UV resistant



Resistant to abrasion



Resistant to stain



Maximum resistance to fire and heat



Low water absorption



High mechanical resistance



Colour stability



Fireproof material

Stone
2 colours



Atajia Cream Limestone

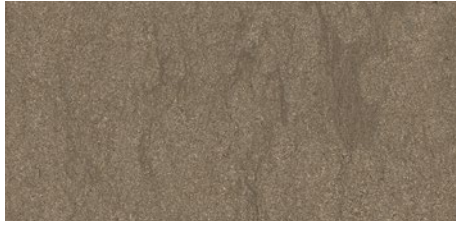

Pietra di Fossena

Cement
2 colours



Light grey



Dark grey

Cristalplant® solid surface

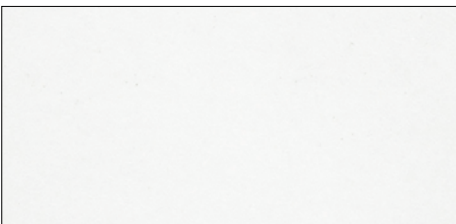

White

Polypropylene

8 colours

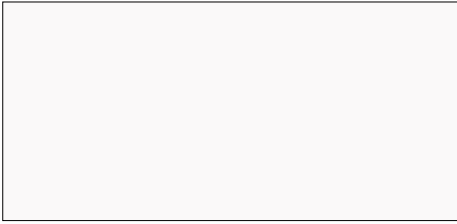

PP01 White



PP03 Black



PP05 Beige



PP07 Red coral

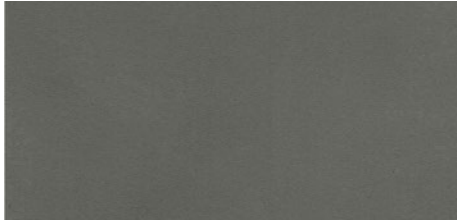

PP10 Grey basalt



PP11 Light grey

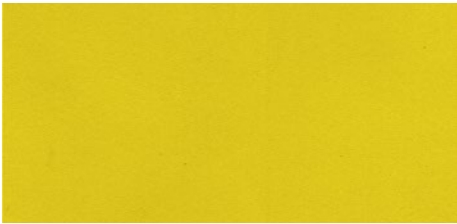

PP12 Zinc yellow

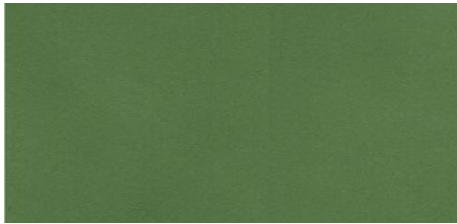

PP13 Meadow green

	PP01	PP03	PP05	PP07	PP10	PP11	PP12	PP13
BCN	●	●	●	●	○	●	●	●
Colander	●	●	●	●	●	●	●	●
Compas	●	●	●	○	○	●	○	○
Degree	●	●	○	○	○	○	○	○
LP	●	●	●	●	●	○	○	○
Mem	●	●	●	○	○	○	○	○
Plana	●	●	●	○	○	●	●	●
Pulp	●	●	○	○	○	○	○	○
Rama	●	●	●	○	○	●	●	○

Divina Melange 2 (Kvadrat®) fabric

24 colours



120



170



180



220



260



280



421

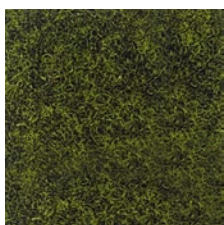

471



521



531



571



581



620



631

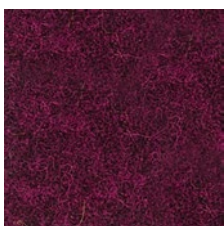

671

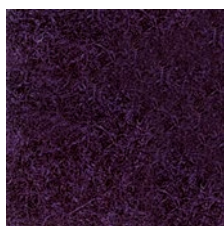

681



721

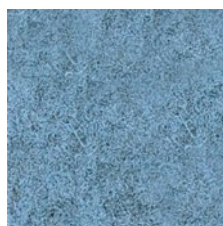

731



771



821



871

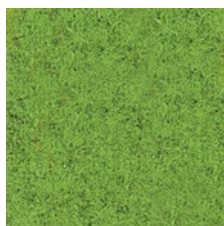

920



931

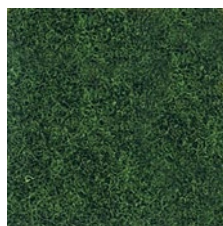

971

Design Finn Sködt

Composition 100% new wool

Abrasion app. 45.000 Martindale

Care 

kvadrat

Divina MD (Kvadrat®) fabric 27 colours

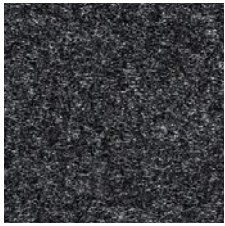

193



203



213



293



343



353



363



413



433



453



613

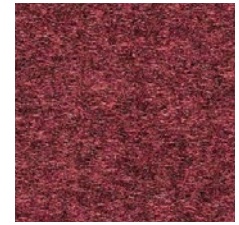

633



653



673



683



713



733

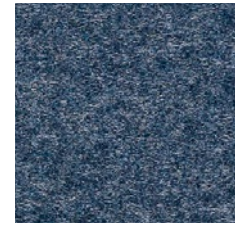

743



753

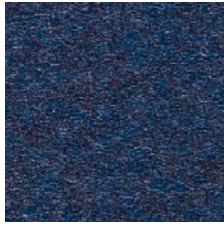

773



783



813



843



873



913



943



973

Design Finn Sködt

Composition 100% new wool

Abrasion app. 45.000 Martindale

Care



kvadrat

Hero (Kvadrat®) fabric 28 colours



Design Patricia Urquiola

Composition 96% new wool, 4% nylon

Abrasion app. 45.000 Martindale

Care 

kvadrat

Field 2 (Kvadrat®) fabric

30 colours



123

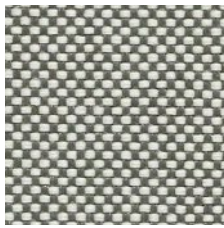

132

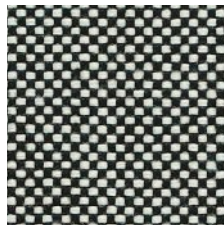

142

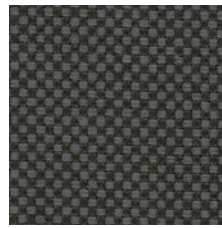

173

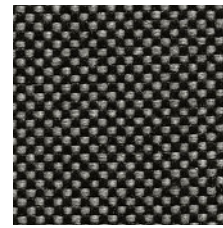

182



192



222



233

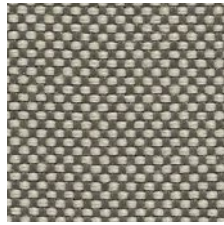

242

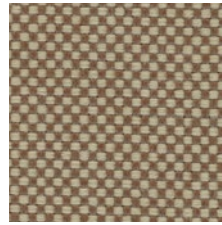

343

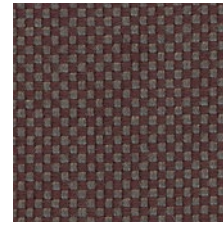

373

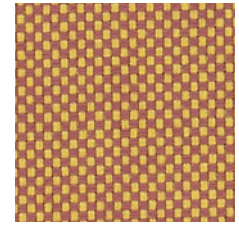

443

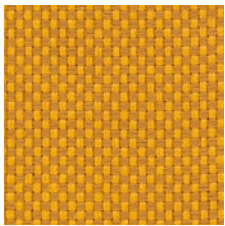

463

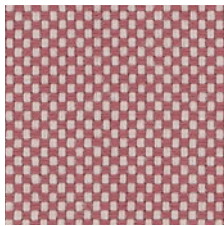

623

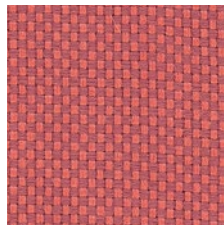

643

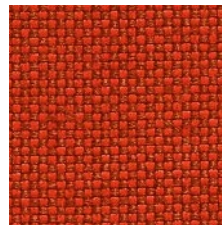

662

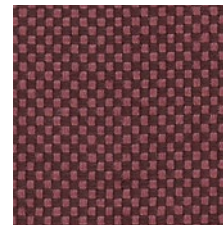

663

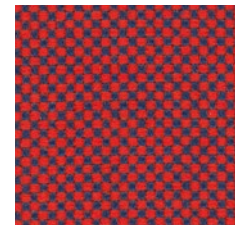

673

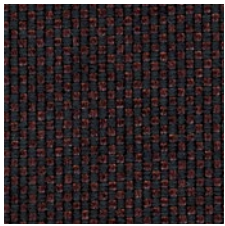

693

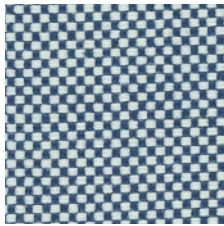

723

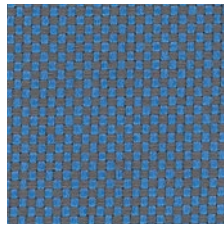

733



763

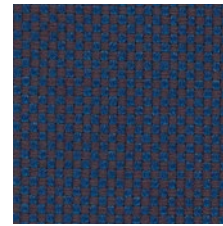

773

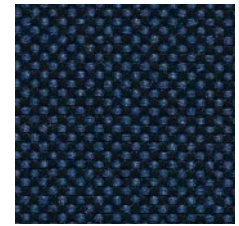

782



793

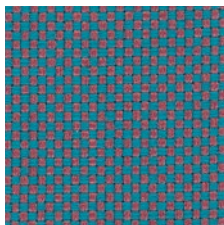

843



933



943

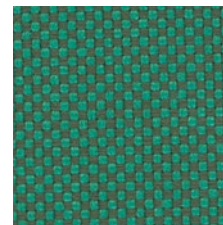

963

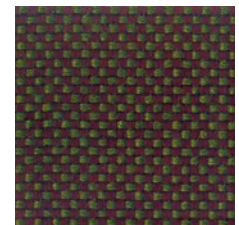

983

Design Alfredo Häberli

Composition 100% Trevira CS

Abrasion app. 100.000 Martindale

Care



kvadrat

Steelcut Trio 3 (Kvadrat®) fabric

54 colours



105



113

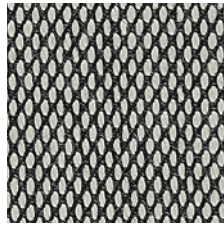

124

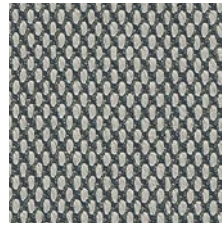

133

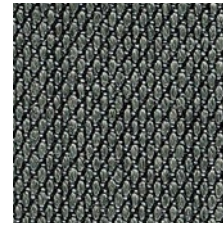

153

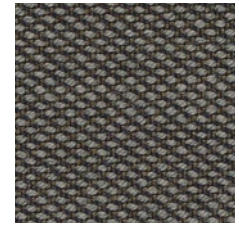

176



195

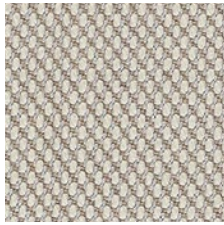

205

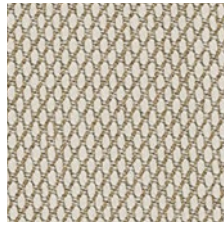

213

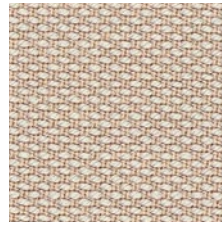

226

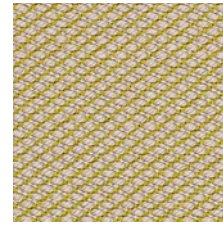

236

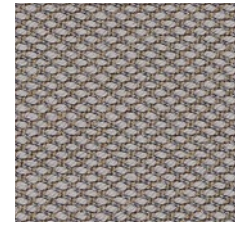

246



253

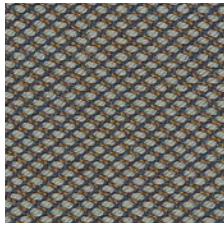

266

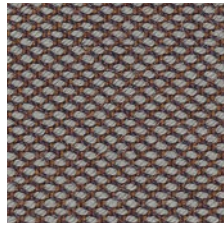

276

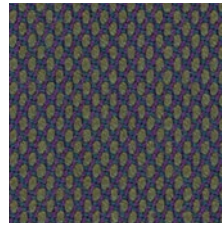

283

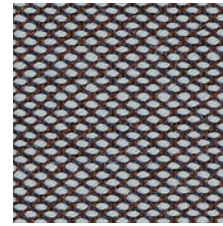

336

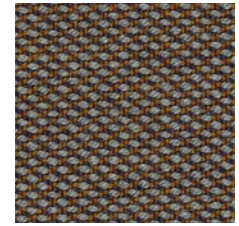

376

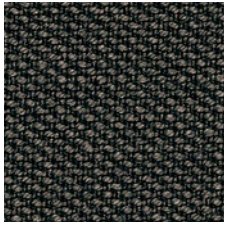

383

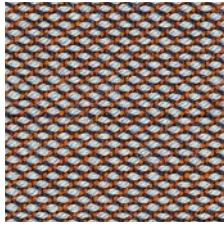

416

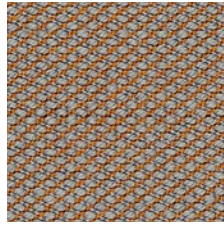

426

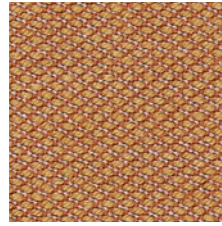

436

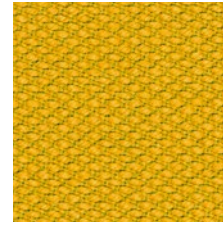

446

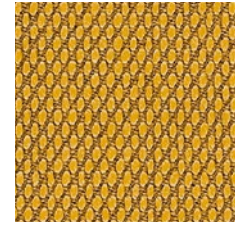

453



466

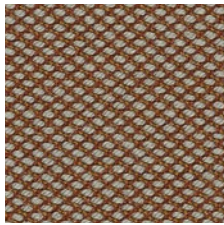

476

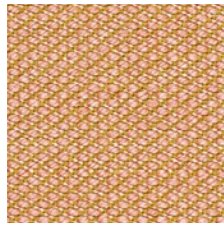

506

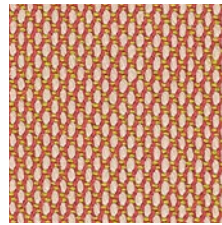

515

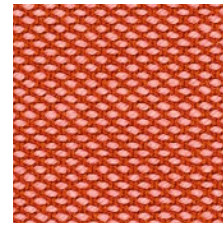

526



533



553

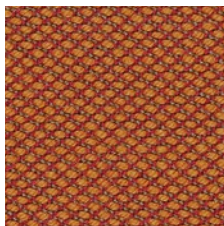

576

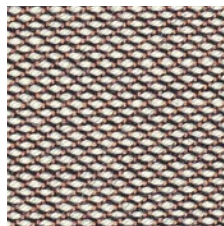

616

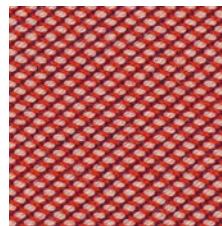

636



645



666



686

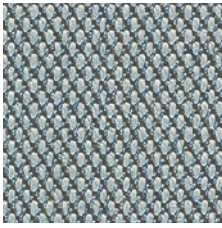

713

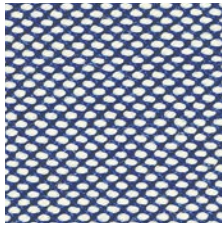

716

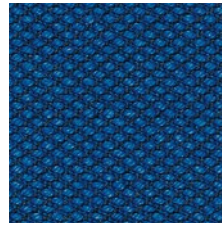

746

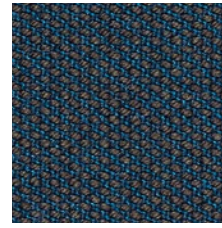

756

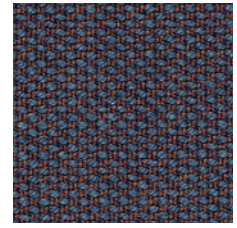

776



796

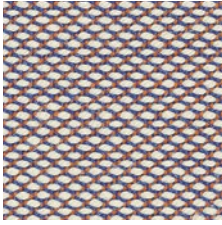

806

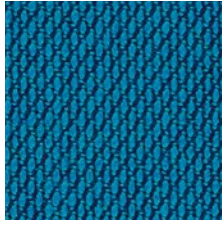

865



883



906

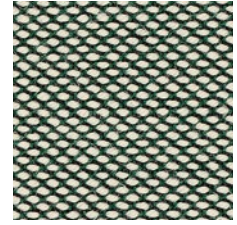

916

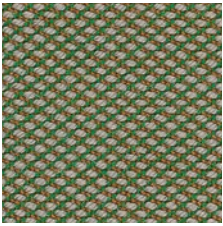

946

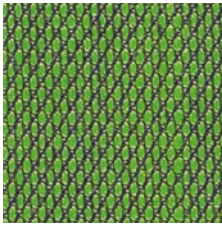

953

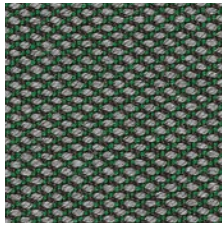

966

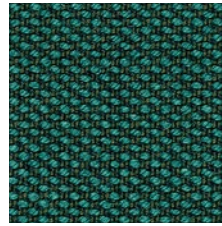

976

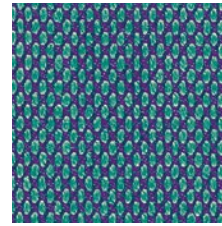

983

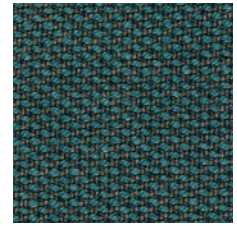

996

Design Frans Dijkmeijer and Giulio Ridolfo

Composition 90% new wool, worsted, 10% nylon

Abrasion app. 100.000 Martindale

Care 

kvadrat

Curmi (Torri Lana®) fabric 14 colours



620 030



620 031



620 036



620 037



620 040



620 043



620 044



620 045



620 046

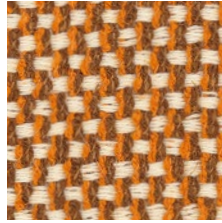

620 048

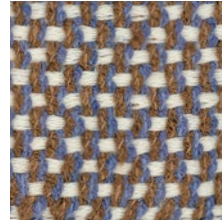

620 049



620 050



620 053



620 054

Composition 45% cotton, 20% viscose, 10% linen, 25% polyester

Abrasion app. 52.000 Martindale

Care



TORRI LANA

Regal (Erimiti®) velvet fabric 29 colours

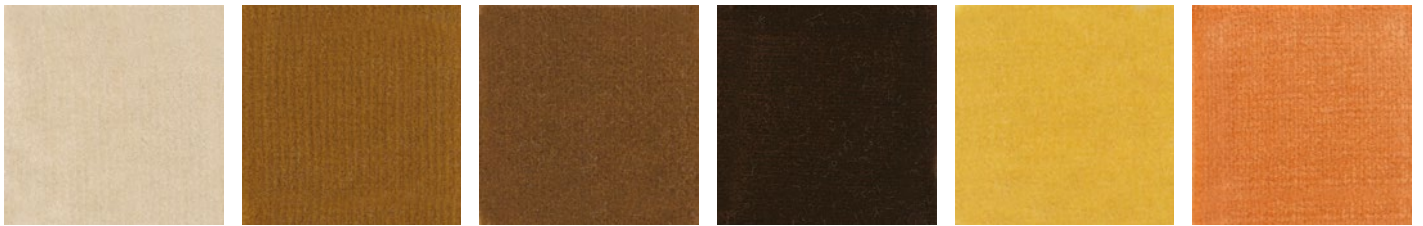

E001 E006 E008 E009 E010 E011



E012 E013 E015 E016 E020 E021

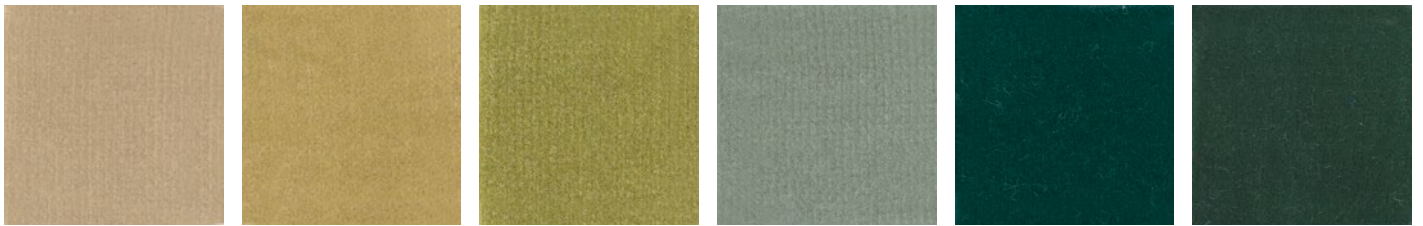

E030 E031 E032 E036 E037 E038

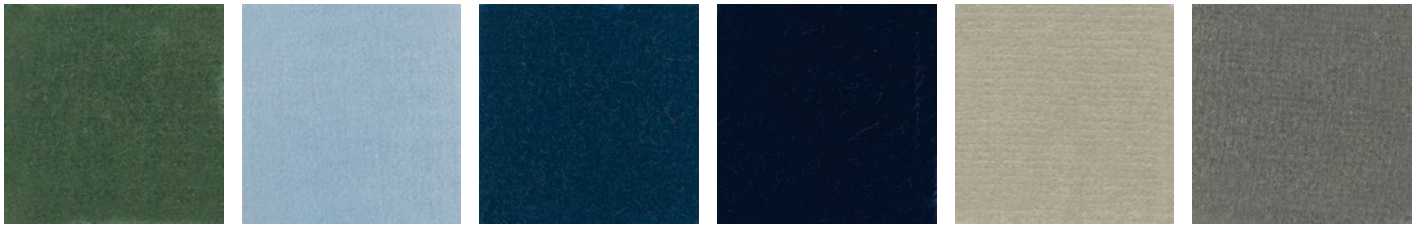

E039 E041 E042 E044 E045 E046

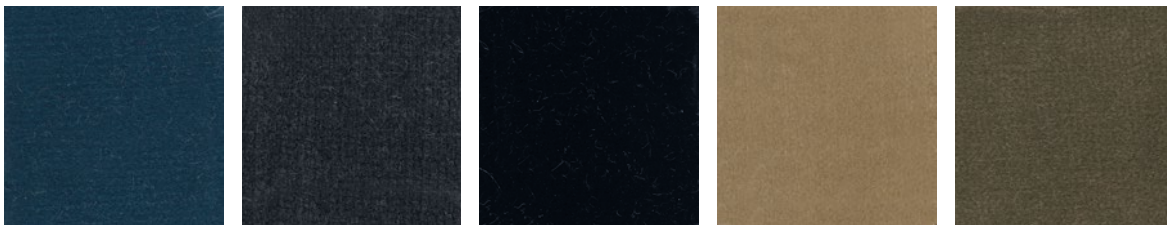

E047 E048 E049 E051 E052

Composition 100% cotton

Abrasion app. 100.000 Martindale

Care 

ERIMITI

Scuba (Kvadrat®) fabric

12 colours

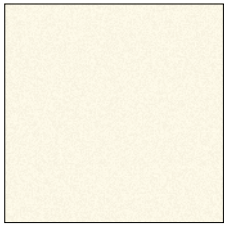

001

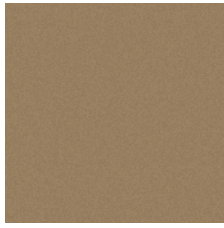

004

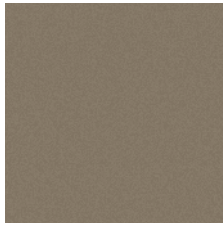

005

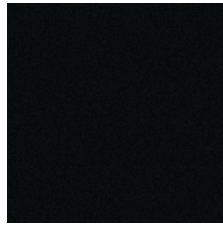

007

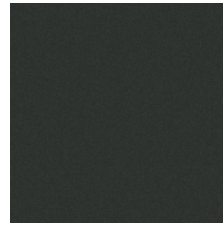

008

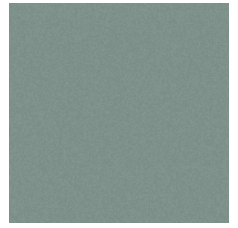

010

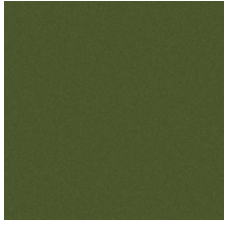

012

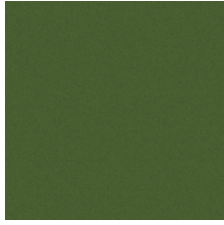

013

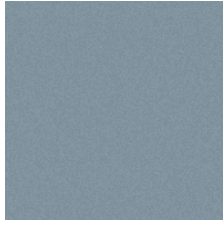

015

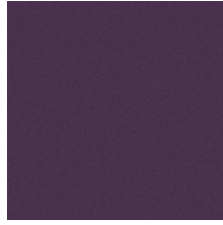

018

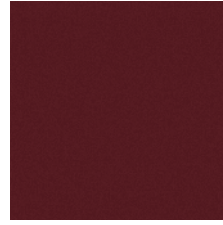

020

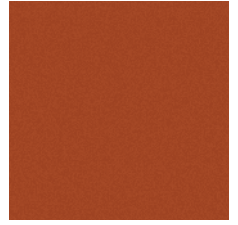

023

Design Maharam Design Studio

Composition 100% polyurethane (surface), 100% polyester (backing)

Abrasion app. 100.000 Martindale

Care



|m|h|r|a|m|
kvadrat

Extrema AU (Flukso®) synthetic leather

24 colours



150



250



350



450



550



650



750



850



950



1050



1150



1250



1350



1450



1550



1750



1850



1950



2050



2150



2250



2350



2450



2650

Composition 63% polyurethane, 29% cotton, 8% polyester

Abrasion app. 150.000 Martindale

Care



Elmosoft (Elmo®) semi-aniline leather
70 colours



0100

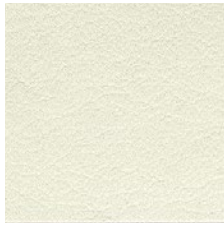

0019



00118



01003



01021



01037



01040



01061



01085



02085



02110



05007



05011



06001



07008



07029



07075

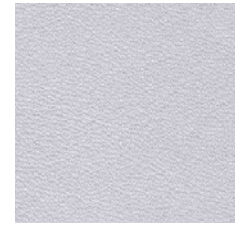

07080



08035



11033



11049



11073



12080



12105



13048



13053

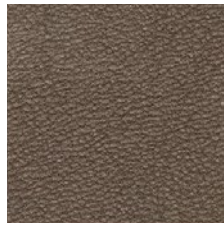

13064



13072

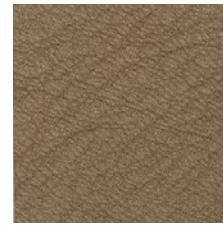

13087



16003



17027



22024



22030

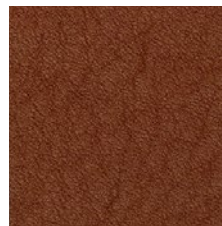

33001

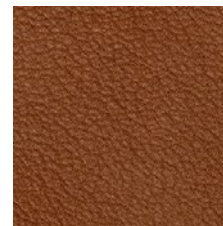

33004



35126



43054



43083



44005



44012

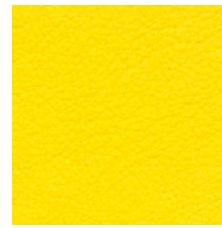

44026



45018



45050



45065

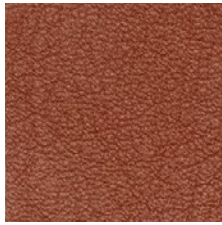

53032



54035



55002

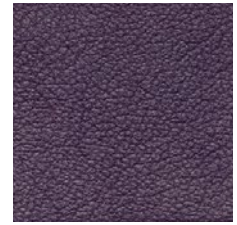

57349



71017



75010

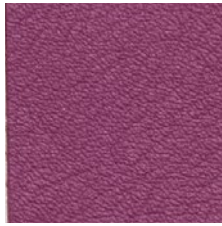

76025



77026



77030



77127



77158



78023



87088

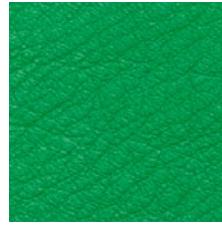

88005

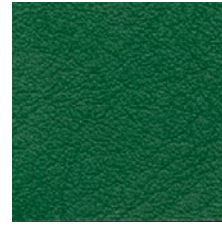

88020



88033



91102



93068



93099



93101



93129



95006



97038



98015



98047



99999

Coast (Elmo®) pigmented & printed leather 18 colours



00114

02061

08019

12097

18008

43041

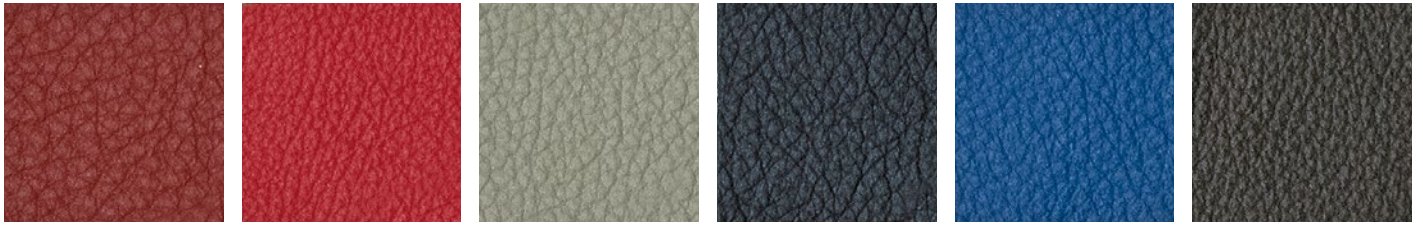

55032

55054

71010

77022

77025

91097

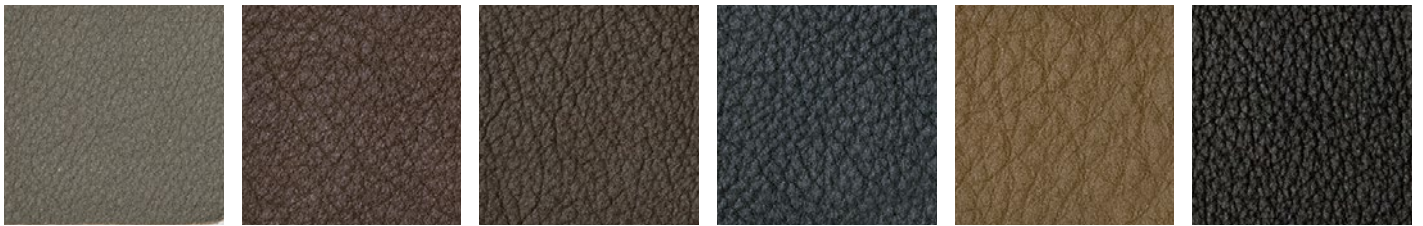

91100

93088

93090

97039

98016

99076

Cuoietto hide 12 colours

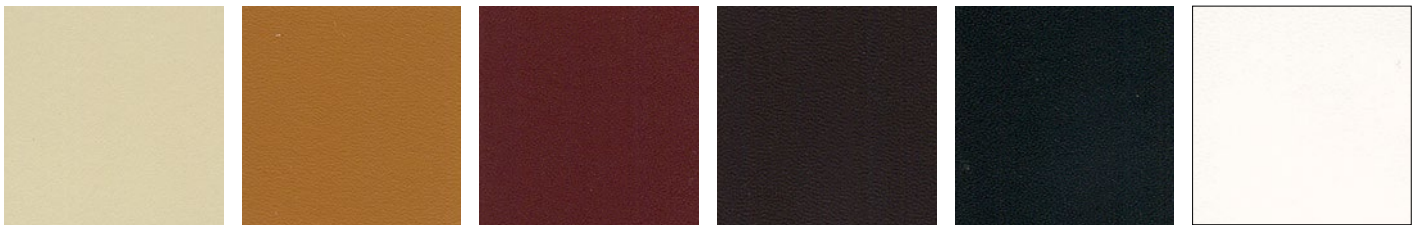

C1

C4

C7

C8

C10

C12

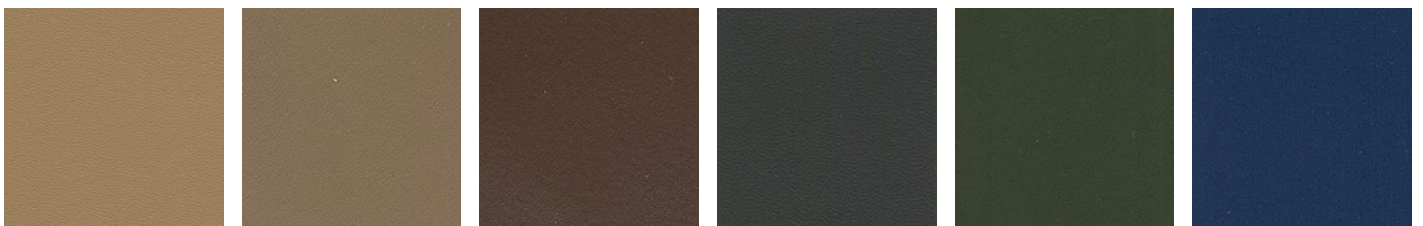

C31

C32

C33

C34

C35

C36

Elmotique (Elmo®) aniline leather

18 colours



03028



04010

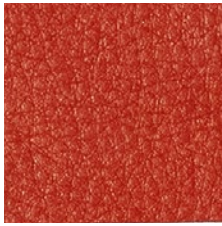

05025



11023



13033



17020



43024



43807



45011

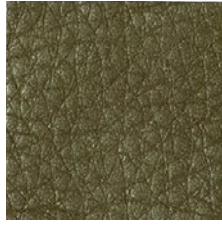

48027

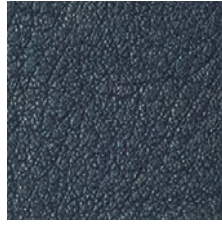

77875



91059



93021



93718



93957



95947



97026



99001

elmo®

Full-grain hide

2 colours



PF20 natural

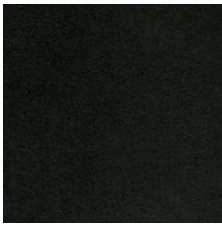

PF21 black

Kristalia srl

via A. Durante 28
33080 Prata (PN) Italy
T +39 0434 623678
F +39 0434 624901

info@kristalia.it
www.kristalia.it

Project:
Kristalia homemade

Photo:
Paolo Contratti /Contratticompany
Matteo Girola p.300, 302, 303, 306
Image courtesy Côté Maison p.134
Franco Moret p.299
Valentina Iaccarino (some still life photos)

Stylist:
Carla Bianchet
Vanda Gemino

Illustrations:
Francesca Rizzato p. A –T
Manuel Pablo Pace p. 304, 305

Copy:
Lisa Cadamuro
Chiara Alessi
Daniele Varelli

Translations:
Enjoy

Colour separation:
SIZ

Made and printed in Italy
Grafiche Filacorda with H-UV Technology

© Kristalia srl 2019
All rights reserved

January 2019 edition

Follow us on:



KRISTALIA®